



# PFBI COMBI

## Ref. 010334

### PUERTA DESLIZANTE SLIDING DOOR

Frigorífico COMBI de integración panelable  
Built-in refrigerator COMBI for overlay decor panel

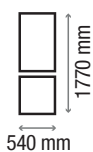

243 L  
Capacidad  
Capacity



UltraFresh  
Technology



Sistema Sliding Door  
Sliding Door System



180 L  
Natural  
Flow Cooling

63 L  
NO Frost  
Technology



#### Características / Features

Dimensiones producto (AlxAxAnxF)	Product size (HxWxD)	1770x540x545 mm
Total Volumen	Total Volume	243 L
Capacidad Frigorífico	Refrigerator Volume	180 L
Capacidad Congelador	Freezer Volume	63 L
Consumo de energía	Energy Consumption	218 kWh/año-year
Nivel de ruido acústico	Noise level	41 dBA
Iluminación interior LED	Interior LED Lighting	Sí / Yes
Clase Climática	Climate Class	Tropical
Peso máximo puerta panelable	Maximum weight of panel door	50 Kg

FUNCIONES: Modo vacaciones | Modo ECO | Modo Rápido | Modo Demo



Condensador Trasero = Laterales Fríos  
Rear Condenser Coil = Cold Sides

## PUERTA DESLIZANTE PFBI COMBI SLIDING DOOR Ref. 010334

Composición/ Composition: Side by Side

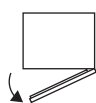

Apertura de serie Derecha  
Puerta reversible  
Standard opening Right  
Reversible door

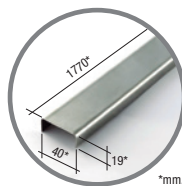

Opcional / Optional  
Ref. 010463  
Perfil de unión Inox  
Stainless Steel + connecting profile

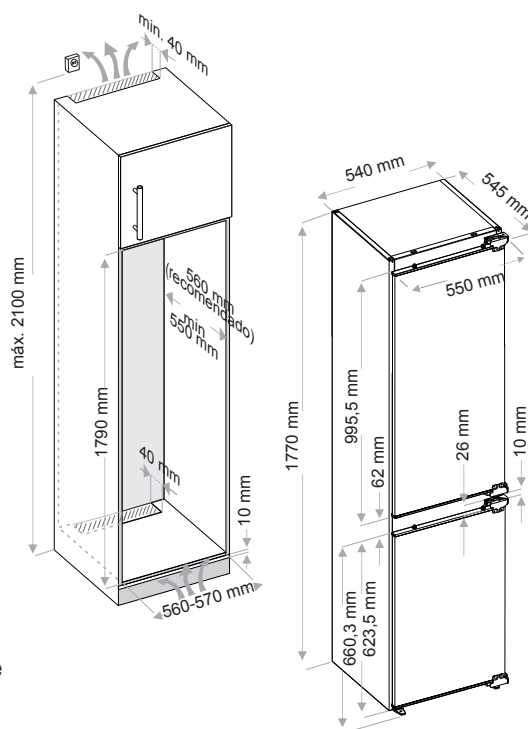

Medidas en / Dimensions in mm

PFBI COMBI + PFBI COMBI  
Ref. 010334 Ref. 010334