

Pando
integral*cooking*

The Global Kitchen **Partner**

COLLECTION 2025-2026

Pando integral**cooking**

The Global Kitchen **Partner**

CALIDAD CERTIFICADA
CERTIFIED QUALITY



(*) El uso de la certificación y de la marca es exclusivo para los modelos marcados con este símbolo en su etiqueta identificativa.
The use of the certification and the brand is exclusive for the models marked with this symbol on their identification tag.



**SHOWROOM
MADRID**
+34 619 550 549
pandomadrid@pando.es



**SHOWROOM
BARCELONA**
+34 93 757 94 11
com.pando@pando.es

¡BIENVENIDO AL MUNDO PANDO!

Pando Integral Cooking se posiciona como un referente mundial en diseño y fabricación de aparatos de cocina. Nuestra estrategia de internacionalización se ha fortalecido año tras año, logrando presencia en diversos mercados globales. Contamos con dos exclusivos showrooms en Madrid y Barcelona, donde ofrecemos una amplia selección de productos que abarcan nuestras siete innovadoras gamas. *Pando* es sinónimo de vanguardia, calidad y compromiso, llevando la excelencia española a cada rincón del mundo y transformando la experiencia culinaria de nuestros clientes.

¡WELCOME TO THE WORLD OF PANDO!

Pando Integral Cooking is a leading player in the world of design, sales and manufacturing of premium kitchen home appliances. The internationalisation of Pando, as well as its partner network and customer base have grown rapidly over the last decade, and with its unique products Pando is today serving high end customers not only in Europe, but also in various other countries around the world. We have two exclusive own Pando showrooms in Madrid and in Barcelona, where we present a wide selection of large premium kitchen appliances of our seven product groups.



Pando
5 AÑOS
GARANTÍA

FIABILIDAD Y GARANTÍA
RELIABILITY AND GUARANTEE

Pando
10 AÑOS
GARANTÍA

Para equipación de 5 o más productos por unidad de cocina.
EXCLUSIVO PARA ESPAÑA, PORTUGAL Y ANDORRA

For equipment of 5 or more products per kitchen unit.
EXCLUSIVE FOR SPAIN, PORTUGAL AND ANDORRA



Bajo registro en la web

Para los motores de campana:
V.1050 ECO, V.1130 ECO, V.1250 ECO, V.1550 ECO y V.2450 ECO.
Para motores de Lavadoras y Secadoras

For Cookers Hoods engines:
V.1050 ECO, V.1130 ECO, V.1250 ECO, V.1550 ECO and V.2450 ECO.
For Washing machine and Dryer motors



Bajo registro en la web



360° Kitchen Solutions



Campanas Decorativas
Decorative
Cooker hoods

p.36



Hornos & Microondas
Ovens
& Microwaves

p.170



Placas de
Inducción
Induction
hobs

p.216

Placas de
Gas
Gas
hobs

p.238



**Lavavajillas
integrables**
**Dishwashers
integrated**

p.244



**Lavadoras
& Secadoras**
**Washing machines
& Dryers**

p.258



**Frigoríficos
& Drink cooling center**
**Refrigerators
& Drink cooler**

p.270



Vinotecas
Wine Coolers

p.302



WELCOME TO THE FUTURE OF THE KITCHEN!

“The Global Kitchen Partner” concept at **Pando** is dedicated to strengthening the relationship with all specialists in the sector: from shops and studios to kitchen furniture manufacturers, interior designers, decorators and architects, offering integrated support and innovative solutions that adapt to the unique needs of each professional. With a wide range of products covering seven different lines, we have established ourselves as the best partner in the development of kitchen projects.

Imagine a space where every element is aligned with our customer's vision. Each of our ranges has been designed to provide 360° solutions, ensuring you find the perfect option to bring your ideas to life.

At **Pando**, we don't just make kitchen products; we create experiences.

CREATE YOUR COMFORT SPACE

EXPERIENCE | QUALITY DESIGN | INNOVATION

After more than 45 years of dedication and passion, we are pleased to present our new product catalogue, a true testament to our commitment to excellence and innovation. At **Pando**, every launch is more than just an event; it is an exciting challenge that we embrace with enthusiasm. We know there is always room to improve and surprise our valued customers, which is why every product we create is a masterpiece that combines the experience accumulated over the years with cutting-edge design and state-of-the-art technology.

Quality, design and innovation are part of our DNA. We are proud to maintain a strong commitment to our origins, honouring tradition while looking to the future.



¡BIENVENIDO AL FUTURO DE LA COCINA!

Bajo el concepto de "The Global Kitchen Partner", en **Pando** nos dedicamos a fortalecer la relación con todos los especialistas del sector: desde tiendas y estudios hasta fabricantes de muebles de cocina, interioristas, decoradores y arquitectos, ofreciendo un apoyo integral y soluciones innovadoras que se adaptan a las necesidades únicas de cada profesional. Con una amplia gama de productos que abarca siete líneas distintas, nos consolidamos como el mejor socio en el desarrollo de proyectos de cocina.

Imagina un espacio donde cada elemento se alinea con la visión de nuestro cliente. Cada una de nuestras gamas ha sido diseñada para proporcionar soluciones 360°, garantizando que encuentre la opción perfecta para hacer realidad sus ideas.

En **Pando**, no solo fabricamos productos de cocina; creamos experiencias.

CREA TU ESPACIO DE CONFORT

EXPERIENCIA | CALIDAD DISEÑO | INNOVACIÓN

Después de más de 45 años de dedicación y pasión, nos complace presentar nuestro nuevo catálogo de productos, un verdadero testimonio de nuestro compromiso con la excelencia y la innovación. En **Pando**, cada lanzamiento es más que un simple evento; es un emocionante reto que abrazamos con entusiasmo. Sabemos que siempre hay espacio para superarnos y sorprender a nuestros valiosos clientes, y es por eso que cada producto que creamos es una obra maestra que combina la experiencia acumulada a lo largo de los años con un diseño vanguardista y la más alta tecnología.

La calidad, el diseño y la innovación son parte de nuestro ADN. Nos enorgullece mantener un fuerte compromiso con nuestras raíces, honrando la tradición mientras miramos hacia el futuro.

CREA Y DIMENSIONA TU IDEA

FABRICACIÓN PROPIA CAMPANAS EXTRACTORAS A MEDIDA DISEÑOS DE VANGUARDIA

Solo un verdadero artesano puede infundir en cada pieza una sensibilidad especial, lo que permite que cada campana no solo sea un elemento funcional, sino también una expresión estética. En un mercado donde la uniformidad y la linealidad predominan, **Pando** marca la diferencia con productos que combinan un atractivo diseño con la capacidad de aportar confort, luz y color a cualquier espacio.

Cada campana de **Pando** es el resultado de un meticuloso proceso de fabricación que prioriza la calidad y la creatividad, asegurando que cada cliente encuentre en sus productos una solución que eleva su entorno.

CREATE AND SIZE YOUR IDEA

OWN FABRICATION BESPOKE COOKER HOODS VANGUARD DESIGNS

Only real craftsmen can infuse each piece with a special sensitivity, allowing each hood to be not only a functional element, but also an aesthetic expression. In a market where uniformity and linearity predominate, **Pando** sets itself apart with products that combine attractive design with the ability to bring comfort, light and colour to any space.

Each **Pando** hood is the result of a meticulous manufacturing process that prioritises quality and creativity, ensuring that each customer finds in its products a solution that elevates their environment.

CREA, PERSONALIZA Y DA COLOR A TUS DISEÑOS

NUEVOS MATERIALES NUEVOS COLORES NUEVOS DISEÑOS

Pando ofrece una propuesta excepcional en la creación y personalización de campanas, adaptándose a las necesidades específicas de cada proyecto de cocina. Cada campana se convierte en una expresión personal, permitiendo a los clientes elegir entre una amplia gama de “colores a la carta” y texturas que armonizan perfectamente con el entorno de su cocina.

La colección de **Pando** destaca por su uso de materiales nobles, como el acero inoxidable de primera calidad, que se puede combinar con acabados en inox cobre o inox dorado. Esta versatilidad permite a los usuarios acercarse tanto a lo más innovador como a lo vintage, creando un ambiente único y distintivo.

CREATE & CUSTOMIZE YOUR DESIGNS

NEW MATERIALS NEW COLOURS NEW DESIGNS

Pando offers an exceptional approach to the creation and customisation of hoods, adapting to the specific needs of each kitchen project. Each hood becomes a personal expression, allowing customers to choose a ‘bespoke’ colour and textures that harmonise perfectly with their kitchen environment.

The **Pando** collection stands out for its use of noble materials, such as premium stainless steel, which can be combined with copper or brass/gold finishes. This versatility allows users to approach both the most innovative and the vintage, creating a unique and distinctive atmosphere.



Acabados
DEKTON®

Blanco RAL 9003
White

Negro SATINADO
Black SATIN

Negro mate
RAL 9005
Black

Inox cobre
Stainless Steel
copper

Inox oro
Stainless Steel
gold



PANDO: RESPONSABILIDAD ECOLÓGICA

**ECO-EFICIENCIA | SOSTENIBILIDAD*
CUIDADO DEL ENTORNO**

**SISTEMAS ECO RESPONSABLES
PENSADOS PARA EL MÍNIMO CONSUMO,
Y LAS MÁXIMAS PRESTACIONES.**

Pando reafirma su compromiso con sus clientes y el medio ambiente a través de nuevas líneas de productos con altas prestaciones y mínimo consumo. Cada uno de sus productos ha sido meticulosamente diseñado con un enfoque en la eficiencia energética, lo que permite a los usuarios disfrutar de un rendimiento óptimo mientras reducen su consumo de energía.

En *Pando*, la innovación va más allá de la tecnología; se trata de responsabilidad. Por ello, se ha implementado medidas que aseguran que sus productos sean no solo eficientes, sino también respetuosos con el entorno. En *Pando Integral Cooking* promovemos la innovación y la sostenibilidad como modelo para un mundo más verde, un principio que mantenemos firmemente.

PANDO: ECOLOGICAL RESPONSIBILITY

**ECO-EFFICIENCY | SUSTAINABILITY
ENVIRONMENTAL FRIENDLINESS**

**SYSTEMS TO REDUCE
ENERGY CONSUMPTION AND
TO MAXIMIZE PERFORMANCE**

Pando reaffirms its commitment to its customers and the environment through new lines of high-performance, energy-efficient systems. Each of its products has been meticulously designed with a focus on energy efficiency, allowing users to enjoy optimum performance while reducing their energy consumption.

At *Pando*, innovation is about more than technology; it is about responsibility. That is why it has implemented measures to ensure that its products are not only efficient, but also environmentally friendly. At *Pando Integral Cooking* we promote innovation and sustainability as a model for a greener world, a principle that we firmly uphold.

REDUCCIÓN DE LA HUELLA DE CARBONO

**COMPENSACIÓN TOTAL POR SEGUNDO AÑO
CONSECUTIVO DE NUESTRA HUELLA DE CARBONO**

Pando está plenamente comprometido con la sostenibilidad y las acciones para reducir los efectos del cambio climático. En 2023 y 2024, compensamos completamente la huella de carbono (alcances 1 y 2) mediante nuestra colaboración y apoyo al proyecto de repoblación forestal de la CMVMC de Silvoso ubicado en el Municipio de Ponte de Caldelas de Pontevedra (Galicia). Este gran proyecto ambiental contribuye a la mitigación del cambio climático mediante la restauración de bosques, alineándose de esta manera con los objetivos globales de sostenibilidad.

Como reconocimiento a sus esfuerzos, *Pando* ha obtenido, el sello oficial del Ministerio para la Transición Ecológica de España, destacando así su compromiso con la reducción y compensación del impacto ambiental generado por su actividad industrial y comercial durante estos 2 años. *Pando* es una de las pocas empresas con actividad industrial en España que ha logrado no solo “calcular” su impacto ambiental (=“huella de carbono”), sino que también “compensarla en su totalidad”.

REDUCTION OF THE GLOBAL CARBON FOOTPRINT

**PANDO FULLY OFFSETS ITS CARBON FOOTPRINT
FOR THE SECOND YEAR IN A ROW**

Pando is fully committed to sustainability and all activities to reduce the effects of climate change. In 2023 and 2024, we completely offset its carbon footprint (scopes 1 and 2) through our collaboration and support for the Silvoso CMVMC reforestation project located in the municipality of Ponte de Caldelas in Pontevedra (Galicia). This major environmental project contributes to mitigating climate change through forest restoration, thus aligning with global sustainability goals.

In recognition of its efforts, *Pando* has obtained the official seal of approval from the Spanish Ministry for Ecological Transition, thus highlighting its commitment to reducing and offsetting the environmental impact generated by its industrial and commercial activity over the last two years. *Pando* is one of the few companies with industrial activity in Spain that has managed not only to ‘calculate’ its environmental impact (= ‘carbon footprint’), but also to ‘compensate for it in its entirety’.



+info

CO₂



ECO-EFICIENCIA



SOSTENIBILIDAD



CUIDADO DEL ENTORNO



MARKETPLACE DE DONACIÓN DESTINADO A PROYECTOS DE ECONOMÍA CIRCULAR



ISO 14001 SISTEMAS DE GESTIÓN DEL MEDIOAMBIENTE (SGA)



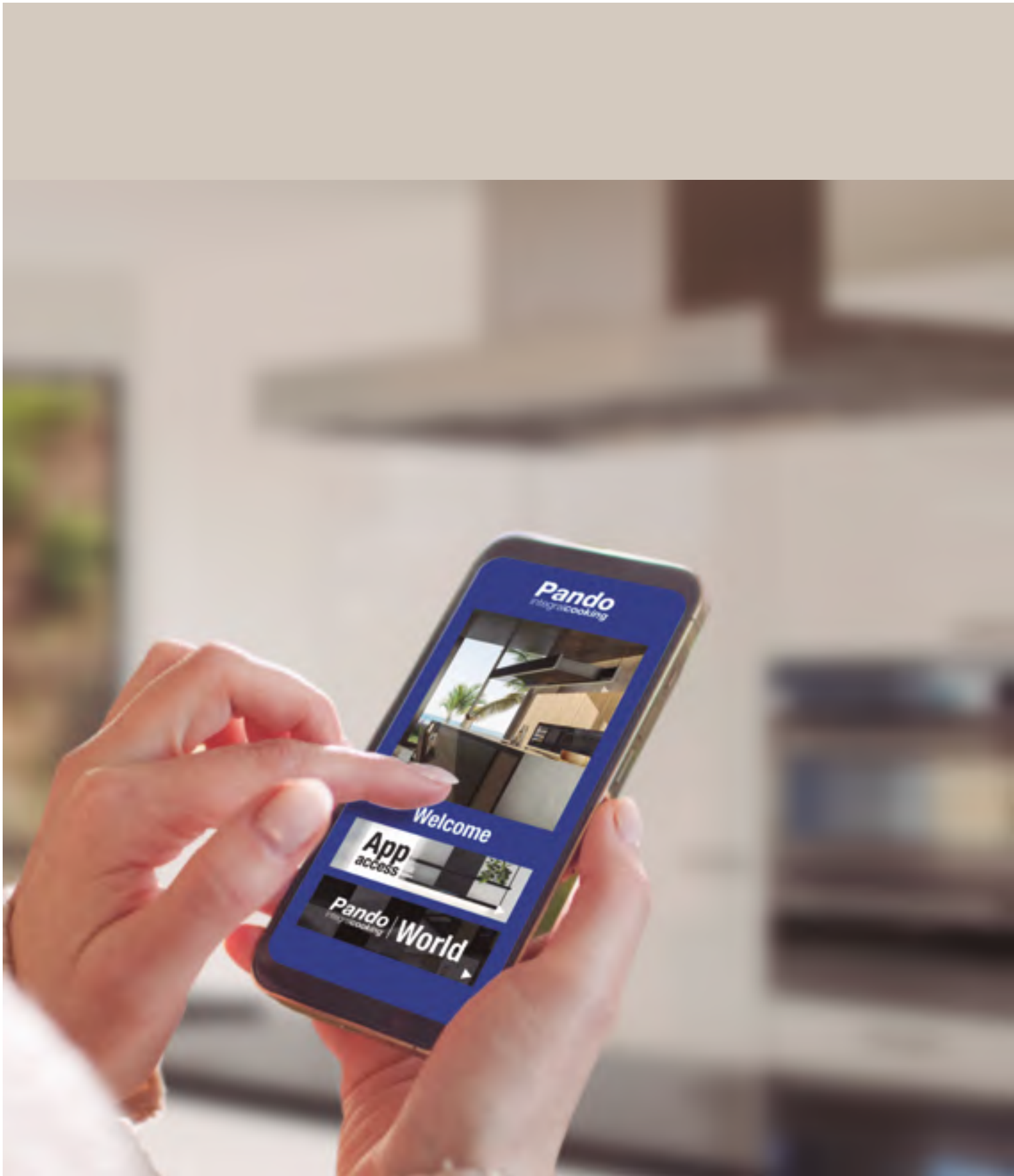



**PRODUCTOS
DISEÑADOS Y
OPTIMIZADOS
PARA GARANTIZAR
EL MÁXIMO
RENDIMIENTO**

**PRODUCTS
DESIGNED AND
OPTIMIZED TO
ENSURE MAXIMUM
PERFORMANCE**

TECHNOLOGY

NUUESTRA
TECNOLOGÍA

OUR
TECHNOLOGY

OUTSIDE

1

ADAPTABILIDAD SOMOS FABRICANTES

La experiencia y "Know How" permiten elaborar productos a medida y específicos para el catálogo así como para proyectos especiales, donde se puede seleccionar: MATERIAL, FORMA, DIMENSIÓN y COLOR.

2

INNOVACIÓN *AirLink* by Pando

Sistema inteligente de interconexión entre campana y placa de inducción

3

ILUMINACIÓN SISTEMA PANDO LED

Todos los sistemas de luz son mediante LED de Alta Eficiencia. **Pando LED**: Control de intensidad y temperatura de color.

4

SISTEMAS DE CALIDAD DEL AIRE PARA EL BIENESTAR

Mantener un aire limpio en interiores es esencial para la salud. La filtración y purificación reducen contaminantes, y en la cocina, una campana extractora con filtros de alta eficiencia ayuda a eliminar olores, aceites y alérgenos, creando un ambiente más saludable.

5

CONFORT Y SILENCIO

En **Pando**, la tranquilidad y el bienestar del hogar son prioridades fundamentales. Un ambiente armonioso se logra no solo con un diseño atractivo, sino también con el cuidado del sonido en su entorno. Por ello, se han desarrollado motores para las campanas que cuentan con una reducción sonora de hasta un 20%.

ADAPTABILITY MADE TO ORDER

The experience and "Know How" allow the development of specific products for the catalog and for special projects, where it is possible to choose from: MATERIAL, SHAPE, SIZES and FINISH.

INNOVATION *AirLink* by Pando

Smart intercom system between Ceiling hood and our cooktops

LIGHTING PANDO LED SYSTEM

All lighting systems are based on high efficiency LEDs **Pando LED**: adjusting brightness and colour temperature.

AIR QUALITY SYSTEMS FOR WELL-BEING

Maintaining clean air indoors is essential for health. Filtration and purification reduce pollutants, and in the kitchen, a cooker hood with high-efficiency filters helps to eliminate odours, oils and allergens, creating a healthier environment.

COMFORT & SILENCE

At **Pando**, quietness and well-being in the home are top priorities. A harmonious atmosphere is achieved not only with an attractive design, but also by taking care of the sound in your environment. For this reason, we have developed motors for the hoods that have a sound reduction of up to 20%.

**ALTA TECNOLOGÍA
PARA DISFRUTAR
UNA EXPERIENCIA
CULINARIA EXCEPCIONAL**

**LATEST TECHNOLOGIES
TO ENJOY AN
EXCEPTIONAL
COOKING EXPERIENCE**



NUUESTRA
TECNOLOGÍA

OUR
TECHNOLOGY

SISTEMAS DE CONTROL CONTROL PANELS



Conectividad total que permite gestionar su campana desde el móvil a través de la **Pando Wifi** o mediante Google Home y Alexa. Gracias a la aplicación, los usuarios pueden controlar su motor y regular la iluminación con solo unos toques. La integración con asistentes de voz como Google Home y Alexa permite un manejo aún más eficiente y amigable. Además, **Pando** proporciona información técnica detallada y facilita el monitoreo del consumo de energía, asegurando que cada aspecto esté bajo control.

Full connectivity that allows you to manage your bell from your mobile phone via the **Pando Wifi** or via Google Home and Alexa. Thanks to the app, users can control their motor and dim the lighting with just a few taps. Integration with voice assistants such as Google Home and Alexa makes operation even more efficient and user-friendly. In addition, **Pando** provides detailed technical information and facilitates the monitoring of energy consumption, ensuring that every aspect is under control.

BOTONERAS ELECTRÓNICAS Y TOUCH CONTROL ELECTRONIC BUTTON PANELS AND TOUCH CONTROL



Touch



Elect.

Las botoneras de control que incorporan nuestros equipos, en función de la dotación de cada modelo, para la selección de la velocidad, iluminación etc. Con apagado automático de seguridad.

The control panels featured on our units, depending on the characteristics of each model, for the selection of speed, lighting, etc. It includes an automatic safety stop.



BOTONERA DE ENCASTRE A PARED BUTTON PANEL FOR WALL INSET MOUNTING

Ahora todas las campanas de techo pueden incorporar de forma opcional, una botonera de control de la campana encastrada a pared.

All ceiling-mounted models can now benefit from a new optional feature: a control button panel for the hood set into the wall.



MANDO A DISTANCIA REMOTE TOUCH CONTROL



Touch

Sistema de control remoto de los mandos de la campana. Se incorpora de serie en todos los modelos de Techo y es opcional en muchos otros equipos. Con apagado automático de seguridad.

Remote control system for the hood functions. This is standard for all Ceiling models and optional for many others. It includes an automatic safety stop.



FUNCIONALIDAD LAST-TIME LAST-TIME FUNCTION

Last
TIME

Sistema de apagado automático, que incorporan una amplia gama de modelos. Al pulsar esta función, la campana se detiene automáticamente pasado unos minutos después de su uso, para garantizar la total extracción de los humos del conducto de salida.

An automatic stop system available on a wide range of models. When this function is activated the hood stops automatically a few minutes after it is used, to ensure that any remaining fume is also extracted.

NUESTRA
TECNOLOGÍA

OUR
TECHNOLOGY

2



AirLink

SISTEMA DE CONTROL INTELIGENTE COMBINANDO FUNCIONES DE CAMPANA Y PLACA DE INDUCCIÓN.

- La luz se enciende automáticamente al conectar la placa.
- El motor enciende automáticamente cuando se inicia el ciclo de cocción en cualquier zona de la placa.
- El motor se enciende o apaga dependiendo del nivel de potencia del motor, ajustándolo en función del uso de la placa de cocción.
- La Campana y la Placa deben sincronizarse, por lo que deben ser totalmente compatibles. (Consulte qué Campanas y Placas permiten utilizar el sistema AirLink).

SMART CONTROL SYSTEM COMBINING HOOD AND INDUCTION COOKTOP FUNCTIONS.

- Light turns on automatically when hob is connected.
- Motor starts automatically when cooking cycle begins on any part of the hob.
- Motor powers up or down, depending on the power level of the motor, adjusted according to the use of the hob.
- The hood and the hob must be synchronised, so they must be fully compatible (Please check what hoods and hobs are compatible with this system).

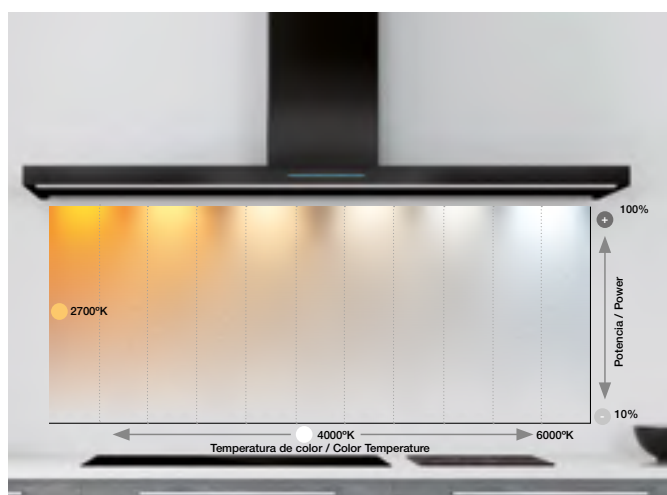

El sistema **Pando LED** está consolidado como la referencia en iluminación de última generación, ofreciendo soluciones versátiles para crear una variedad de ambientes. Su principal ventaja es el ahorro energético, permitiendo regular tanto la intensidad como el color de la luz según las necesidades de cada espacio. Desde la luz suave de las velas hasta la intensidad del sol, **Pando LED** ofrece diversas opciones. Además, su tecnología asegura un rendimiento eficiente, optimizando la energía que recibe la campana. Esto no solo mejora la personalización de la iluminación, sino que también reduce el consumo energético.

Pando promueve un estilo de vida más sostenible y respetuoso con el medio ambiente al transformar la manera en que iluminamos nuestros espacios.

3

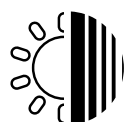

**Pando
LED**

SISTEMA DE PERSONALIZACIÓN DE LA ILUMINACIÓN LED

CUSTOMIZED LED LIGHTING SYSTEM

The **Pando LED** system is an established benchmark in state-of-the-art lighting, offering versatile solutions to create a wide variety of atmospheres. Its main advantage is energy saving, allowing both the intensity and colour of the light to be regulated according to the needs of each space. From soft candlelight to the intensity of the sun, **Pando LED** offers a range of options. In addition, its technology ensures efficient performance, optimising the energy received by the hood. This not only improves lighting customisation, but also reduces the energy use.

Pando promotes a more sustainable and environmentally friendly lifestyle by transforming the way we light our spaces.

INSIDE

1 SOLUCIONES DE AIRE LIMPIO SISTEMAS DE RECIRCULACIÓN

Diseñamos y fabricamos sistemas de extracción de alto rendimiento con un consumo energético mínimo. Las campanas de Pando Integral Cooking cuentan con una amplia gama de sistemas de filtración, incluyendo el innovador sistema integrado Eco-Plasma by Pando, los filtros de carbón activado lavables y reactivables de alta eficiencia, filtros de carbón activado cerámico reactivables y los avanzados filtros Nanotec, desarrollados para ofrecer la máxima absorción de partículas y olores.

2 EFICIENCIA SEC System y SEC System PLUS de Pando

Nuevos sistemas que permiten máxima eficacia, mínimo consumo y máxima insonorización.

3 SISTEMAS DE FILTROS MÁXIMA EFICIENCIA DE EXTRACCIÓN

Diferentes tipos de filtros garantizan la máxima eficacia en la captación de partículas y aceites residuales de cocción. Filtros de aluminio, acero inoxidable, de laberinto, hasta inoxidables de nueve capas, que ofrecen mayor absorción, más velocidad de aspiración, reducción del sonido entre otras características.

4 FACILIDAD DE INSTALACIÓN Y SISTEMAS DE MONTAJE

Sistemas de fácil montaje para todos los tipos de campanas: techo, pared o integración. Con los sistemas ADS QUICK FIX, I-FIX, SEC PLUS, entre otros.

5 VERSATILIDAD MOTORIZACIONES E INSTALACIONES

Compuesta por gran variedad de motores, además de los solicitados para proyectos especiales, ofreciendo una extensa gama de opciones de instalación.

CLEAN AIR SOLUTIONS RECIRCULATION SYSTEMS

We design and manufacture high-performance extraction systems with minimal energy consumption. Pando Integral Cooking range hoods feature a wide selection of filtration systems, including the innovative Eco-Plasma by Pando integrated system, high-efficiency washable and rechargeable activated carbon filters, rechargeable ceramic activated carbon filters, and advanced Nanotec filters, designed for maximum absorption of particles and odors.

EFFICIENCY SEC System and SEC System PLUS by Pando

New systems allowing maximum efficiency, minimum energy consumption and maximum noise reduction.

FILTER SYSTEMS HIGHEST EXTRACTION EFFICIENCY

Various types of filters guarantee maximum effectiveness in capturing cooking residues such as particles and oils. Options include aluminum filters, stainless steel filters, labyrinth filters, and even nine-layer stainless steel filters, offering greater absorption, increased suction speed, and noise reduction, among other benefits.

EASY INSTALLATION ASSEMBLING SYSTEMS

Easy-to-mount systems for all types of range hoods: ceiling, wall-mounted, or built-in. Featuring ADS QUICK FIX, I-FIX, SEC PLUS, and other advanced mounting solutions.

VERSATILITY MOTORIZATION & INSTALLATION OPTIONS

A wide variety of motors, including custom solutions for special projects, offering an extensive range of installation possibilities.

DESARROLLAMOS
SISTEMAS DE EXTRACCIÓN DE
ALTO RENDIMIENTO, CON EL
MÍNIMO CONSUMO ENERGÉTICO

WE DEVELOP
HIGH-PERFORMANCE
EXTRACTION SYSTEMS WITH
MINIMAL ENERGY CONSUMPTION

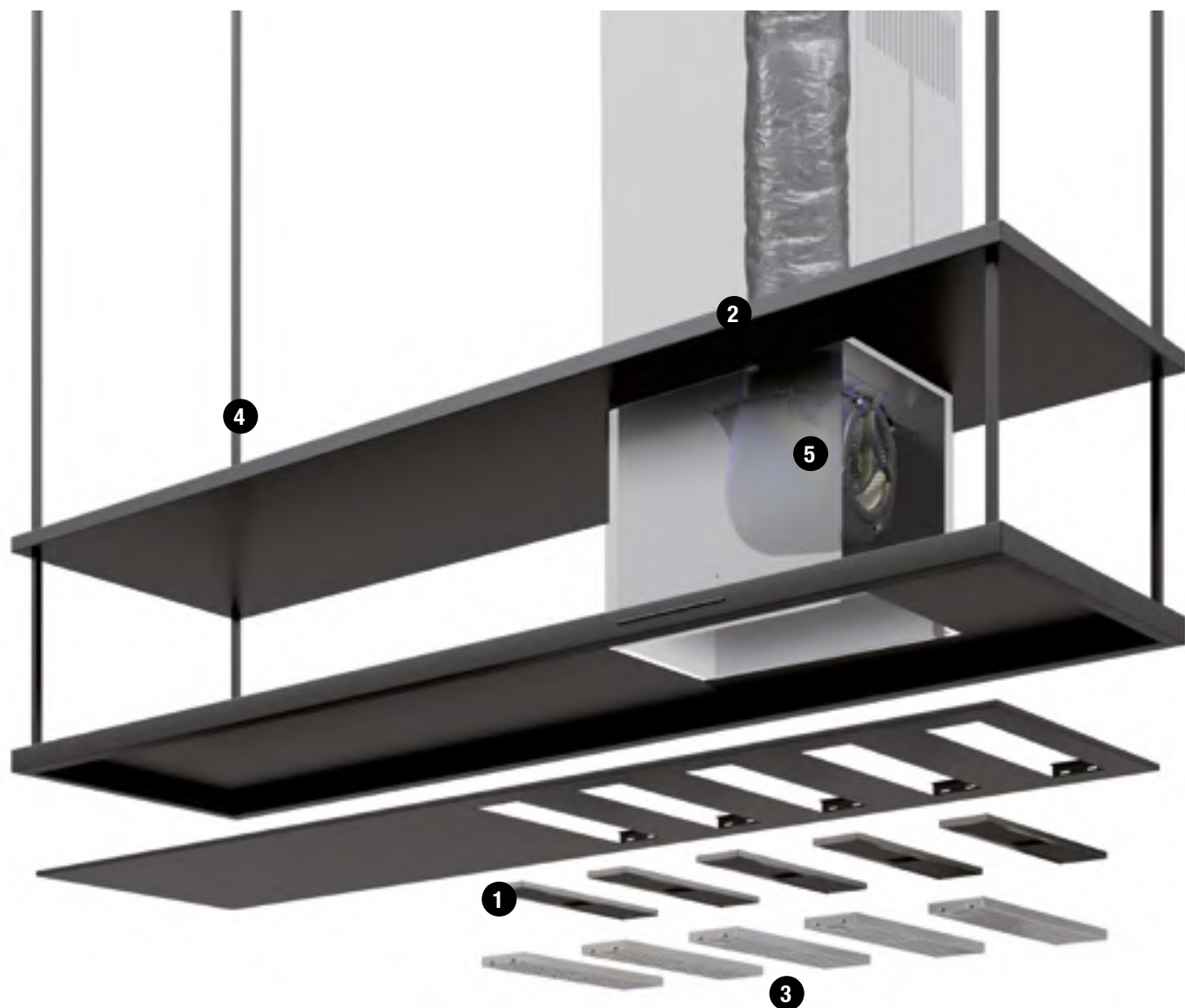

NUUESTRA
TECNOLOGÍA

OUR
TECHNOLOGY

SISTEMAS INTEGRADO | INTEGRATED SYSTEM

+ - **Eco-Plasma**

1 by Pando

DENSIDAD DE IONES EN CIUDADES Y EDIFICIOS <300 IONS/cm³
ION DENSITY IN BUILDINGS <300 IONS/cm³



Eco-Plasma by Pando es un SISTEMA INTEGRADO e híbrido de vanguardia, que elimina olores, mejora la calidad del aire y es totalmente respetuoso con el medio ambiente. Es un sistema “opcional” que puede integrarse casi en la totalidad de modelos de Campanas Pando. Su innovadora tecnología de plasma es un sistema capaz de desinfectar y esterilizar ambientes, proporcionando un hogar más saludable y libre de contaminantes.

MÁXIMA EFICIENCIA EN TODO EL HOGAR

A diferencia de otros sistemas, el Sistema Integrado Eco-Plasma by Pando no solo está diseñado para la cocina, sino que purifica perfectamente el aire de la estancia. Su avanzada tecnología de Ionización Bipolar por Plasma permite:

- Purificación del del aire, eliminando virus, bacterias y partículas alérgicas y nocivas.
- Neutralización de olores, proporcionando un ambiente fresco y limpio.
- Eliminación de contaminantes en superficies, mejorando la higiene del entorno.
- Reducción de polvo en suspensión, facilitando su eliminación.

INNOVACIÓN QUE RESPETA EL MEDIO AMBIENTE

Gracias a su integración dentro de la campana, Eco-Plasma by Pando ofrece una solución sostenible y energéticamente eficiente, sin generar residuos ni emisiones perjudiciales (“0” Ozono).

DENSIDAD DE IONES EN ENTORNOS NATURALES <1700-25000 IONS/cm³
ION DENSITY IN NATURAL ENVIRONMENTS <1700-25000 IONS/cm³



Eco-Plasma by Pando is a cutting-edge hybrid INTEGRATED SYSTEM that eliminates odours, improves air quality and is totally respectful of the environment. It is an ‘optional’ system that can be integrated into almost all models of Pando Hoods. Its innovative plasma technology is a system capable of disinfecting and sterilising environments, providing a healthier home free of contaminants.

MAXIMUM EFFICIENCY AT HOME

Unlike other systems, the Integrated Eco-Plasma System by Pando is not only designed for the kitchen, but also perfectly purifies the air in the room. Its advanced Bipolar Plasma Ionisation technology allows for:

- Purification of the air, eliminating viruses, bacteria, and allergenic/harmful particles.
- Neutralisation of odours, providing a fresh and clean environment.
- Elimination of contaminants on surfaces, improving the hygiene of the environment.
- Reduction of suspended dust, facilitating its elimination.

ENVIRONMENTALLY FRIENDLY INNOVATION

Thanks to its integration into the hood, Eco-Plasma by Pando offers a sustainable and energy-efficient solution, without generating waste or harmful emissions (“0” Ozone).



BENEFICIOS DEL AIRE IONIZADO

- **Mejor descanso y bienestar:**
Aumenta los niveles de energía, reduce el estrés, mejora el estado de ánimo y contribuye a un sueño reparador.
- **Aceleración del metabolismo**
Favorece la regeneración de tejidos y ayuda en el tratamiento de enfermedades respiratorias.
- **Refuerzo del sistema inmunológico**
Mejora la oxigenación de tejidos y órganos, fortaleciendo las defensas del cuerpo.
- **Aire más limpio y saludable**
Reduce la presencia de contaminantes, gérmenes y virus en el ambiente, garantizando un entorno más seguro.
- **Libre de productos químicos agresivos**
El proceso de purificación no utiliza sustancias húmedas ni deja residuos.
- **Uso de aire o gases no tóxicos y accesibles**
Empieza componentes seguros, asequibles y libres de sustancias dañinas.
- **Respetuoso con el medio ambiente**
Una tecnología limpia, sostenible y libre de emisiones nocivas ("0" Ozono).

BENEFITS OF IONISED AIR

- **Better rest and well-being:**
Increases energy levels, reduces stress, improves mood and contributes to restful sleep.
- **Acceleration of the metabolism:**
Promotes tissue regeneration helping in the treatment of respiratory diseases.
- **Boosting of the immune system:**
Improves the oxygenation of tissues and organs, strengthening the body's defences.
- **Cleaner and healthier air:**
Reduces the presence of pollutants, germs and viruses in the environment, guaranteeing a safer environment.
- **Free of aggressive chemical products:**
The purification process doesn't use wet substances and leaves no residue.
- **Use of non-toxic and accessible air or gases:**
It uses safe, affordable components that are free of harmful substances.
- **Environmentally friendly:**
A clean, sustainable technology that is free of harmful emissions (zero ozone).

NUUESTRA
TECNOLOGÍA

OUR
TECHNOLOGY

SISTEMAS INTEGRADO | INTEGRATED SYSTEM

+ - **Eco-Plasma**
by **Pando**

1

Filters
**ECO
PLASMA**



VALIDATED

• ZERO OZONE EMISSIONS –
MEASURED OZONE
EMISSIONS FROM PLASMA
AIR RAPIDPURE DURING
USE PHASE DOES NOT
EXCEED 0.005 PPM

Una solución innovadora para purificar el aire en la cocina, mejorando la calidad del ambiente y eliminando contaminantes de manera eficiente y sostenible.

INNOVACIÓN EN PURIFICACIÓN DE AIRE

El **Sistema Integrado Eco-Plasma by Pando** se fabrica para las campanas que se destinan a entornos “sin salida de humos” y por tanto para el uso en “recirculación”. Su arquitectura técnica, está formada por un avanzado **ionizador de Plasma Híbrido** y un equipo de última generación de **Filtros de Carbón Activado de Altísima Eficiencia Operativa**, capaces de eliminar en su primer reciclaje las **partículas de olor hasta un 88%** bajo la norma UNE-EN-IEC 61591:2023 y 99% bajo la norma UNE-EN-IEC 13725:2022, además neutraliza los contaminantes como bacterias, virus y alérgenos, creando un ambiente más limpio y saludable en tu cocina.

TECNOLOGÍA DE IONIZACIÓN BIPOLAR

El sistema patentado de purificación de **Pando Integral Cooking** utiliza **ionización Bipolar**, emitiendo iones positivos y negativos similares a los de la naturaleza. Estos iones atrapan partículas, mejorando la respiración, el bienestar y la actividad metabólica, purificando y refrescando el aire al eliminar los contaminantes.

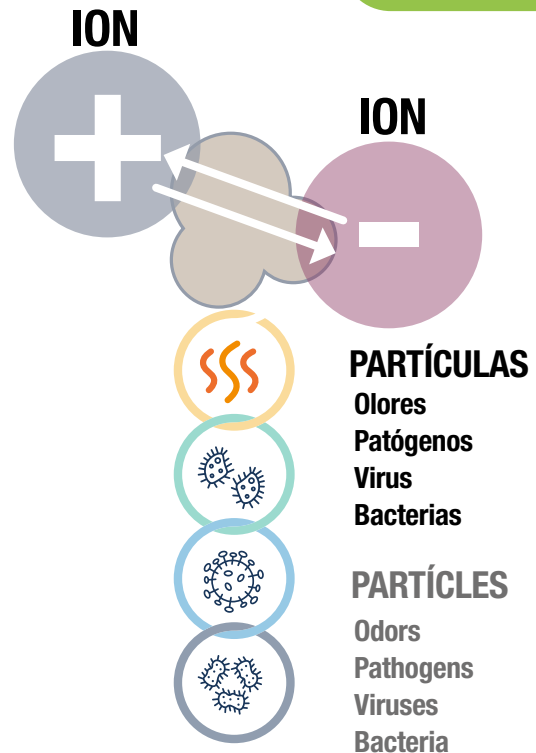

An innovative solution for purifying the air in the kitchen, improving the quality of the environment and eliminating pollutants in an efficient and sustainable way.

INNOVATION IN AIR PURIFICATION

The **Integrated Eco-Plasma System by Pando** is manufactured for hoods designed for ‘smokeless’ environments and therefore for ‘recirculation’ use. Its technical architecture consists of an advanced **Hybrid Plasma Ioniser** and **latest-generation Activated Carbon Filters with Very High Operational Efficiency**, capable of **eliminating odour particles** in their first recycling up to **88%** under the UNE-EN-IEC 61591:2023 standard and 99% under the UNE-EN-IEC 13725: 2022, it also neutralises pollutants such as bacteria, viruses and allergens, creating a cleaner and healthier environment in your kitchen.

BIPOLAR IONISATION TECHNOLOGY

The patented purification system from **Pando Integral Cooking** uses **Bipolar Ionisation**, emitting positive and negative ions similar to those found in nature. These ions trap particles, improving respiration, well-being and metabolic activity, purifying and refreshing the air by eliminating pollutants.

TEST REPORT
ODOUR EXTRACTION TEST
EN IEC 61591

TEST RESULT	
Odour reduction factor, Of	
87,7	[%]
Odour Dispersion Time, ODT	
0	[min]





CARACTERÍSTICAS CLAVES DEL SISTEMA INTEGRADO ECO-PLASMA BY PANDO

Mantenimiento nulo del Ionizador de Plasma:
Gracias a sus emisores de iones auto-limpiantes patentados.

Mayor durabilidad de los filtros:
Con independencia del tipo de cocción, los filtros de **Carbón Activado** son de **Altísima Eficiencia Operativa**, lavables en lavavajillas y reactivables en el horno.

Eficiencia energética:
Minimiza la necesidad de expulsar aire al exterior, ahorrando en calefacción y aire acondicionado.

Larga vida útil:
Unas 50.000 horas de funcionamiento (el equivalente a más de 35 años de uso) con un consumo medio diario estimado de la campana de 4 horas al día.

Seguridad garantizada:
Validado para cero emisiones de ozono.

KEY FEATURES OF THE INTEGRATED SYSTEM ECO-PLASMA BY PANDO

Zero maintenance of the Plasma Ioniser:
Thanks to its patented self-cleaning ion emitters.

Greater durability of the filters:
With a use of more than three years 'depending on the type of cooking', the **Activated Carbon filters** have a **Very High Operational Efficiency** and are also dishwasher-safe and reusable in the oven.

Energy efficiency:
Minimises the need to expel air to the outside, saving on heating and air conditioning.

Extended life:
Around 50,000 hours of operation (the equivalent of more than 35 years of use) with an estimated average daily consumption of the hood of 4 hours a day.

Guaranteed safety:
Validated for zero ozone emissions.

NUUESTRA
TECNOLOGÍA

OUR
TECHNOLOGY

SISTEMAS DE RECIRCULACIÓN RECIRCULATION SYSTEMS

1

SOLUCIONES AVANZADAS DISEÑADAS PARA PURIFICAR EL AIRE

Los sistemas de aire filtrado permiten purificar el aire, eliminando partículas, humos, olores y contaminantes. Al incorporar tecnologías de filtrado de alta eficiencia, como filtros de carbón activado o sistemas de recirculación, permiten mantener el aire limpio y fresco sin necesidad de expulsar el aire al exterior, con lo que optimizan la eficiencia energética, facilitan la instalación y garantizan un ambiente saludable y cómodo en la cocina.

ADVANCED SOLUTIONS DESIGNED TO PURIFY THE AIR

The air filtration systems purify the air by removing particles, smoke, odors, and contaminants. By incorporating high-efficiency filtration technologies, such as activated carbon filters or recirculation systems, they help keep the air clean and fresh without the need to expel air outside, optimizing energy efficiency, simplifying installation, and ensuring a healthy and comfortable environment in the kitchen.

CAMPANAS DE PARED E ISLA WALL & ISLAND COOKER HOODS

Recirculación clásica en pared e islas (salida por la rejilla del tubo de la campana).

Classic recirculation for wall and island units (exit through the side grill in the HOOD CHIMNEY)

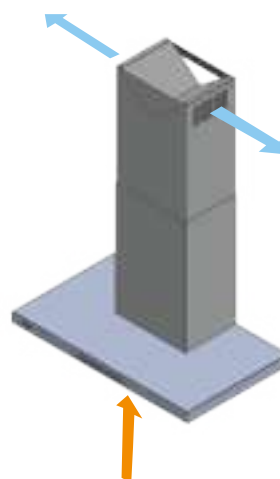

CAMPANAS DE TECHO CEILING COOKER HOODS

Sistema de Recirculación mediante Filtros Cerámicos de Alta Eficiencia a través de Difusor de techo o FCLR-AE.

Recirculation system using high-efficiency ceramic filters through a CEILING DIFUSSER.

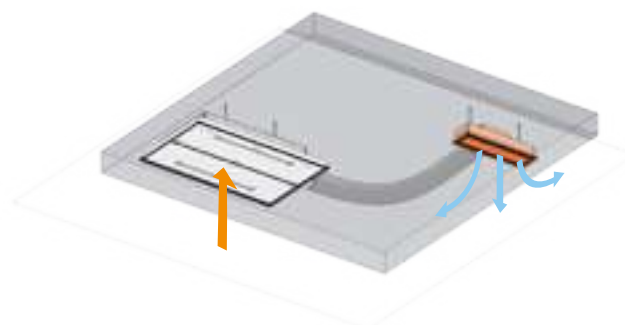

CAMPANAS SOBRE ENCIMERA WORKTOP INTEGRATED COOKER HOODS

Sistema de Recirculación mediante Filtros Cerámicos de Alta Eficiencia a través de Difusor ZÓCALO o FCLR-AE.

Recirculation system using high-efficiency ceramic filters through a PLINTH DIFUSSER.

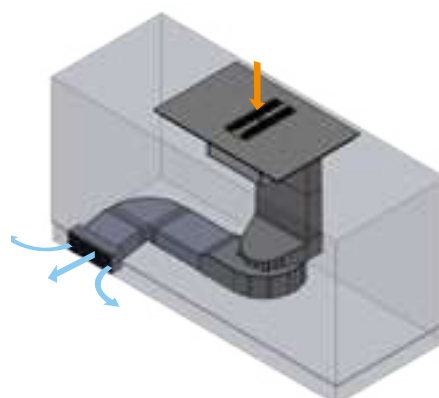

TIPOS DE FILTROS RECIRCULACIÓN TYPES OF RECIRCULATION FILTERS

1

■■■ NANOTEC Filters NANOTEC

ALTA EFICIENCIA, LAVABLE Y REACTIVABLE
EFFICIENCY, WASHABLE AND REACTIVATABLE

Los filtros Nanotec ofrecen un excelente rendimiento en sistemas de recirculación. Gracias a su innovadora composición, pueden lavarse en lavavajillas y reactivarse en horno, prolongando su vida útil. Incorporan esferas de carbón activado con una densidad de 2200 g/m², optimizando la absorción de olores y alcanzando una eficacia del 75%. Su durabilidad supera los 3 años, dependiendo del uso y mantenimiento.

Nanotec filters offer excellent performance in recirculation systems. Thanks to their innovative composition, they can be cleaned in the dishwasher and reactivated in the oven, extending their useful life. They incorporate activated carbon spheres with a density of 2200 g/m², optimising odour absorption and achieving 75% efficiency. Their durability exceeds 3 years, depending on use and maintenance.



■■■ FCLR-AE Filters FCLR

FILTRO DE CARBÓN ACTIVADO ALTA EFICIENCIA
LAVABLES Y REACTIVABLES DE ALTA EFICIENCIA
ACTIVE CARBON FILTERS HIGH-EFFICIENCY REACTIVATED & WASHABLE

Muy superiores en funcionalidad a los FCA, estos nuevos filtros de ALTA EFICIENCIA (FCLR-AE) logran resultados excelentes en sistemas de recirculación. Además, tienen la gran ventaja, gracias a su especial composición y fabricación, de permitir su lavado en lavavajillas y su posterior reactivación en horno. Su durabilidad puede incrementarse por encima de los 2 años, dependiendo también del tipo de cocción y mantenimiento.

Far superior in performance vs the FCA system, these new HIGH-EFFICIENCY CARBON FILTERS (FCLR-AE) provide excellent results. Thanks to their special material they also be dish-washed and reactivated in the oven. They can last over 2 years, depending on the maintenance and type of cooking.



■■■ FCCR-AE Filters FCCR

FILTRO DE CARBÓN ACTIVADO CERÁMICO REACTIVABLE DE ALTA EFICIENCIA
ACTIVE CARBON FILTERS HIGH-EFFICIENCY REACTIVATABLE CERAMIC

Aún más eficaces que los FCLR-AE, se encuentran estos filtros de última generación cerámicos de alta eficiencia (FCCR-AE) que alcanzan mejores resultados de recirculación. Tienen una excelente prestación, debido a su específica construcción, ya que permiten su reactivación en múltiples ocasiones dentro del horno. Su durabilidad es excepcional y supera ampliamente los 3 años. Para ello, es fundamental un buen mantenimiento.



Even more efficient than the FCLR-AE, these latest generation high-efficiency ceramic filters (FCCR - AE) achieve better recirculation results. They have an excellent performance, due to their specific construction, as they can be reactivated multiple times inside the furnace. Their durability is exceptional and far exceeds 3 years. Good maintenance is essential for this.

Durabilidad de los filtros / Duration of the filters

Eficiencia y mantenimiento de los filtros de carbón activado
Carbon Filters: Efficiency and Maintenance Chart



Tipo de filtro Filter type	% de factor de reducción de los olores Smell reduction percentage factor	Durabilidad de los filtros Filter life	Lavables Washable	Reactivables Reactivatable
NANOTEC (1)*	75%	3 años / years	SI / YES	SI / YES
FCLR AE (2)*	88%	2 años / years	SI / YES	SI / YES
FCCR AE (3)*	95%	3 años / years	NO	SI / YES

(1)*
Reactivación en horno a 60° durante 15 minutos
Reactivate in an oven at 60° for 15 minutes

(2)*
Reactivación en horno a 90° durante 60 minutos
Reactivate in an oven at 90° for 60 minutes

(3)*
Reactivación en horno a 180° durante 120 minutos
Reactivate in an oven at 180° for 120 minutes

NUUESTRA
TECNOLOGÍA

OUR
TECHNOLOGY

S.E.C. SYSTEM®

SISTEMA DE INSONORIZACIÓN Y FÁCIL LIMPIEZA
SOUNDPROOF & EASY CLEANING SYSTEM

2

FÁCIL LIMPIEZA / EASY CLEANING S.E.C. SYSTEM®

1. Blindaje interior a través de bandeja interna, acabada en acero inoxidable, para su fácil limpieza.
2. Rejilla interna protectora de doble acción.

1. Lower tray made of stainless steel for easy cleaning.
2. Double-function internal protective grille.

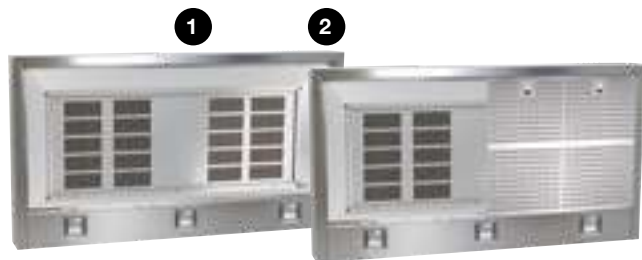

INSONORIZACIÓN / SOUNDPROOF S.E.C. SYSTEM®

3. Motores de última generación integrados en el chasis de la campana con doble turbina de gran diámetro, sustentada por eje central y doble silent-block.
4. Box de ubicación del motor aislado con espumado especial fonoabsorbente, ignífugo y anti-grasa.
5. Tubo flexible de 50cm con doble cámara, realizado en película de aluminio fonoabsorbente y micro-poro.

3. New internal motors. Metal wheel and silent block on center shaft.
4. Motor-housing box insulated with sound absorbent, fireproof, grease-resistant foam.
5. Includes 50cm flexible corrugated tube made of sound absorbent, double-chamber, micropore aluminium film.



2

SEC System PLUS S.E.C. SYSTEM® PLUS MOTOR V.1050 ECO

TODAS LAS CARACTERÍSTICAS DEL
S.E.C. SYSTEM® Y ADEMÁS:
ALL THE FEATURES OF
THE S.E.C. SYSTEM® AND:

6. Nuevo aislamiento especial fonoabsorbente
7. Nuevo box que mejora el rendimiento del motor
8. Nuevo sistema con ajuste de fijación ultrarrápido
9. Nuevos silent-block que amortiguan las vibraciones
10. Chasis reforzado y más rígido que garantiza mejor el sellado acústico
11. Nuevos alerones especiales aerodinámicos

6. New noise-deadening insulation
7. New box to improve motor performance
8. New system with ultra-rapid fixing adjustment
9. New silent block to reduce vibrations
10. Reinforced, more rigid chassis to ensure better noise containment
11. New special aerodynamic flaps

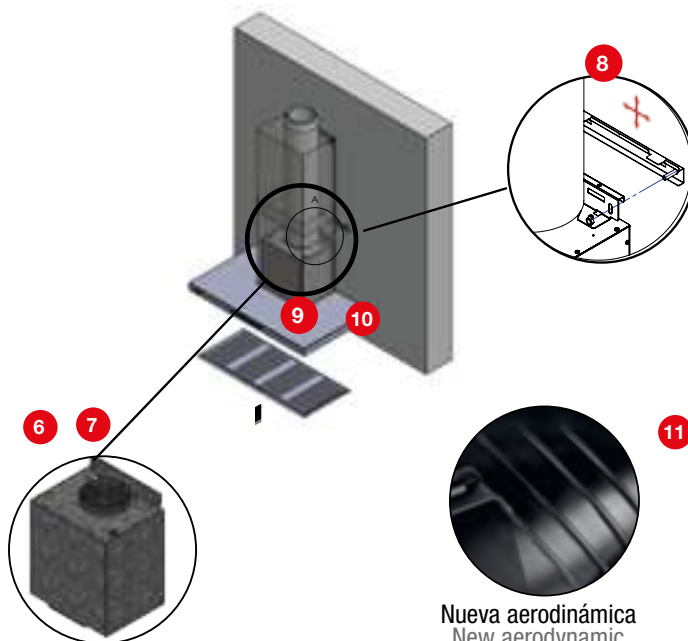

NUESTRA
TECNOLOGÍA

OUR
TECHNOLOGY

SISTEMAS DE FILTROS FILTERS SYSTEMS

3



Filters
ALU

FILTROS DE ALUMINIO ALUMINIUM FILTERS

Realizados en aleación ligera, son esenciales para la captación de partículas grasas y la retención de las mismas. Su particular malla los hace especialmente útiles.

Made of light alloy, these are essential to capture and retain fat particles. Their distinctive grille pattern makes them especially useful.



Filters
INOX

FILTROS INOXIDABLES STAINLESS STEEL FILTERS

Están fabricados idénticamente a los de aluminio pero además incorporan una cobertura en acero inoxidable que los protege y alarga la vida útil, al mismo tiempo que los embellece.

Made identically as the aluminium ones, but they additionally feature a stainless steel cover to protect them and extend their useful life, as well as making them look more attractive.



Filters
PRO

FILTROS DE LABERINTO O PROFESIONALES LABYRINTH OR PROFESSIONAL FILTERS

Realizados total y únicamente en acero inoxidable de primera calidad AISI 304, estos filtros están preparados para el duro trabajo y las altas prestaciones de retención de partículas de grasas. De gran durabilidad y prestaciones, sus características son 100% profesionales.

Manufactured entirely in top-quality AISI 304 stainless steel, these filters are ready to work hard and with a high performance in the retention of fat particles. With great durability and benefits, their characteristics are 100% professional.



Filters
Auto.

DETECCIÓN AUTO. DE SATURACIÓN DE FILTROS AUTOMATIC FILTER SATURATION DETECTION

Sistema automático que informa de cuando es imprescindible la limpieza de los filtros, a través de una señal en la botonera de control.

Automatic system warns you when filters need to be cleaned, via a signal on the control panel.

FILTROS DE 9 CAPAS FILTERS OF 9 LAYERS



- Mayor absorción de grasas
- Mayor velocidad de aspiración
- Reducción de la sonoridad
- Tamaño idóneo para su limpieza en el lavavajillas

- Higher grease absorption
- Higher extraction airflow speed
- Noise reduction
- Ideal size for dishwasher cleaning

NUUESTRA
TECNOLOGÍA

OUR
TECHNOLOGY

SISTEMAS FÁCIL INSTALACIÓN EASY INSTALLATION SYSTEMS

4



CAMPANAS DE TECHO PANDO DOBLE SISTEMA DE FÁCIL INSTALACIÓN



Sistema de instalación con varillas roscadas

Este es el sistema de fijación más tradicional para las unidades de techo. Justo antes de colocar la campana hay que fijar las varillas al hormigón ajustándolas a la altura adecuada. La instalación es tan sencilla como introducir las varillas por los orificios de la campana.

Fitting System using rods

This one is the most traditional fitting system for ceiling units. Just before lifting up the unit the rods must be fixed to the concrete adjusting the right height. Installation is as simple as introducing the rods through the hood side corner holes.



Box-motor giratorio

Permite el cambio de dirección de la salida del aire, facilitando de esta forma su instalación.

Rotary motor-box

Allow airflow exit side change, and making fitting easier this way.

FOR PANDO CEILING HOODS DOUBLE EASY INSTALLATION SYSTEM



Sistema de instalación con grapas a falso techo

La zona de anclaje, se deberá reforzar previamente en relación al peso de la campana de techo a instalar.

Assembly using clamp fixing to the false ceiling

The gripping area previously needs to be reinforced based on ceiling hood weight to be installed.



Cambio del sentido de la apertura de la puerta inferior

Mediante este sistema, es posible cambiar el sentido de apertura de la puerta inferior dependiendo de la orientación que sea más favorable en el momento de su instalación.

Change of door opening direction

Using this system, it is possible to change the opening direction of the bottom door by changing the orientation that is most convenient at the time of installation. installation according to our needs.

NUESTRA
TECNOLOGÍA

OUR
TECHNOLOGY

SISTEMAS FÁCIL INSTALACIÓN EASY INSTALLATION SYSTEMS

4

CAMPANAS DE PARED WALL COOKER HOODS

S.E.C. System® PLUS. V.1050 ECO

NUEVO SISTEMA CON AJUSTE DE FIJACIÓN ULTRARRÁPIDO Y REGULABLE HORIZONTAL Y VERTICALMENTE.

Sistema de anclaje a pared que permite una fijación regulable y rápida de la campana, para así, adaptarse al máximo a las necesidades de la instalación.

NEW SYSTEM FOR ULTRA FAST AND EASY INSTALLATION, ADJUSTABLE HORIZONTALLY AND VERTICALLY.

Wall clamping system that allows the hood to be fixed quickly and easily, so that it can be adapted to the needs of the installation as much as possible.

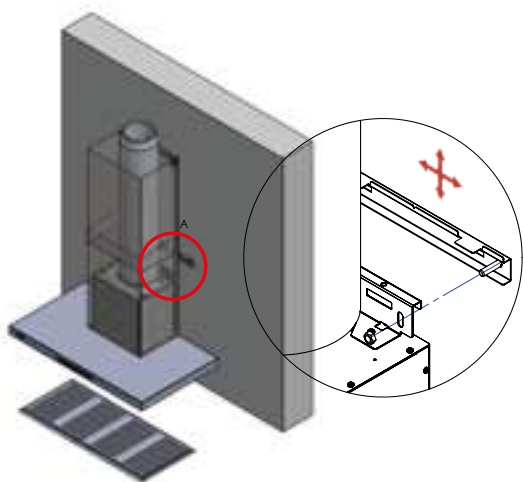

CAMPANAS SOBRE ENCIMERA WORKTOP COOKER HOODS

APROVECHAMIENTO TOTAL DEL ESPACIO INTERIOR

Diseño único de la conducción de humos que permite aprovechar al máximo el espacio útil del mueble para incorporar cajones con fondo de 500 mm.

FULL USE OF THE INTERIOR SPACE

Unique design of smoke extraction offering best-in-class use of the available space in the furniture to allow that 500 mm deep drawers can be installed.

CAMPANAS DE INTEGRACIÓN BUILT IN HOODS

Modelos/Models: TIM-2, TIX

MÁXIMA PROTECCIÓN DEL MUEBLE

ADAPTABILIDAD

Fácil instalación y montaje sin necesidad de cortar el mueble. Adaptable al fondo del mueble para su completa integración.

TUBO EMBELLECEDOR

Protección total del motor y de la parte electrónica, permitiendo también aprovechar al máximo el almacenamiento del mueble.

MAXIMUM CABINET PROTECTION

ADAPTABILITY

Easy installation and fitting with out the need to cut the furniture. Also adaptable to cabinet depth to allow precise fitting.

CHIMNEY EXTENSION

Designed to Offer total protection for the motor and electronics while maximising interior cabinet space.

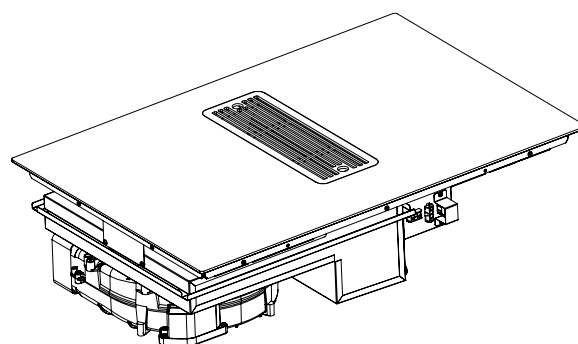
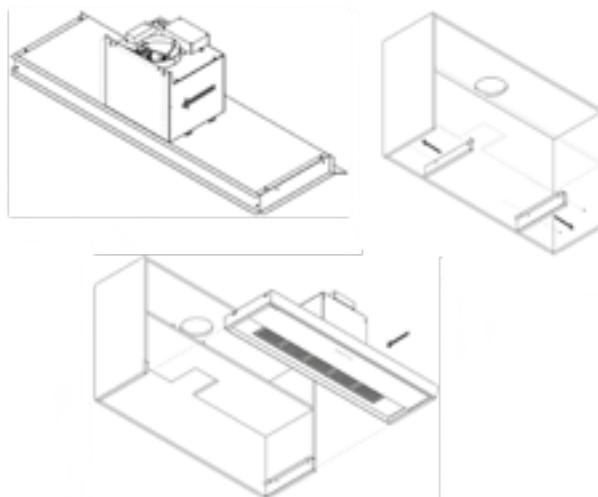

NUUESTRA
TECNOLOGÍA

OUR
TECHNOLOGY

MOTORES ECO EFICIENTES ECO EFFICIENT MOTORS

5

MÁXIMAS PRESTACIONES MÍNIMO CONSUMO EXCELENTE NIVEL SONORO

Pando cuenta con distintas soluciones en sistemas de motorización para adaptarse perfectamente a su proyecto y facilitar al máximo la instalación. Muchos de los sistemas de motores de Pando incorporan sistemas ECO eficientes, de gran rendimiento y muy bajo nivel sonoro. **Versatilidad, adaptabilidad y máximo confort de uso**

MOTORES INTERIORES INTERNAL MOTORS

Motores instalados dentro del cuerpo de la campana. Muchas de las versiones incorporan sistemas ECO eficientes y de gran rendimiento y bajo nivel sonoro.

Motors fitted inside the hood casing. Many of the versions feature ECO efficient systems offering high performance at very low noise levels.



MAXIMUM PERFORMANCE WITH MINIMUM ENERGY CONSUMPTION AND VERY LOW NOISE LEVEL

Pando offer a choice of high-performance motor solutions, with easy installation so allowing you to perfectly adapt the products for ultimate performance. Many of our motor systems feature ECO efficient devices, offering high performance at very low noise levels. **Versatility, adaptability and maximum convenience.**

MOTORES INTERMEDIOS DUCT-IN-LINE REMOTE MOTOR

Motores intermedios de colocación fuera del chasis de la campana. Pueden instalarse en falso techo o bajo cubierta. No pueden instalarse a la intemperie. Gran capacidad de extracción sin ruido.

Duct-in-line remote motors fitted separately from the hood chassis. They can be mounted on a false ceiling or under the roof. They cannot be installed outdoors. High extraction capacity and without noise.

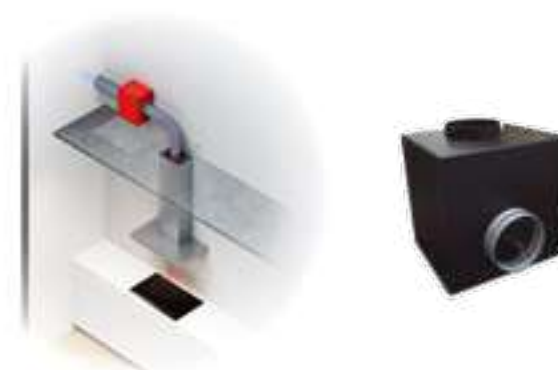

MOTORES DE TEJADO ROOF MOTORS

Motores para su colocación en tejado. Totalmente preparados para cualquier inclemencia del tiempo. Gran capacidad de extracción sin ruido.

Motors for mounting on the roof top of the house. Suitable for all weathers. High extraction capacity with no noise.

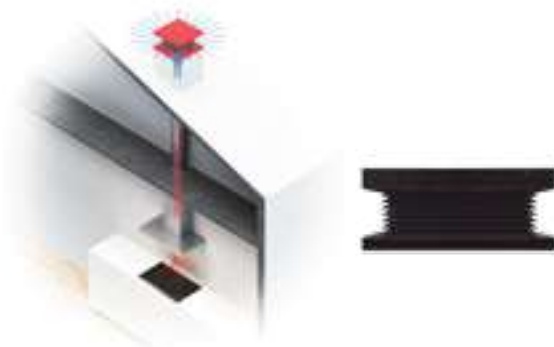

MOTORES MURAL WALL MOTORS

Motores para su colocación adosados al muro exterior de la casa. Totalmente preparados para cualquier inclemencia del tiempo. Gran capacidad de extracción sin ruido.

Motors for mounting on the outside wall of the house. Suitable for all weathers. High extraction capacity with no noise.



ICONOGRAFÍA CAMPANAS DECORATIVAS ICONOGRAPHY OF DECORATIVE COOKERHOODS

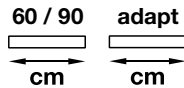

adapt
cm

Longitud frontal de la campana. **adapt**: campana que puede realizarse a medida
Hood front length. **adapt**: Hood that can be custom-made

SEC
System
PLUS

Incorpora sistema S.E.C. Sytem® Plus
Features S.E.C. System®Plus

eco

Sistemas ecoeficientes en ahorro energético
Eco-efficient systems for energy savings

Inox
AISI
304

Campanas realizadas con Acero Inoxidable según norma AISI clasificación 304
Hoods manufactured with Stainless Steel in accordance with AISI standard classification 304

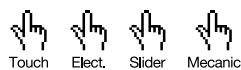

Touch Elect. Slider Mecanic

Tipo de botonera: Touch, electrónica, slider, mecánica
Type of control: Touch, electronic, slider, mechanical



Touch Elect. Pando Wi-Fi

Tipo de mando a distancia. Control mediante App (Wi-Fi). Solo para modelos con motor ECO.
Type of remote control. Control via App (Wi-Fi). Only for models with ECO motor.

Last
TIME

Función Last Time que permite dejar la campana en funcionamiento un tiempo establecido hasta su apagado automático.
Last Time function with automatic Hood turn off.



Filters INOX Filters PRO Filters ALU

Tipo de material de los filtros
Type of filter



Filters NANOTEC Filters FCOR AE Filters FCLR Filters FCLR AE Filters ECO PLASMA

Filtro de carbón activado, filtros de carbón activado reactivables, filtros Nanotec y filtros ECO-PLASMA
Activated carbon filters



Filters Auto.

Sistema con detección automática de saturación de filtros
System with of filter saturation automatic detection



LED 4000K LED Ambient

Tipo de la iluminación principal, temperatura de color y iluminación de cortesía o ambiente.
Temperatura de color de la iluminación principal.
Type of main lighting and courtesy lighting



Pando LED

Sistema de iluminación LED dimmable en intensidad y temperatura de la luz
Dimmable LED lighting in temperature and intensity



tunable dimmable

Iluminación regulable/dimmable en intensidad Tunable: Ajuste del color del LED 2700K a 6000K.
Dimmable LED lighting in intensity Tunable: LED color adjustment 2700K to 6000K.

SIA
Safety

Sistema Inteligente de Seguridad de apagado automático (by Pando)
Features smart automatic safety stop system (by Pando)

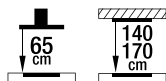

65 cm 140 cm 170 cm

Distancia recomendada entre la campana y la zona de cocción
Recommended distance between cooker hood and cooktop



IND 55-65cm GAS 65 cm IND 50 cm

Distancia recomendada entre la campana y la zona de cocción según esta sea de gas o inducción
Recommended distance between cooker hood and cooktop depending on being gas or induction



ADS All Direction quick fit System

Nuevo sistema de fácil instalación de campanas de techo
New hood gripping system making easier installing and fixing the hood into the recessed ceiling



Air Clean 5h Air Clean 24h

Sistema automático de funcionamiento del motor durante 10 min. cada hora, durante 5 o 24 h.
Automatic working motor system for 10 minutes every hour during 5 or 24 hours.



RAL

Personalizable con todos los colores de la carta RAL
Custom made on any colour from the RAL chart

**CAMPANAS
QUE COMBINAN
ARTE E
INNOVACIÓN
HOODS THAT
COMBINE
ART AND
INNOVATION**





ÍNDICE INDEX



CAMPANAS DECORATIVAS DE TECHO

DECORATIVE COOKER HOODS CEILING

E-201
p.40

E-217
p.42

E-219
p.44

E-221
p.46

E-231
E-232
p.48-50

E-237
p.52

E-250
p.56



E-252
p.60



E-295
p.62

E-297
p.64

SKYRING
p.68

SKYRING LIGHT
p.68



CAMPANAS DE INTEGRACIÓN EN PLACA COCCIÓN

INTEGRATED COOKER HOODS INTO INDUCTION COOKTOP

E-395
E-396
p.72



E-320
p.76

CAMPANAS DE INTEGRACIÓN A MUEBLE

INTEGRATE COOKER HOODS INTO CABINETS

GRM
p.81



EVO
p.82

GTI
p.84

PRO
p.86

NCR
p.88

NEO
p.90

GRV
p.91

GRX
p.92



TIL-2
p.94



TIB-2
p.96

TIM-2
p.98

TIX
p.100

GIM 2
p.102

**BGF SEC
System**
p.104

PGF
p.105

**IES SEC
System**
p.106

**IES SEC
System
Touch**
p.107

ES
p.108

GR20
p.109

GR05
p.109

CAMPANAS DECORATIVAS DE PARED

DECORATIVE COOKER HOODS WALL

P-221
p.114

P-227
p.115

P-300
P-330
p.116

P-401
p.118

P-417
p.120

P-725
p.122

P-732
p.124

P-746
p.112

P-823N
p.126



P-825
p.128

P-826
p.127

P-827
p.130

P-842/6
P-842/11
p.132

P-861
p.134

P-898
p.138

P-1001
p.140

P-2000
P-2000
Vintage
p.142

P-2010
p.144

CAMPANAS DECORATIVAS DE ISLA

DECORATIVE COOKER HOODS ISLAND

I-300
p.152

I-330
p.152

I-825
p.154

I-861
p.156

I-894
Modular
p.158

I-875
p.150



I-897
Cristal
Glass
p.160

I-898
p.162

I-1300
p.166

SKYLOOP
p.168

A modern kitchen interior featuring a wall of horizontal wooden planks. A glowing square light fixture is mounted on the ceiling. In the foreground, a countertop with a dark cooktop is visible, along with a stack of ceramic dishes. To the left, two wooden stools with metal legs are positioned near a smaller countertop with a white teapot and cups.

**CAMPANAS
DE TECHO**

**COOKER
HOODS
CEILING**

E-201
p.40

E-217
p.42

E-219
p.44

E-221
p.46

E-231
E-232
p.48-50

E-237
p.52

E-250
p.56



E-252
p.60



E-295
p.62

E-297
p.64

SKYRING
p.68

SKYRING
LIGHT
p.68



Características y recomendaciones para las campanas de techo

Es esencial leer estas instrucciones, si elegimos para nuestro proyecto, la colocación de una campana de techo:

ASESORAMIENTO TÉCNICO GRATUITO:

Con el fin de certificar que su proyecto tendrá el éxito asegurado, **Pando** le recomienda explícitamente que nos haga llegar el Estudio Técnico de Proyectos para este fin.

Una vez analizado, podremos asegurarle la perfecta viabilidad de uso, con el modelo de campana de techo elegido.

FORMA DEL TECHO:

El techo "ideal" para la colocación de estas unidades de campana, deberá ser completamente diáfano y liso en toda su superficie. Si por razones de diseño, se opta por realizar diferentes alturas o desniveles de techo, entonces debemos establecer que la zona donde este colocada la campana sea totalmente lisa y que tenga un perímetro lo más ancho posible, para evitar posibles pérdidas de aspiración (es necesario enviar plano para determinar si el techo periférico es el óptimo).

ALTURA DE INSTALACIÓN A TECHO:

La distancia recomendada entre la encimera y la campana es de entre 1,40 m a 1,70 m. Para alturas superiores consultar a nuestra División Técnica.

POSICIÓN DE LA CAMPANA:

La campana tiene que estar centrada con la zona de cocción.

REJILLA DE ADMISIÓN DE AIRE:

Para asegurar un excelente funcionamiento de aspiración de la campana, es imprescindible que exista en la cocina una toma constante de entrada de aire; para ello puede servir perfectamente una rejilla de ventilación a ras de suelo.

INSTALACIÓN DE TUBO CONDUCTOR DE HUMO:

Es muy recomendable la utilización de tubos de extracción de humos S.E.C. System® de Pando, que mejoran considerablemente el confort de uso y la insonorización del equipo.

INCLUIDO: Todas las unidades con motorizaciones V.2450 y V.3000 Intermedio Exterior y V.2350 y V.3300 Tejado y V.2200 Interiores, incorporan de serie 5 m de tubo de extracción de humos S.E.C. System® de Ø interior 203 mm y Ø exterior 253 mm.

INCLUIDO: Todos los modelos incorporan de serie 2 m de tubo de extracción de humos espiral 150 circular.

Features and recommendations for ceiling-mounted hoods.

It is very important to read the following instructions, if your project involves fitting a ceiling-mounted cooker hood:

FREE-OF-CHARGE TECHNICAL CUSTOMER SERVICE:

Pando highly recommends you to send us back our "Technical viability form" duly filled in, prior to placing your order. Once our product experts have analyzed your proposal, they will provide you feedback and advice from technical point of view to ensure that your project will be a success and that product performance is optimal.

FORM OF THE CEILING:

The "ideal" ceiling to install these hood units must be completely unobstructed and flat over all of its surface. If for design reasons you choose to have different heights or steps in the ceiling, it must be ensured that the area where the hood is to be fitted is completely flat and covers as wide an area as possible, to avoid any suction losses (you must send us a plan to determine whether the surrounding ceiling is suitable).

CEILING HEIGHT:

Pando recommends that the distance between the cooking hob and the ceiling hood is between 140 and 170 cm. For greater heights consult our Technical Division.

POSITION OF THE HOOD:

The hood must be centred over the cooking area.

AIR INTAKE GRILLE:

To ensure optimal product performance and powerful suction of the hood, it is essential that the kitchen has a constant inflow of fresh air. A ventilation grille at plinth level is a perfect solution for this.

INSTALLING OF THE FLUE PIPE:

Pando highly recommends to use our S.E.C. System® fume extractor flue pipes, as these are very easy to use and install, and clearly reduce the noise generation of the system.

INCLUDED: All units with V.2450 and V.3000 Exterior and V.2350 and V.3300 Roof motors and V.2200 Internal come with 5 m of S.E.C. System® fume extractor flue with interior Ø 203 mm and exterior Ø 253 mm as standard.

INCLUDED: All models come with a 2 m long and 150 diameter circular spiral extractor flue as standard.

Descarga el
Estudio Técnico para Campanas
de Techo y Especiales



Download the Technical
Study for Ceiling and
Special Hoods

Doble sistema de fácil instalación

Double easy installation System

Videos System ADS



Acceso / Access WEB

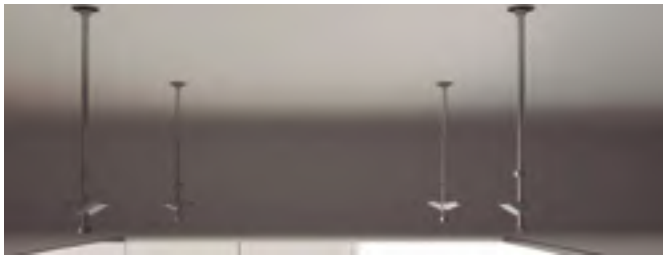

Sistema de instalación con varillas roscadas.

Este es el sistema más tradicional para el montaje de las campanas de techo. Previamente debemos instalar las varillas al techo ajustando la altura deseada. La instalación es tan sencilla como introducir las varillas por los orificios.

Installation System using rods.

This one is the most traditional fitting system for ceiling units. Just before lifting up the unit the rods must be fixed to the concrete adjusting the right height. Installation is as simple as introducing the rods through the hood side corner holes.



Sistema de instalación con grapas directamente a falso techo

La zona de anclaje, se deberá reforzar previamente en relación al peso de la campana de techo a instalar.

Fitting System using fixing metal clamps directly into the false ceiling

The gripping area previously needs to be reinforced based on ceiling hood weight to be installed.



Box-motor giratorio

Permite el cambio de dirección de la salida del aire, facilitando de esta forma su instalación.

Rotary motor-box

Allowing airflow exit side change, and making fitting easier this way.



Cambio del sentido de la apertura de la puerta inferior

Gracias a este sistema, podremos cambiar el sentido de apertura de la puerta inferior dependiendo de la orientación que nos sea más favorable en el momento de su instalación.

Change on door opening direction

This system makes installation easier, as it allows us to adjust the door opening according to your specific needs on site.

OPCIONAL: CONJUNTO DE BOTONERA PARA ENCASTRE A PARED

OPTIONAL: BUTTON PANEL SET FOR EMBEDDING IN WALL



Botonera encastre pared
Wall-mounted button panel

Diámetro tubo pasacables mínimo 25 mm
The min. diameter of lead-through cable must be min. of 25 mm



Modelo Inox / Stainless Steel

Modelo Blanco / White



Medidas Encastre
Built in Sizes

220 x 75 x 50

Ahora todas las campanas de techo pueden incorporar de forma opcional, una botonera de control de la campana encastrada a pared. El sistema incorpora de serie un cableado máximo de 10 m. Excepto la E-237, E-219 y Skyring.

Importante: El conjunto de botonera para encastre a pared, solo se podrá servir junto al pedido de la campana de techo

All ceiling-mounted hoods now optionally feature a control button panel for the hood embedded into the wall. The system comes with up to 10 m of cable as standard. Except E-237, E-219 and Skyring models..

Important: The panel set for embedding into the wall can be only ordered when the order is placed.



E-201

Esmaltado epoxi blanco
White epoxy enamel

	eco PLUS		Last TIME	AIR Clean 5h
			SIA Safety	

Opcionales* / Options*



AirLink



LED 3000K

Filters ECO PLASMA

S.E.C. System®

Motor Interior / Interior Motor

Front. (cm)	Motor	Ø tubo	Clas. Ener.	Ref.
65	V.1130 eco PLUS	Ø150	B	010372

Motor Intermedio exterior

Duct-in-line motor

65	V.1550 eco	Ø150	B	010374
----	-------------------	------	----------	--------

Motor exterior a muro

Remote motor - Wall Outdoor

65	V.1300 eco	Ø150	A	010373
----	-------------------	------	----------	--------

Kits de recirculación / Activated carbon filters kit:

Front. (cm)	Acabado Finished	Tipo	Ref.
65	BLANCO/WHITE	FCRL-AE	1200577

Notas / Notes

AirClean

Sistema automático de funcionamiento del motor 10 min. cada hora durante 5 horas.
Automatic working motor system for 10 minutes every hour during 5 hours.

Opcionales* / Options*

AirLink

Modelo compatible. No se equipa de serie. Imprescindible solicitar en pedido.
Compatible Model. Is not included as standard. Must be ordered.

Sistema de filtrado **ECO PLASMA**
ECO PLASMA filter system

Cambio a LED cálido de 3000K. Suministrado con la campana
LED change to warm light LED 3000K. Available only at the factory

Este modelo puede solicitarse bajo pedido SIN ILUMINACIÓN.
This model can be manufactured WITHOUT LIGHTING on request

Conjunto botonera INOX de encastre a pared.
Stainless steel button panel set for embedding into the wall

Conjunto botonera BLANCO de encastre a pared.
White button panel set for embedding into the wall

(* Los opcionales se suministrarán junto con la campana. Indicar claramente "OPCIONAL" en el pedido e introducir los datos de forma clara.

(* The optionals will be supplied together with the cooker hood. Indicate clearly 'OPTIONAL' in the order and enter the data clearly.



Botonera encastre pared
Button panel set for embedding into the wall



Mando a distancia
Remote Touch Control
Ref. 620062200478



E-201



Altura mínima falso techo
Minimum height of false ceiling
65 cm 205 mm

Medidas encastre
Built in Sizes
65 cm 655 x 655 mm

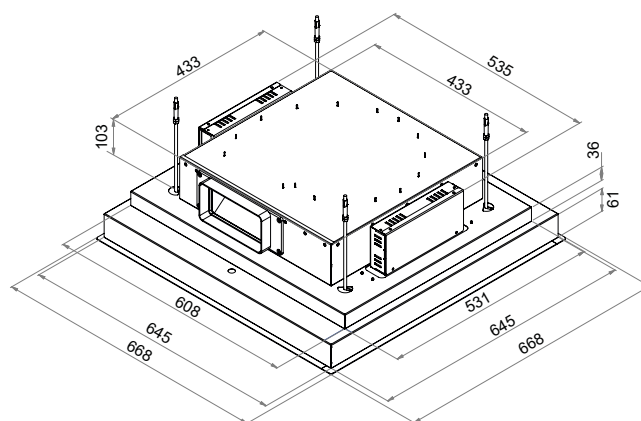

Medidas en / Dimensions in mm

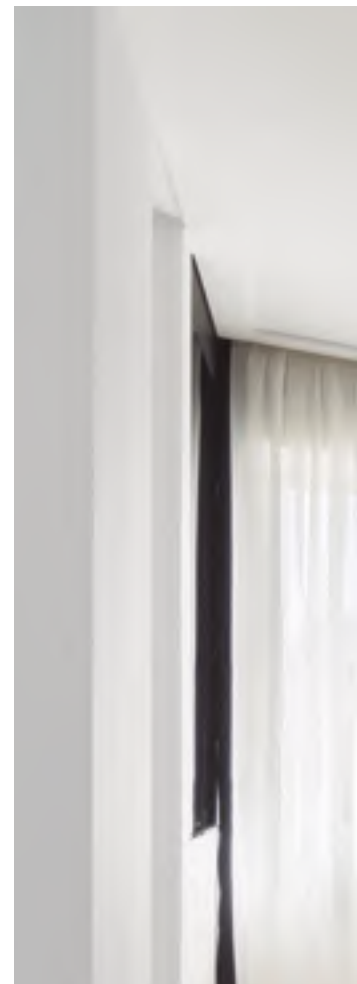

E-217

Esmaltado epoxi blanco (RAL 9016) y cristal blanco
White epoxy enamel (RAL 9016) and white glass

 110 cm	 eco PLUS	 Touch	 Last TIME	 ADS All Direction System quick fix	 Pando Wi-Fi	 Kits Recirculation	
 AIR Clean 5h	 Pando LED	 Filters ALU	 Filters Auto.	 SIA Safety	 140 170 cm	 AirLink	
						 Botonera encastre pared Wall-mounted button panel	 Filters ECO PLASMA

S.E.C. System®

Motor Interior / Interior Motor

Front. (cm)	Motor	Ø tubo	Clas. Ener.	Ref.
110	V.1130 eco PLUS	Ø150	A+	009690

Kits de recirculación / Activated carbon filters kit:

Front. (cm).	Tipo	Ref.
110	FCRL-AE	1202570

Opcionales* / Options*

AirLink

Modelo compatible. No se equipa de serie. Imprescindible solicitar en pedido.
Compatible Model. Is not included as standard. Must be ordered.

Sistema de filtrado ECO PLASMA

ECO PLASMA filter system

Conjunto botonera INOX de encastre a pared.

Stainless steel button panel set for embedding into the wall

Conjunto botonera BLANCO de encastre a pared.

White button panel set for embedding into the wall

(* Los opcionales se suministrarán junto con la campana. Indicar claramente "OPCIONAL" en el pedido e introducir los datos de forma clara.

(* The optionals will be supplied together with the cooker hood. Indicate clearly 'OPTIONAL' in the order and enter the data clearly.

Notas / Notes

AirClean

Sistema automático de funcionamiento del motor 10 min. cada hora durante 5 horas.
Automatic working motor system for 10 minutes every hour during 5 hours.

Box-motor giratorio que permite el cambio de dirección de la salida del aire, facilitando de esta forma su instalación.

Rotary motor-box allowing airflow exit side change, and making fitting easier this way.



Para otras alturas, consultar con nuestra división técnica.
For other heights, please check with our Technical department.



Botonera encastre pared
Button panel set for embedding into the wall



Mando a distancia
Remote Touch Control
Ref. 620062200478



E-217



Doble sistema de fácil instalación
Double easy installation System

Ver pág. 35 / See page 35

Apertura de puerta / Door opening
Box rotativo / Rotary Motor Box

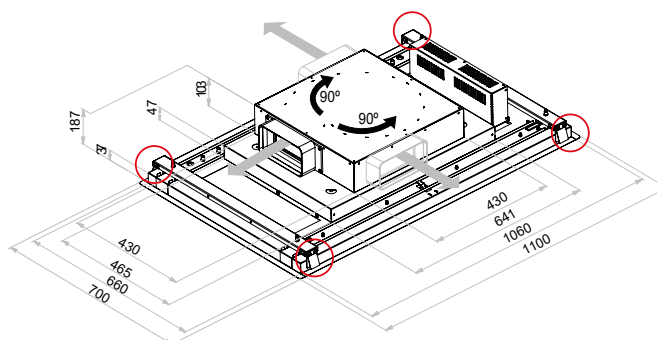
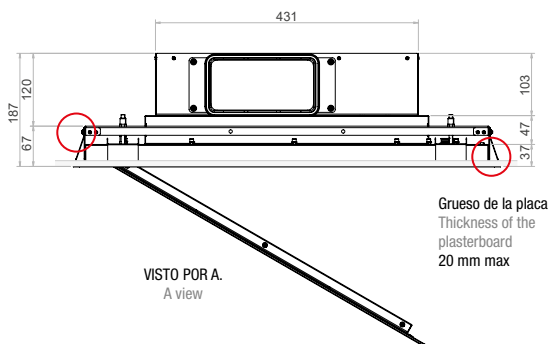

Peso / Weight: 30 kg

Medidas en / Dimensions in mm

Altura mínima falso techo
Minimum height of false ceiling
110 cm 195 mm

Medidas encastre
Built in Sizes
110 cm 1065 x 670 mm

INCLUIDO / INCLUDED

Este modelo incorpora de serie 2 m de tubo de extracción de humos espiral 150 circular
This model comes with a 2 m long and 150 diameter circular spiral extractor flue as standard.



E-219

Esmaltado epoxi blanco
White epoxy enamel

 90 cm	 eco PLUS	 Touch	 Last TIME	<p>Opcionales* / Options*</p> Kits Recirculation
 Pando LED	 Filters ALU	 140 170 cm		

S.E.C. System® Motor Interior / Interior Motor

Front. (cm)	Motor	Ø tubo	Clas. Ener.	Ref.
90	V.1130 eco PLUS	Ø150	A+	010369

Kits de recirculación / Activated carbon filters kit:

Front. (cm)	Tipo	Ref.
90	FCRL-AE	1200576

Notas / Notes

Salida de humos de serie solo lateral largo.
Standard fume outlet only on long side.



Para otras alturas, consultar con nuestra división técnica.
For other heights, please check with our Technical department.



Mando a distancia
Remote Touch Control
Ref. 620062200478



E-219

Con sistema descendente que facilita la aspiración
 With descending system that facilitates aspiration

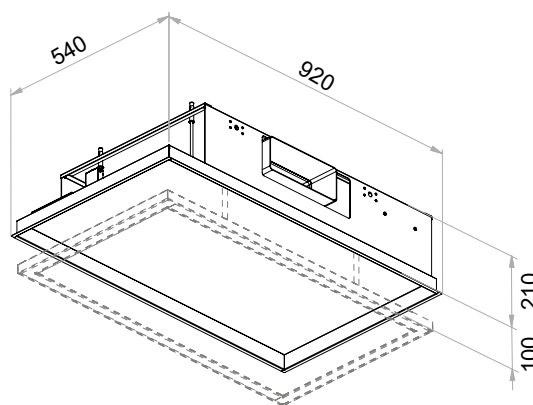
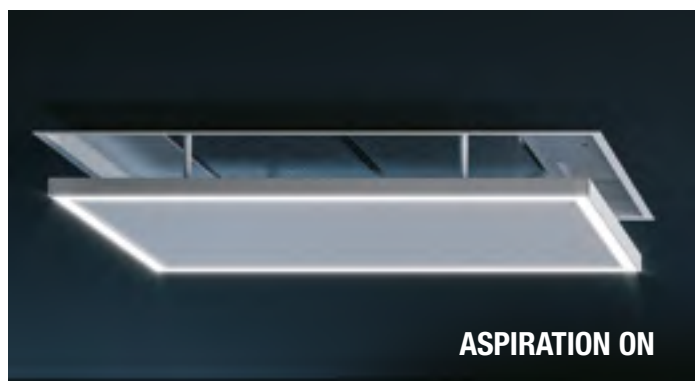

Medidas en / Dimensions in mm

Altura mínima falso techo
 Minimum height of false ceiling
 90 cm 220 mm

Medidas encastrado
 Built in Sizes
 90 cm 890 x 510 mm

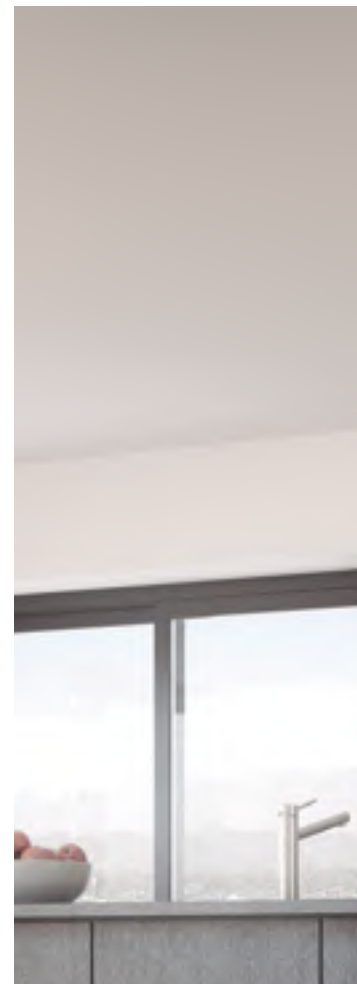
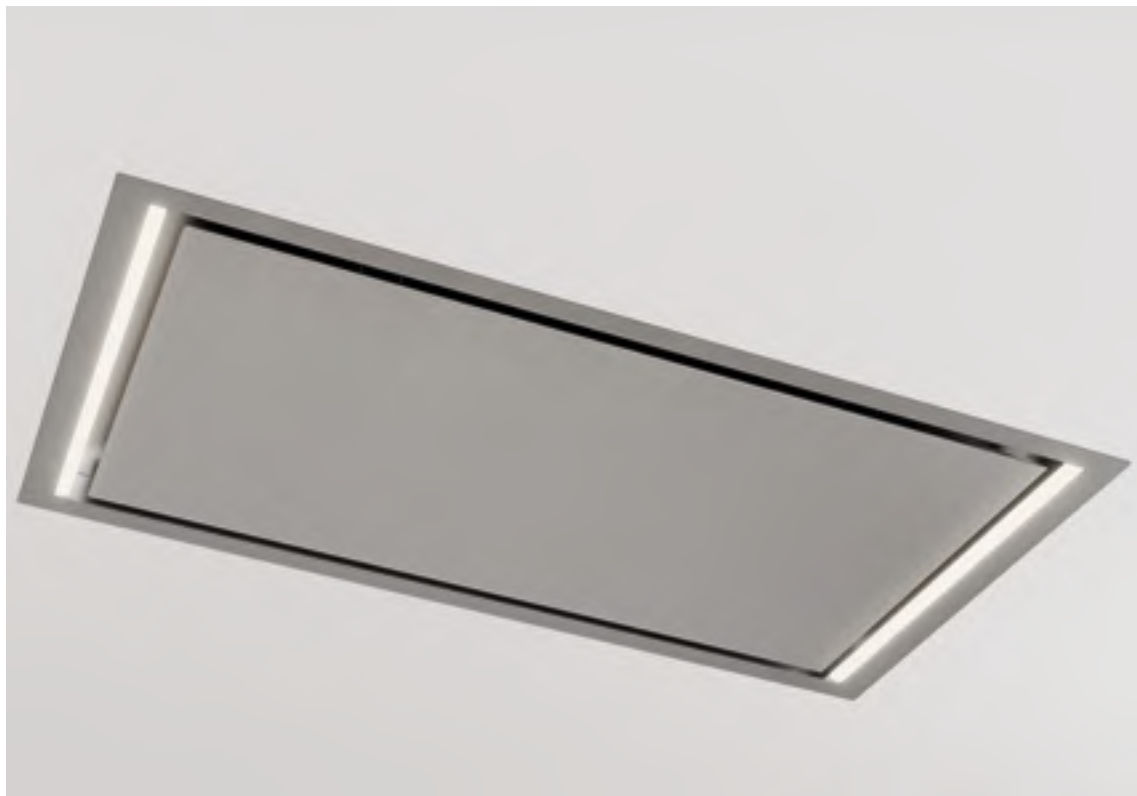

E-221

Inox - Esmaltado epoxi blanco RAL 9016 mate
Stainless Steel - White epoxy enamel RAL 9016 mat

						Opcionales* / Options*

S.E.C. System® Motor Interior / Interior Motor Inox / Stainless Steel

Front. (cm)	Motor	Ø tubo	Clas. Ener.	Ref.
120	V.1130 eco PLUS	Ø150	A	009991.A

Esmaltado blanco / Epoxy white enamel

120	V.1130 eco PLUS	Ø150	A	009992.A
-----	------------------------	------	----------	----------

Kits de recirculación / Activated carbon filters kit:

Front. (cm)	Acabado Finished	Tipo	Ref.
120	BLANCO	FCRL-AE	1202607

Notas / Notes

Box-motor giratorio que permite el cambio de dirección de la salida del aire, facilitando de esta forma su instalación.

Rotary motor-box allowing airflow exit side change, and making fitting easier this way.

Modelo personalizable en cualquier color de la carta RAL, bajo presupuesto
 Customizable model in any color from the RAL chart, on request



Para otras alturas, consultar con nuestra división técnica.
 For other heights, please check with our Technical department.

Opcionales* / Options*

AirLink

Modelo compatible. No se equipa de serie. Imprescindible solicitar en pedido.
 Compatible Model. Is not included as standard. Must be ordered.

Sistema de filtrado ECO PLASMA ECO PLASMA filter system

Cambio a LED cálido de 3000K. Suministrado con la campana
 LED change to warm light LED 3000K. Available only at the factory

Este modelo puede solicitarse bajo pedido SIN ILUMINACIÓN.
 This model can be manufactured WITHOUT LIGHTING on request

Conjunto botonera INOX de encastre a pared.
 Stainless steel button panel set for embedding into the wall

Conjunto botonera BLANCO de encastre a pared.
 White button panel set for embedding into the wall

(*) Los opcionales se suministrarán junto con la campana. Indicar claramente "OPCIONAL" en el pedido e introducir los datos de forma clara.

(*) The optionals will be supplied together with the cooker hood. Indicate clearly 'OPTIONAL' in the order and enter the data clearly.



Botonera encastre pared
 Button panel set for embedding into the wall



Mando a distancia
 Remote Touch Control
 Ref. 620062200478



E-221



Doble sistema de fácil instalación Double easy installation System

Ver pág. 35 / See page 35

Apertura de puerta reversible / Reversible door opening
Box rotativo / Rotary Motor Box

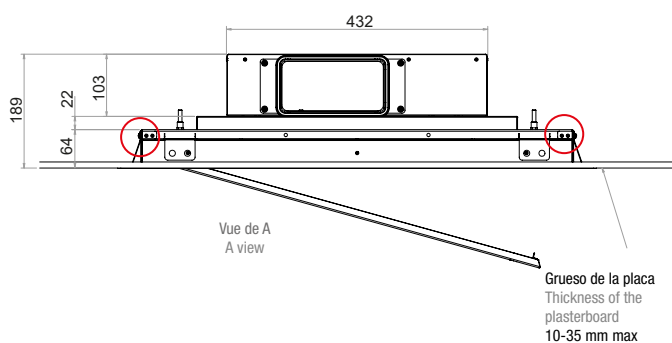

Altura mínima falso techo
Minimum height of false ceiling

120 cm 195 mm

Medidas encastre
Built in Sizes

120 cm 1130 x 725 mm

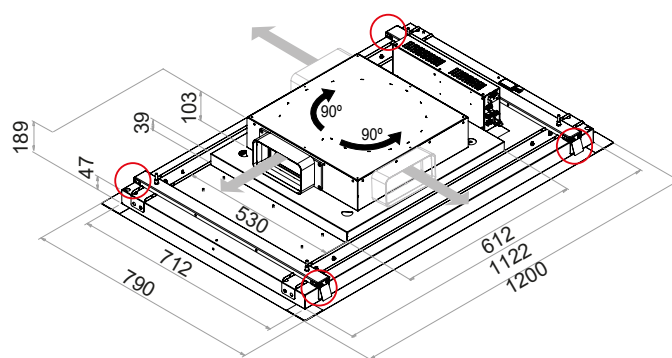

Peso / Weight: 40 kg

Medidas en / Dimensions in mm

INCLUIDO / INCLUDED

Este modelo incorpora de serie 2 m de tubo de extracción de humos espiral 150 circular
This model comes with a 2 m long and 150 diameter circular spiral extractor flue as standard.



E-231

Esmaltado epoxi blanco y cristal blanco
White epoxy enamel and white glass

 130 cm AIR Clean 5h	 eco PLUS	 Touch	 Last TIME	 ADS All Direction System quick fix	 Pando WIFI	Opcionales* / Options* Kits Recirculation	 AirLink
 Pando LED	 Filters ALU	 Filters Auto.	 SIA Safety	 140 170 cm	 Botonera encastre pared Wall-mounted button panel	 Filters ECO PLASMA	

S.E.C. System®

Motor Interior / Interior Motor

Front. (cm)	Motor	Ø tubo	Clas. Ener.	Ref.
130	V.1130 eco PLUS	Ø150	A	009749

Motor Intermedio exterior / Duct-in-line motor

130	V.1550 eco	Ø150	A	009780
130	V.2450 eco	Ø200	A	009781

Motor de tejado / Remote motor -Roof Outdoor

130	V.2350 eco	Ø200	A	009782
-----	-------------------	------	----------	--------

Kits de recirculación / Activated carbon filters kit:

Front. (cm)	Motor	Tipo	Ref.
130	V.1130	FCLR-AE	1202633
130	V.1550, V.2350, V.2450	FCLR-AE	1202598

Notas / Notes

AirClean

Sistema automático de funcionamiento del motor 10 min. cada hora durante 5 horas.
 Automatic working motor system for 10 minutes every hour during 5 hours.

Box-motor giratorio que permite el cambio de dirección de la salida del aire, facilitando de esta forma su instalación.

Rotary motor-box allowing airflow exit side change, and making fitting easier this way.

Salida de humos de serie en motor intermedio y tejado: lateral corto

Standard fume outlet for duct-in-line and roof outdoor motors: short side



Para otras alturas, consultar con nuestra división técnica.
 For other heights, please check with our Technical department.

Opcionales* / Options*

AirLink

Modelo compatible. No se equipa de serie. Imprescindible solicitar en pedido.
 Compatible Model. Is not included as standard. Must be ordered.

Sistema de filtrado ECO PLASMA

ECO PLASMA filter system

Conjunto botonera INOX de encastre a pared.

Stainless steel button panel set for embedding into the wall

Conjunto botonera BLANCO de encastre a pared.

White button panel set for embedding into the wall

(*) Los opcionales se suministrarán junto con la campana. Indicar claramente "OPCIONAL" en el pedido e introducir los datos de forma clara.

(*) The optionals will be supplied together with the cooker hood. Indicate clearly 'OPTIONAL' in the order and enter the data clearly.

INCLUIDO / INCLUDED

Este modelo con motorización V.1130 ECO PLUS incorpora de serie 2 m de tubo de extracción de humos espiral Ø150 circular.

This model with the V.1130 ECO PLUS motor system comes with 2 m of 150 diameter circular spiral extractor flue as standard.

Las unidades con motorizaciones V.2450 Intermedio Exterior y V.2350 Tejado, incorporan de serie 5 m de tubo de extracción de humos SEC System® de Ø203 mm interior y Ø253 mm exterior.

This model with the V.2450 duct-in-line remote motor and V.2350 roof motor system comes with 5 m of S.E.C. fume extractor flue as standard System®, interior Ø 203 mm and exterior Ø 253.



Botonera encastre pared
 Button panel set for embedding into the wall



Mando a distancia
 Remote Touch Control
 Ref. 620062200478



Doble sistema de fácil instalación
Double easy installation System

Ver pág. 35 / See page 35

E-231

Motor Interior / Interior Motor

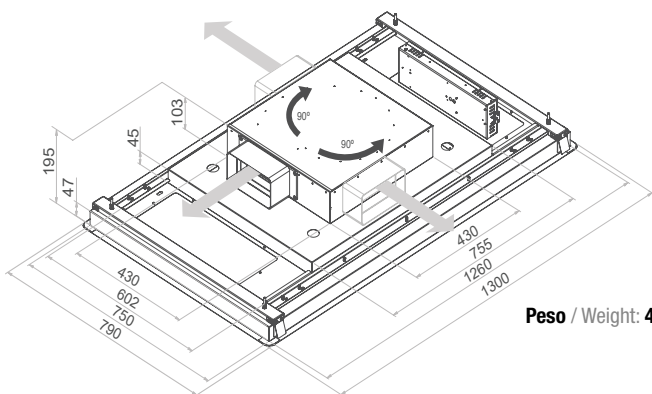

Peso / Weight: 45 kg

Motor Intermedio exterior / Duct-in-line motor

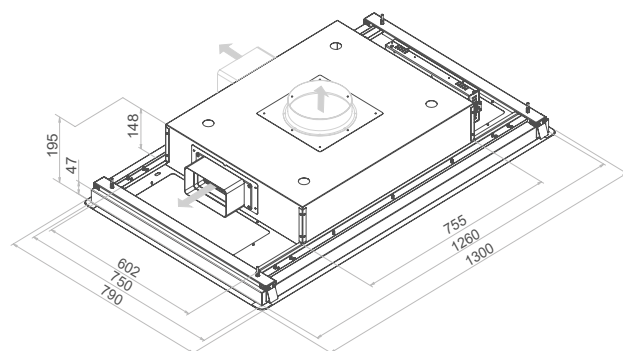

Apertura de puerta / Door opening

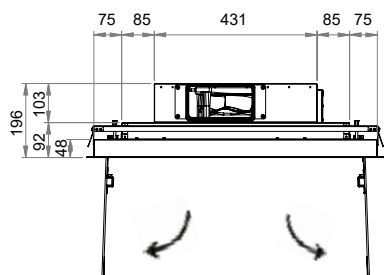

Vista de A
A view

Grueso de la placa
Thickness of the
plasterboard
20 mm max

Apertura de puerta / Door opening

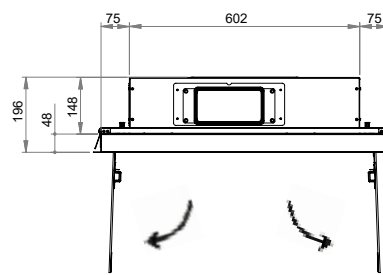

Medidas en / Dimensions in mm

Altura mínima falso techo

Minimum height of false ceiling

Motor Int 200 mm

Motor Ext Ø 200 300 mm

Motor Ext □ 260 x 100 200 mm

Medidas encastre

Built in Sizes

130 1268 x 763

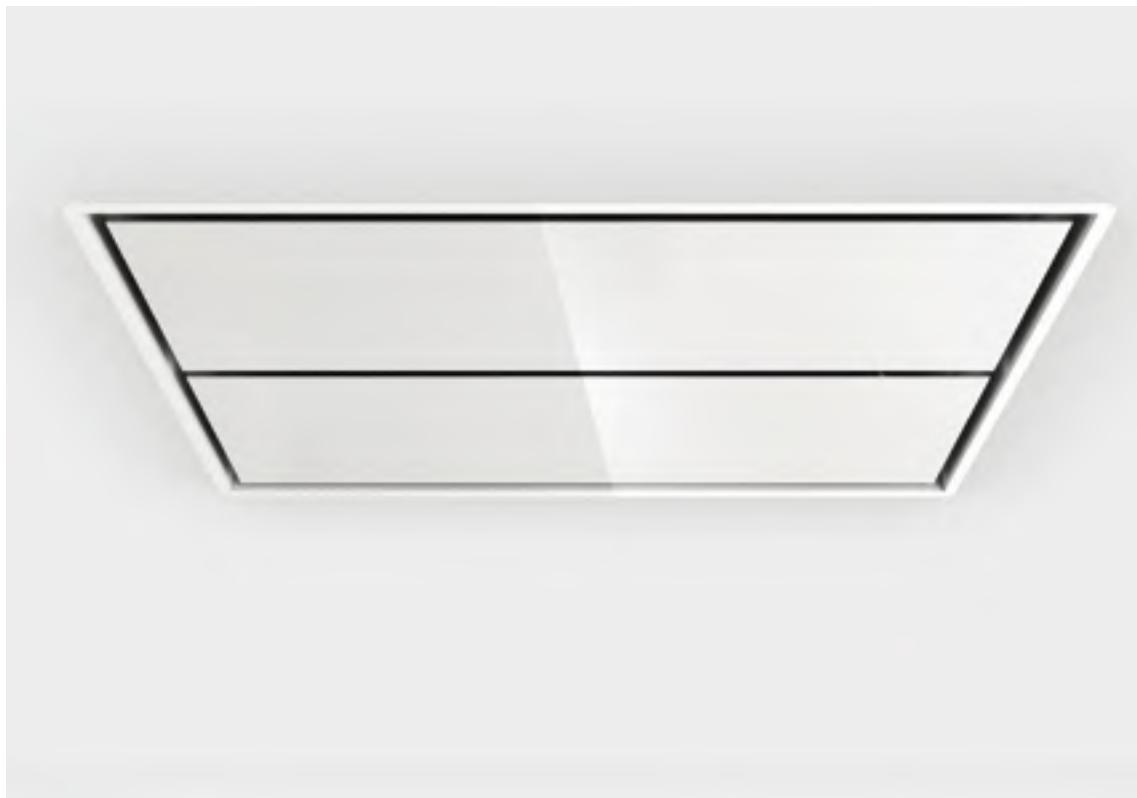

E-232

Esmaltado epoxi blanco y cristal blanco
White epoxy enamel and white glass

	eco PLUS		Last TIME	AIR Clean 5h		Opcionales* / Options*
			SIA Safety			Kits Recirculation
						AirLink
						Botonera encastre pared Wall-mounted button panel

S.E.C. System®

Motor Interior / Interior Motor

Front. (cm)	Motor	Ø tubo	Clas. Ener.	Ref.
130	V.1250 eco	Ø150	A++	009927

Kits de recirculación / Activated carbon filters kit:

Front. (cm)	Tipo	Ref.
130	FCRL-AE	1202598

Opcionales* / Options*

AirLink

Modelo compatible. No se equipa de serie. Imprescindible solicitar en pedido.
Compatible Model. Is not included as standard. Must be ordered.

Conjunto botonera INOX de encastre a pared.
Stainless steel button panel set for embedding into the wall

Conjunto botonera BLANCO de encastre a pared.
White button panel set for embedding into the wall

(*) Los opcionales se suministrarán junto con la campana. Indicar claramente "OPCIONAL" en el pedido e introducir los datos de forma clara.

(*) The optionals will be supplied together with the cooker hood. Indicate clearly 'OPTIONAL' in the order and enter the data clearly.

Notas / Notes

AirClean

Sistema automático de funcionamiento del motor 10 min. cada hora durante 5 horas.
Automatic working motor system for 10 minutes every hour during 5 hours.

Salida de humos de serie: Lateral largo, lateral corto o techo. Indicar en pedido
Standard fume outlet option: long side, short side or ceiling, to be specified on order



Para otras alturas, consultar con nuestra división técnica.
For other heights, please check with our Technical department.



Botonera encastre pared
Button panel set for embedding into the wall



Mando a distancia
Remote Touch Control
Ref. 620062200478



E-232

Motor Interior / Interior Motor

Apertura de puerta / Door opening

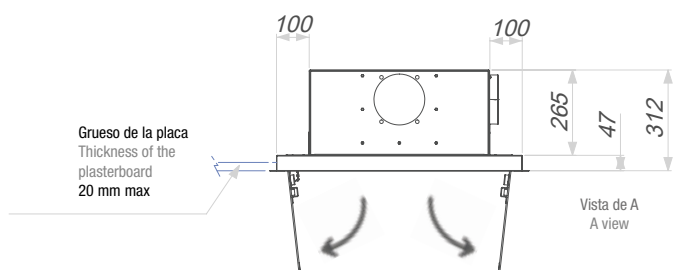

Altura mínima falso techo
Minimum height of false ceiling
130 cm 320 mm

Medidas encastre
Built in Sizes
130 cm 1268 x 758 mm

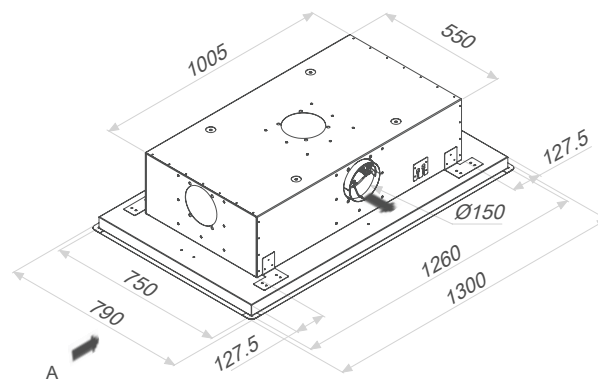

Medidas en / Dimensions in mm





E-237

Esmaltado epoxi blanco RAL 9003 y cristal blanco
White epoxy enamel RAL 9003 and white glass





Touch Down Cleaning System

El sistema de limpieza y mantenimiento de la campana incorpora motor que desciende la unidad de filtrado y el cristal hasta la altura recomendada. (Patente UE N° registro ES2723714 publicado 15.10.2021)

The cleaning and maintenance system of the hood incorporates a motor that lowers the filtering unit and the glass to the recommended height (EU Patent number ES2723714 published 15.10.2021).

E-237

Esmaltado epoxi blanco RAL 9003 y cristal blanco
White epoxy enamel RAL 9003 and white glass

 130 cm	 eco PLUS	 Touch	 Last TIME	 SIA Safety	 LED 3000K	 Filters ALU	 Filters Auto.	 Filters ECO PLASMA	 Kits Recirculation	 SAP
										Sistema anti atrapamientos de Pando Safe Slide Down System

S.E.C. System®

Motor Interior / Interior Motor

Front. (cm)	Motor	Ø tubo	Clas. Ener.	Ref.
130	V.1130 eco PLUS	Ø150	A	009951

Motor Intermedio exterior / Duct-in-line motor

130	V.1550 eco	Ø150	A+	009961
130	V.2450 eco	Ø200	A	009962

Motor de tejado / Remote motor -Roof Outdoor

130	V.2350 eco	Ø200	A	009963
-----	------------	------	---	--------

Kits de recirculación / Activated carbon filters kit:

Front. (cm).	Tipo	Ref.
130	DIF. TECHO IX	009920
130	DIF. TECHO BL	009960

Opcionales* / Options*

Sistema de filtrado **ECO PLASMA**
ECO PLASMA filter system

Cambio a LED cálido de 3000K. Suministrado con la campana
LED change to warm light LED 3000K. Available only at the factory

(* Los opcionales se suministrarán junto con la campana. Indicar claramente "OPCIONAL" en el pedido e introducir los datos de forma clara.

(* The optionals will be supplied together with the cooker hood. Indicate clearly 'OPTIONAL' in the order and enter the data clearly.

Notas / Notes

Recorrido estándar del cable 1 m. Máximo posible 1,40 m. (configurable en fábrica).
Standard cable length 1 m. Maximum possible 1.40 m. (factory configurable).



(*1) Si la distancia entre la campana y la zona de cocción es diferente a la señalada, ésta se debe indicar claramente en el pedido. Así determinaremos la longitud correcta de los tensores.

If the distance between the hood and the cooking zone is different from the specified distance, this must be clearly stated in the order. This will enable us to determine the correct length of the tensioners.



Mando a distancia
Remote Touch Control
Ref. 620062200478



E-237

Motor Interior / Interior Motor

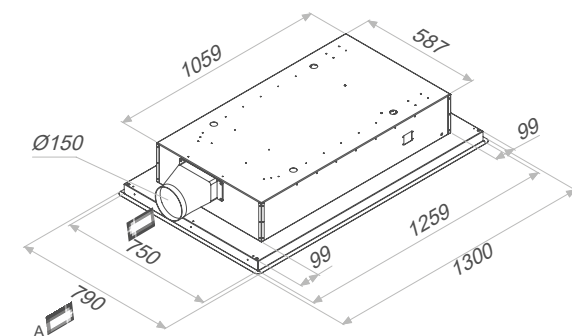

Apertura de puerta / Door opening

Grueso de la placa
Thickness of the
plasterboard
20 mm max

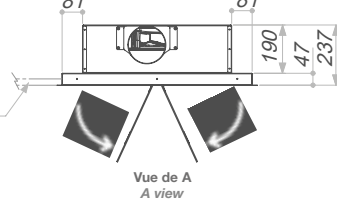

Altura mínima falso techo Minimum height of false ceiling

Motor Int	250 mm
Motor Ext Ø 200	300 mm
Motor Ext □ 260 x 100	250 mm

Medidas encastre Built in Sizes

130	1268 x 758
-----	------------

Motor Intermedio exterior / Duct-in-line motor

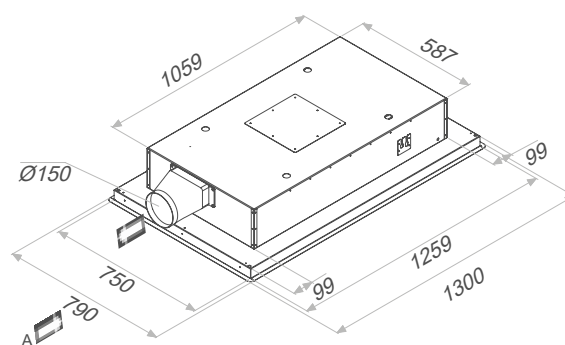

Medidas en / Dimensions in mm

INCLUIDO / INCLUDED

Este modelo con motorización V.1130 ECO PLUS incorpora de serie 2 m de tubo de extracción de humos espiral Ø150 circular.

This model with the V.1130 ECO PLUS motor system comes with 2 m of 150 diameter circular spiral extractor flue as standard.

Las unidades con motorizaciones V.2450 Intermedio Exterior y V.2350 Tejado, incorporan de serie 5 m de tubo de extracción de humos SEC System® de Ø203 mm interior y Ø253 mm exterior.

This model with the V.2450 duct-in-line remote motor and V.2350 roof motor system comes with 5 m of S.E.C. fume extractor flue as standard System®, interior Ø 203 mm and exterior Ø 253.





E-250

Inox - Esmaltado epoxi blanco o negro
Stainless Steel - White or black epoxy enamel

Model. 160 cm

Model. 190 cm



E-250 Inox - Esmaltado epoxi blanco o negro Stainless Steel - White or black epoxy enamel

							Opcionales* / Options* 	

S.E.C. System® Motor Interior / Interior Motor

Front. (cm)	Motor	Ø tubo	Clas. Ener.
130	V.1130 eco PLUS	Ø150	A

Inox
Stainless Steel

Esmaltado blanco
White enamel
RAL 9003

Esmaltado
Negro Satinado
Black satin enamel

Motor Intermedio exterior / Duct-in-line motor

130	V.1550 eco	Ø150	A+
	V.2450 eco	Ø200	A+
160	V.2450 eco	Ø200	A+
190	V.2450 eco	Ø200	A

Motor de tejado / Remote motor -Roof Outdoor

130	V.2350 eco	Ø200	A+
160	V.2350 eco	Ø200	A+
190	V.2350 eco	Ø200	A

Kits de recirculación / Activated carbon filters kit:

Front. (cm).	Motor	Tipo	Ref.
130	V.1130, V.1550, V.2350, V.2450	FCRL-AE	1202526
160	V.2350, V.2450	FCRL-AE	1202604
190	V.2350, V.2450	FCRL-AE	1202527

Opcionales* / Options*

AirLink

Modelo compatible. No se equipa de serie. Imprescindible solicitar en pedido.
Compatible Model. Is not included as standard. Must be ordered.

Sistema de filtrado ECO PLASMA

ECO PLASMA filter system

Opción plafón de iluminación curvado. Indicar en el pedido
Curved Lighting panel as option to indicate in the order

Conjunto botonera INOX de encastre a pared.
Stainless steel button panel set for embedding into the wall

Conjunto botonera BLANCO de encastre a pared.
White button panel set for embedding into the wall

(*) Los opcionales se suministrarán junto con la campana. Indicar claramente "OPCIONAL" en el pedido e introducir los datos de forma clara.

(*) The optionals will be supplied together with the cooker hood. Indicate clearly 'OPTIONAL' in the order and enter the data clearly.

Notas / Notes

Salida de humos de serie lateral corto para motor interior
Standard short side or ceiling fume outlet for interior motor

Salida de humos lateral largo, indicar en pedido
Long side exit, has to be mentioned in the order

Modelo personalizable en cualquier color de la carta RAL. Bajo presupuesto.
Customizable model in any color from the RAL chart. On request.

La campana de 130 y 160 cm incorporan 2 filtros y 1 zona de iluminación.
El modelo de 190 cm. incorpora 3 filtros y 2 zonas de iluminación
The 130 and 160 cm hood includes 2 filters and 1 lighting area.
The 190 cm model. includes 3 filters and 2 lighting areas.



Para otras alturas, consultar con nuestra división técnica.
For other heights, please check with our Technical department.



Botonera encastre pared
Button panel set for embedding into the wall



Mando a distancia
Remote Touch Control
Ref. 620062200478



Model. 160 cm

E-250

Motor Interior / Interior Motor

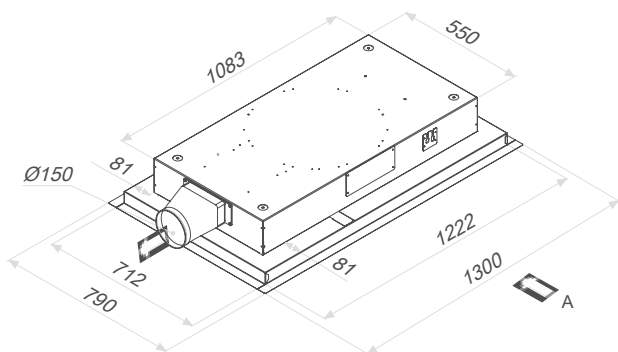

Apertura de puerta / Door opening

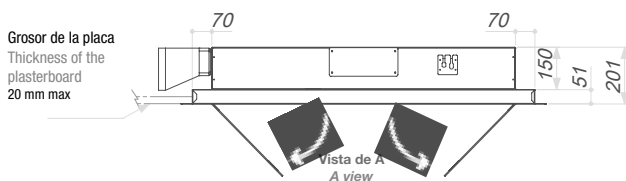

Altura mínima falso techo Minimum height of false ceiling

Motor Int	210 mm
Motor Ext Ø 200	300 mm
Motor Ext 260 x 100	210 mm

Medidas encastre Built in Sizes

130 cm	1230 x 720
160 cm	1485 x 720
190 cm	1825 x 720

Motor Intermedio exterior / Duct-in-line motor

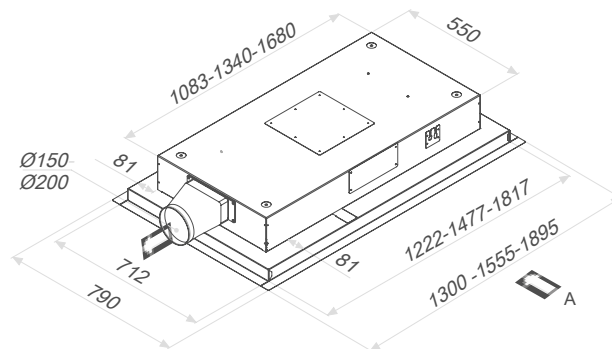

Medidas en / Dimensions in mm

INCLUIDO / INCLUDED

Este modelo con motorización V.1130 ECO PLUS incorpora de serie 2 m de tubo de extracción de humos espiral Ø150 circular.

This model with the V.1130 ECO PLUS motor system comes with 2 m of 150 diameter circular spiral extractor flue as standard.

Las unidades con motorizaciones V.2450 Intermedio Exterior y V.2350 Tejado, incorporan de serie 5 m de tubo de extracción de humos SEC System® de Ø203 mm interior y Ø253 mm exterior.

This model with the V.2450 duct-in-line remote motor and V.2350 roof motor system comes with 5 m of S.E.C. fume extractor flue as standard System®, interior Ø 203 mm and exterior Ø 253.

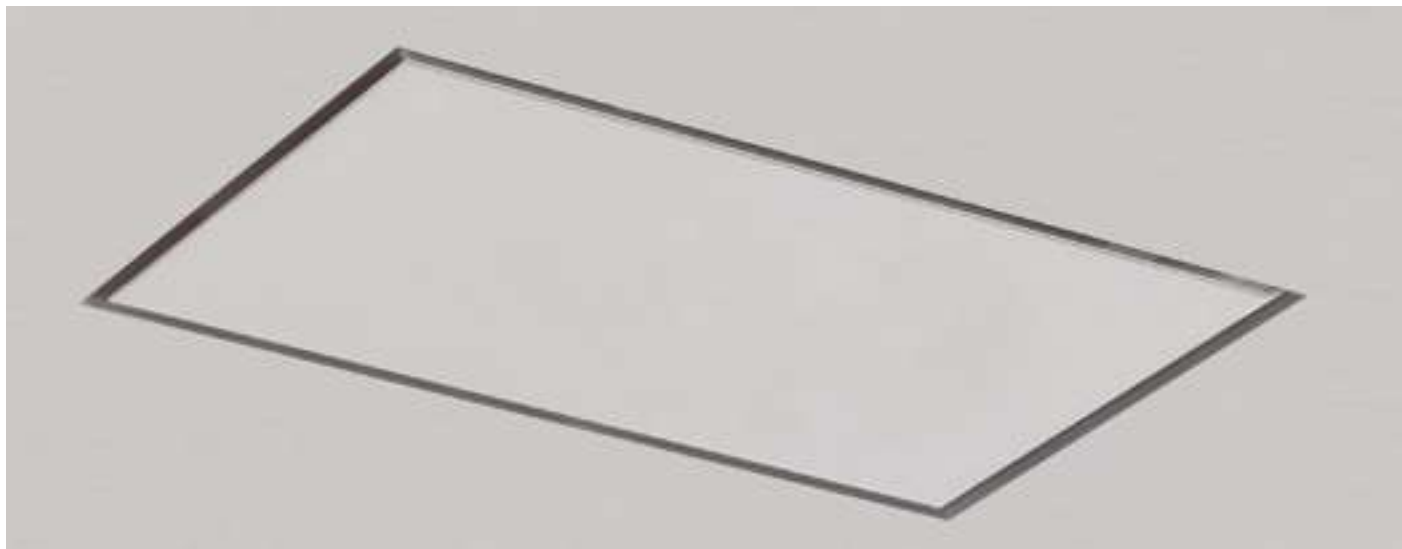

E-252

Inox - imprimación puertas
Stainless Steel - Backlit glass



La campana que te permite pintarla igual que el techo
The cooker hood that allows you to paint it the same as the ceiling.

						Opcionales* / Options*		

S.E.C. System® Motor Interior / Interior Motor

Front. (cm)	Motor	Ø tubo	Clas. Ener.	Ref.
95	V.1130 eco PLUS	Ø150	A+	010214
95	V.1250 eco	Ø150	A+	010856
120	V.1130 eco PLUS	Ø150	A	010218
120	V.1250 eco	Ø150	A	010857

Motor Intermedio exterior / Duct-in-line motor

95	V.1550 eco	Ø150	A+	010215
	V.2450 eco	Ø200	A	010216
120	V.1550 eco	Ø150	A	010219
	V.2450 eco	Ø200	A	010220

Motor de tejado / Remote motor -Roof Outdoor

95	V.2350 eco	Ø200	A+	010217
120	V.2350 eco	Ø200	A	010221

Kits de recirculación / Activated carbon filters kit:

Front. (cm).	Acabado Finished	Tipo	Ref.
95,120	BLANCO	FCRL-AE	1202570

Notas / Notes

AirClean

Sistema automático de funcionamiento del motor 10 min. cada hora durante 5 horas.
Automatic working motor system for 10 minutes every hour during 5 hours.

Caja motor rotativa : La salida de humos puede cambiarse gracias a la caja motor rotativa
Motor Box rotary : Exit position can be changed thanks to its rotative motor box



Para otras alturas, consultar con nuestra división técnica.
For other heights, please check with our Technical department.



La instalación de esta campana debe realizarse antes de colocar y cerrar el falso techo
The installation of this cooker hood must be carried out before the false ceiling is installed and closed

Opcionales* / Options*

AirLink

Modelo compatible. No se equipa de serie. Imprescindible solicitar en pedido.
Compatible Model. Is not included as standard. Must be ordered.

Sistema de filtrado **ECO PLASMA**
ECO PLASMA filter system

Este modelo puede solicitarse bajo pedido SIN ILUMINACIÓN.
This model can be manufactured WITHOUT LIGHTING on request

Conjunto botonera INOX de encastre a pared.
Stainless steel button panel set for embedding into the wall

Conjunto botonera BLANCO de encastre a pared.
White button panel set for embedding into the wall

(*) Los opcionales se suministrarán junto con la campana. Indicar claramente "OPCIONAL" en el pedido e introducir los datos de forma clara.

(*) The optionals will be supplied together with the cooker hood. Indicate clearly 'OPTIONAL' in the order and enter the data clearly.

INCLUIDO / INCLUDED

Este modelo con motorización V.1130 ECO PLUS incorpora de serie 2 m de tubo de extracción de humos espiral Ø150 circular.

This model with the V.1130 ECO PLUS motor system comes with 2 m of 150 diameter circular spiral extractor flue as standard.

Las unidades con motorizaciones V.2450 Intermedio Exterior y V.2350 Tejado, incorporan de serie 5 m de tubo de extracción de humos SEC System® de Ø203 mm interior y Ø253 mm exterior.

This model with the V.2450 duct-in-line remote motor and V.2350 roof motor system comes with 5 m of S.E.C. fume extractor flue as standard System®, interior Ø 203 mm and exterior Ø 253.



Botonera encastre pared
Button panel set for embedding into the wall



Mando a distancia
Remote Touch Control
Ref. 620062200478

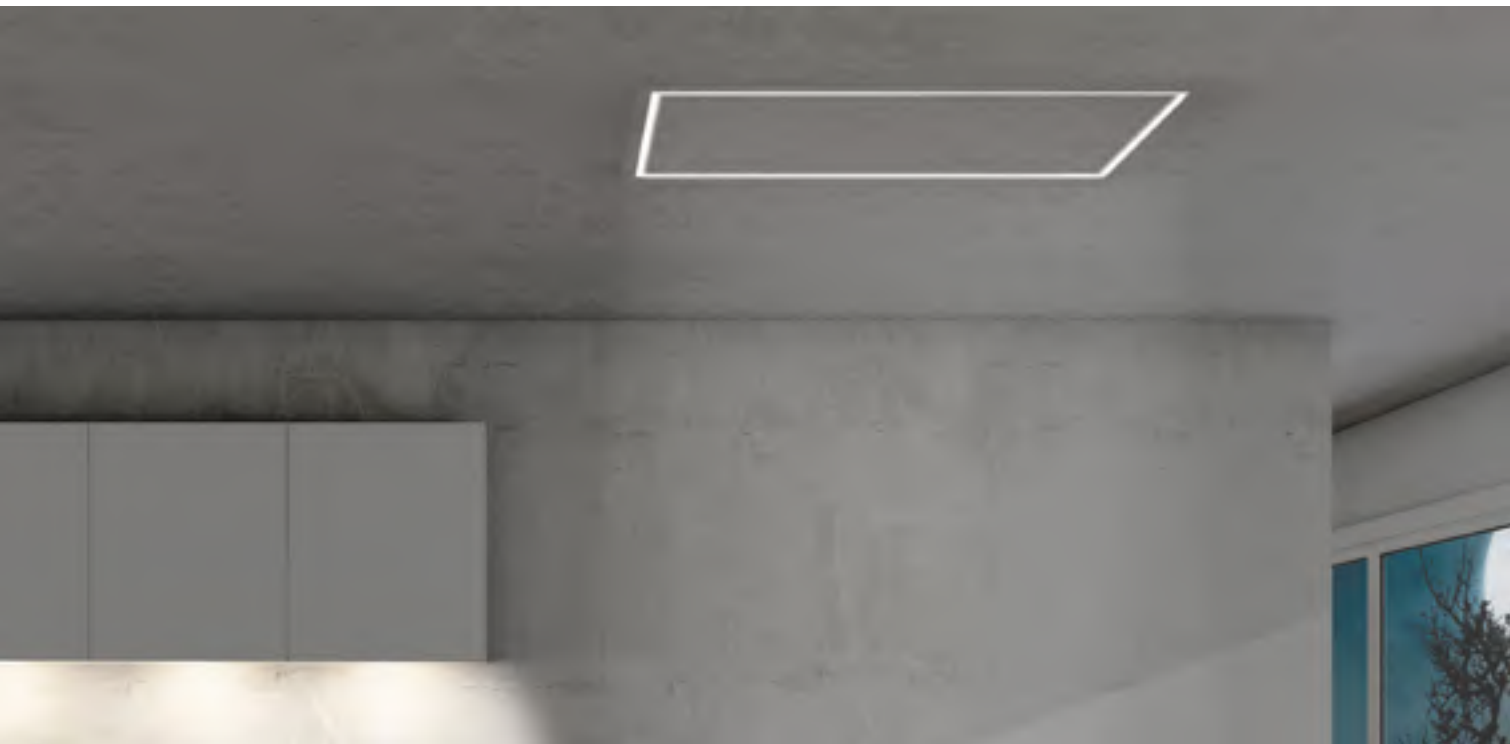

E-252

Motor Interior / Interior Motor

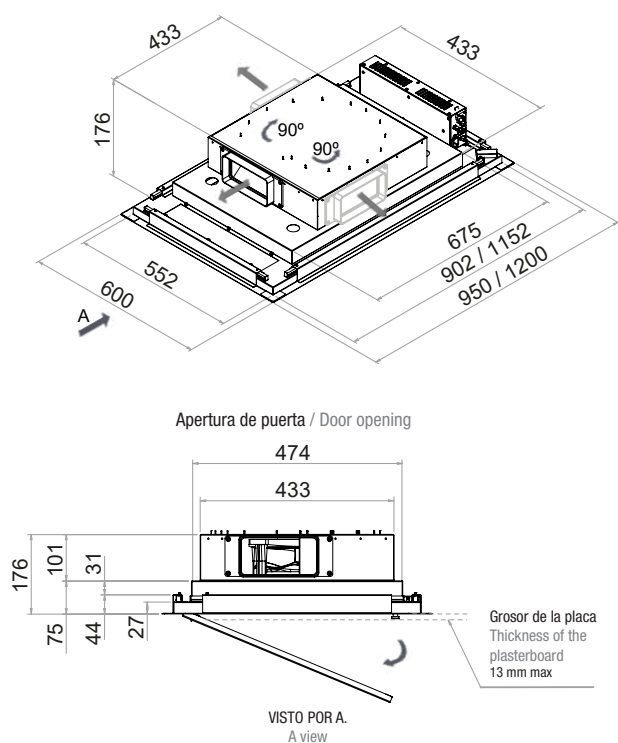

Altura mínima falso techo Minimum height of false ceiling

Motor Int.	200 mm
Motor Int. V.1250	300 mm
Motor Ext. Ø 200	300 mm
Motor Ext. □ 260 x 100	200 mm

Medidas Encastre Built in Sizes

95 cm	562 x 912
120 cm	562 x 1162

Motor Intermedio exterior / Duct-in-line motor

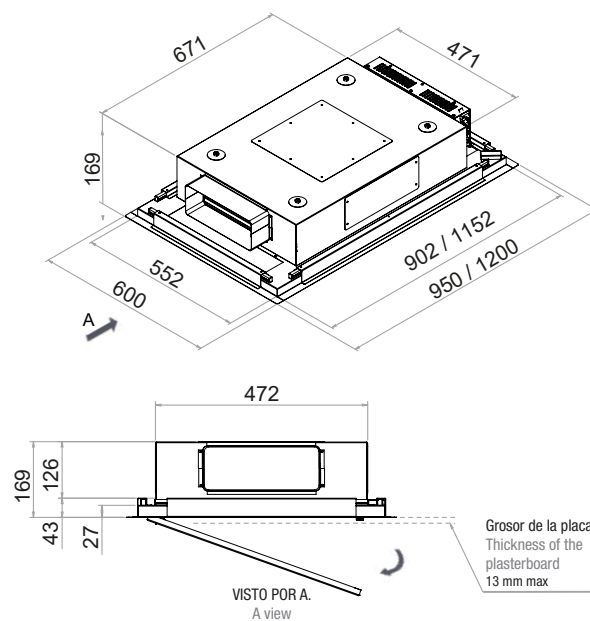

Medidas en / Dimensions in mm

Motor V.1250

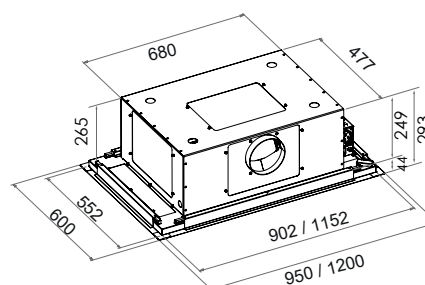

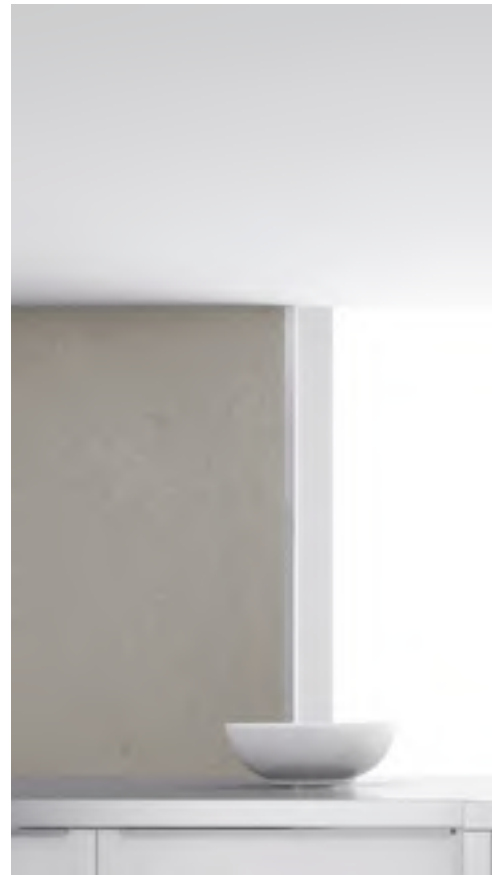
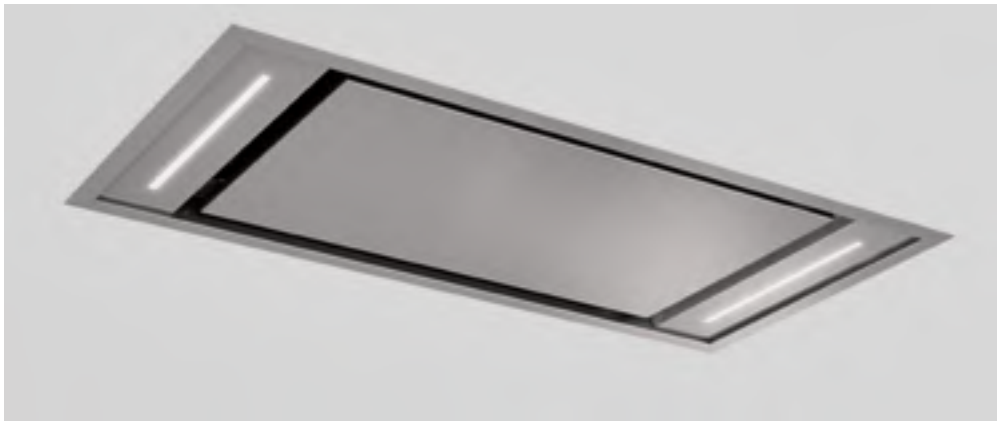
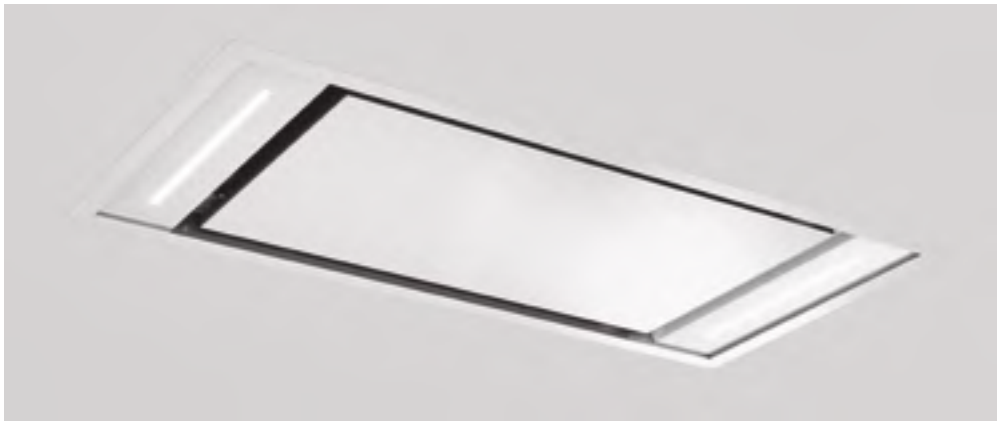

E-295

Inox - Esmaltado epoxi blanco RAL 9016
Stainless Steel - White epoxy enamel RAL 9016

						Opcionales* / Options*	

S.E.C. System®				Inox	Blanco
Motor Interior / Interior Motor				Stainless Steel	White
Front. (cm)	Motor	Ø tubo	Clas. Ener.	Ref.	Ref.
90	V.850	Ø150		009201.A	010329

Motor Interior / Interior Motor				Motor Intermedio exterior / Duct-in-line motor	
Front. (cm)	Motor	Ø tubo	Clas. Ener.	Ref.	Ref.
90	V.1350	Ø150		009964.A	010330

Kits de recirculación / Activated carbon filters kit:

Front. (cm)	Tipo	Ref.
90	FCRL-AE	1202559

Opcionales* / Options*

AirLink

Modelo compatible. No se equipa de serie. Imprescindible solicitar en pedido.
 Compatible Model. Is not included as standard. Must be ordered.

Cambio a LED cálido de 3000K.
 LED change to warm light LED 3000K.

Conjunto botonera INOX de encastre a pared.
 Stainless steel button panel set for embedding into the wall

Conjunto botonera BLANCO de encastre a pared.
 White button panel set for embedding into the wall

(*) Los opcionales se suministrarán junto con la campana. Indicar claramente "OPCIONAL" en el pedido e introducir los datos de forma clara.
 (*) The optionals will be supplied together with the cooker hood. Indicate clearly 'OPTIONAL' in the order and enter the data clearly.

Notas / Notes

Salida de humos de serie: Lateral largo
 Standard fume outlet: long side

Modelo personalizable en cualquier color de la carta RAL. Bajo presupuesto
 Customizable model in any color from the RAL chart. On request



Para otras alturas, consultar con nuestra división técnica.
 For other heights, please check with our Technical department.



Botonera encastre pared
 Button panel set for embedding into the wall



Mando a distancia
 Remote Touch Control
 Ref. 620062200478



E-295



Doble sistema de fácil instalación
Double easy installation System
 Ver pág. 35 / See page 35

Motor Interior / Interior Motor

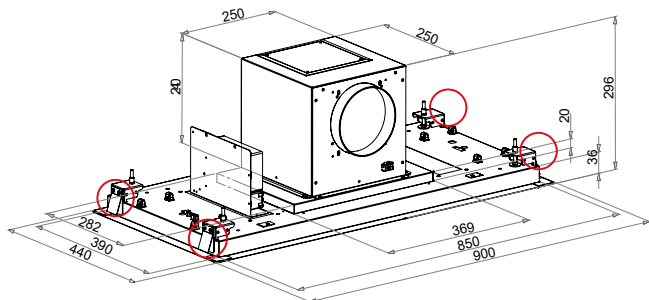

Peso / Weight: 16 kg
 Apertura de puerta
 Door opening

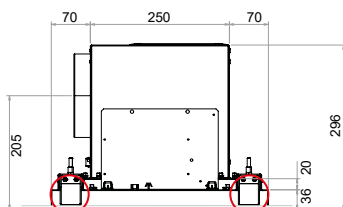

Grosor de la placa
 Thickness of the
 plasterboard
 20 mm max

VISTO POR A.
 A view

Altura mínima falso techo
Minimum height of false ceiling

Motor Int.	305 mm
Motor Ext.	295 mm

Motor Intermedio exterior / Duct-in-line motor

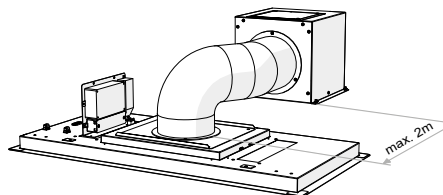
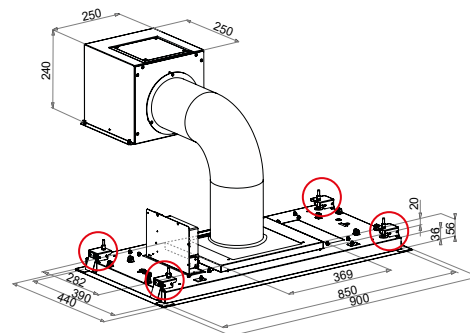

Distancia máxima
 Maximum distance

Medidas Encastre
Built in Sizes

90 cm	860 x 395
90 cm	860 x 395

Peso / Weight: 16 kg
 Apertura de puerta
 Door opening

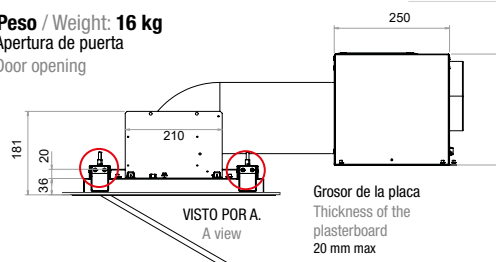

Grosor de la placa
 Thickness of the
 plasterboard
 20 mm max

VISTO POR A.
 A view

Medidas en / Dimensions in mm





E-297

Inox - Cristal blanco o Negro

Stainless Steel - White glass or Black glass

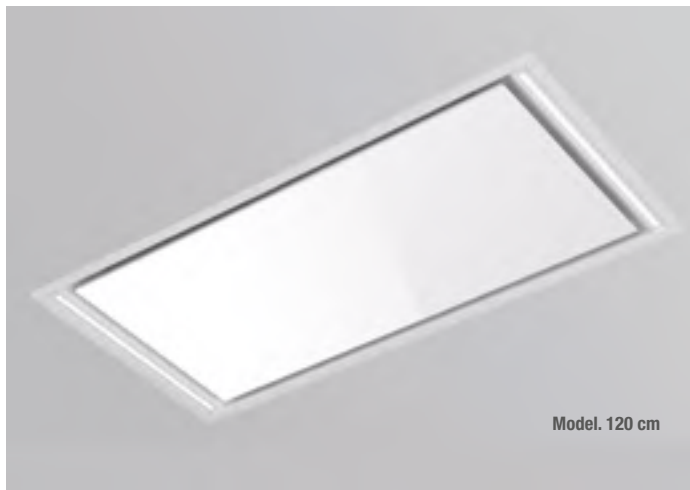

Model. 120 cm



Model. 95 cm

E-297

Inox - Cristal blanco o Negro
Stainless Steel - White glass or Black glass

							Opcionales* / Options*

S.E.C. System®

Motor Interior / Interior Motor

Front. (cm)	Motor	Ø tubo	Clas. Ener.
95	V.1130 eco PLUS	Ø150	A+
95	V.1250 eco	Ø150	A+
120	V.1130 eco PLUS	Ø150	A+
120	V.1250 eco	Ø150	A+

Motor Intermedio exterior / Duct-in-line motor

95	V.1550 eco	Ø150	A+
	V.2450 eco	Ø200	A+
120	V.1550 eco	Ø150	A+
	V.2450 eco	Ø200	A+

Motor exterior a muro / Remote Motor - Wall Outdoor

95	V.1300 eco	Ø150	A+
120	V.1300 eco	Ø150	A+

Motor de tejado / Remote Motor -Roof Outdoor

95	V.2350 eco	Ø200	A+
120	V.2350 eco	Ø200	A+

Kits de recirculación / Activated carbon filters kit:

Front. (cm).	Tipo	Ref.
95,120	FCRL-AE	1202570

Inox
Stainless Steel

Cristal blanco
White glass
RAL 9016

Cristal Negro
Black glass
RAL 9005

Notas / Notes

Caja motor rotativa : La salida de humos puede cambiarse gracias a la caja motor rotativa
 Motor Box rotary : Exit position can be changed thanks to its rotative motor box

Modelo personalizable en cualquier color de la carta RAL. Bajo presupuesto
 Customizable model in any color from the RAL chart. On equest

Para otras alturas, consultar con nuestra división técnica.
 For other heights, please check with our Technical department.



Botonera encastre pared
 Button panel set for embedding into the wall



Mando a distancia
 Remote Touch Control
Ref. 620062200478

Opcionales* / Options*

AirLink

Modelo compatible. No se equipa de serie. Imprescindible solicitar en pedido.
 Compatible Model. Is not included as standard. Must be ordered.

Sistema de filtrado **ECO PLASMA**
ECO PLASMA filter system

Este modelo puede solicitarse bajo pedido SIN ILUMINACIÓN.
 This model can be manufactured WITHOUT LIGHTING on request

Conjunto botonera INOX de encastre a pared.
 Stainless steel button panel set for embedding into the wall

Conjunto botonera BLANCO de encastre a pared.
 White button panel set for embedding into the wall

(*) Los opcionales se suministrarán junto con la campana. Indicar claramente "OPCIONAL" en el pedido e introducir los datos de forma clara.
 (*) The optionals will be supplied together with the cooker hood. Indicate clearly 'OPTIONAL' in the order and enter the data clearly.



Doble sistema de fácil instalación Double easy installation System

Ver pág. 35 / See page 35

Motor Interior / Interior Motor

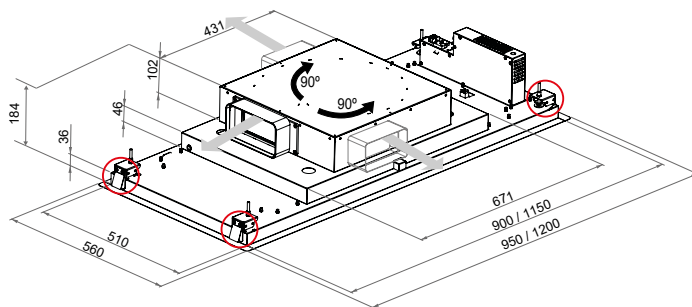

Peso / Weight mod. 95 : 22 kg / Peso / Weight mod. 120 : 27 kg

Apertura de puerta reversible / Reversible door opening

Box rotativo / Rotary Motor Box

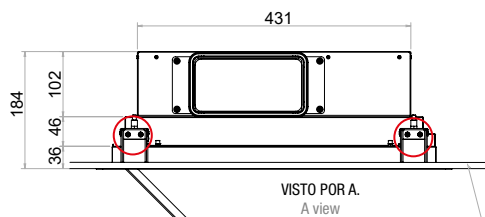

Grosor de la placa
Thickness of the plasterboard
20 mm max

Altura mínima falso techo Minimum height of false ceiling

Motor Int.	190 mm
Motor Int. V.1250	310 mm
Motor Ext. Ø 200	250 mm
Motor Ext. □ 260 x 100	160 mm

Medidas Encastre Built in Sizes

95 cm	910 x 515
120 cm	1160 x 515

INCLUIDO / INCLUDED

Este modelo con motorización V.1130 ECO PLUS incorpora de serie 2 m de tubo de extracción de humos espiral Ø150 circular.

This model with the V.1130 ECO PLUS motor system comes with 2 m of 150 diameter circular spiral extractor flue as standard.

Las unidades con motorizaciones V.2450 Intermedio Exterior y V.2350 Tejado, incorporan de serie 5 m de tubo de extracción de humos SEC System® de Ø203 mm interior y Ø253 mm exterior.

This model with the V.2450 duct-in-line remote motor and V.2350 roof motor system comes with 5 m of S.E.C. fume extractor flue as standard System®, interior Ø 203 mm and exterior Ø 253.

E-297

Motor Intermedio exterior / Duct-in-line motor

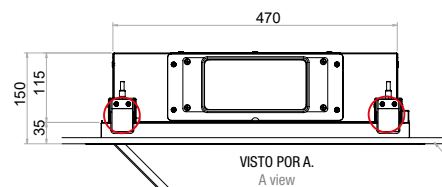
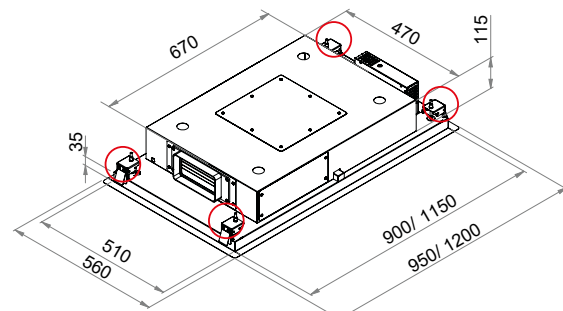

Grosor de la placa
Thickness of the plasterboard
20 mm max

Medidas Encastre Built in Sizes

95 cm	910 x 515
120 cm	1160 x 515



Motor V.1250

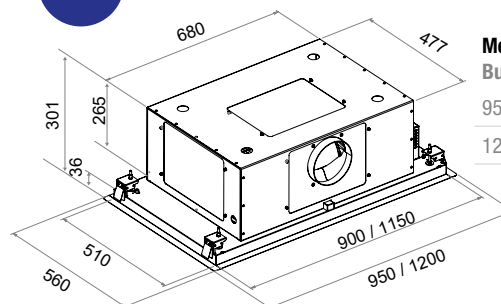

Medidas Encastre Built in Sizes

95 cm	910 x 520
120 cm	1160 x 520

Medidas en / Dimensions in mm

New
Collection



Negro satinado / Black Satin



Blanco / White



Oro / Gold



Cobre / Copper



SKYRING LIGHT

SKYRING / SKYRING LIGHT Policarbonato traslúcido Blanco White translucent Polycarbonate

Opcionales* / Options*



AirLink

SKYRING S.E.C. System® Interior / Interior

Color	Motor	Ø tubo	Clas. Ener.	Ref.
Plata / Silver	V.1130 eco PLUS	Ø150	B	010004
Oro / Gold	V.1130 eco PLUS	Ø150	B	010005
Cobre / Copper	V.1130 eco PLUS	Ø150	B	010006
Blanco / White	V.1130 eco PLUS	Ø150	B	010007
Negro Sat. / Black Satin	V.1130 eco PLUS	Ø150	B	010008

SKYRING Intermedio exterior / Duct-in-line motor

Color	Motor	Ø tubo	Clas. Ener.	Ref.
Plata / Silver	V.1550 eco	Ø150	A	010009
Oro / Gold	V.1550 eco	Ø150	A	010010
Cobre / Copper	V.1550 eco	Ø150	A	010011
Blanco / White	V.1550 eco	Ø150	A	010012
Negro Sat. / Black Satin	V.1550 eco	Ø150	A	010013

SKYRING LIGHT S.E.C. System® Interior / Interior

Color	Motor	Ø tubo	Clas. Ener.	Ref.
Blanco	V.1130 eco PLUS	Ø150	B	010795

SKYRING LIGHT Intermedio exterior / Duct-in-line motor

Color	Motor	Ø tubo	Clas. Ener.	Ref.
Blanco	V.1550 eco	Ø150	A	010796

Opcionales* / Options*

AirLink

Modelo compatible. No se equipa de serie. Imprescindible solicitar en pedido.
Compatible Model. Is not included as standard. Must be ordered.

(*) Los opcionales se suministrarán junto con la campana. Indicar claramente "OPCIONAL" en el pedido e introducir los datos de forma clara.

(*) The optionals will be supplied together with the cooker hood. Indicate clearly 'OPTIONAL' in the order and enter the data clearly.

Kit cables / kit cables

L: 2500 mm 500050400126

L: 4000 mm 500050400127

Kits de recirculación / Activated carbon filters kit:

Front. (cm).	Tipo	Ref.
54	FCRL-AE	1200226



Mando a distancia
Remote Touch Control
Ref. 620062200478



SKYRING / SKYRING LIGHT

Notas / Notes

SKYRING Iluminación circular LED 14W
SKYRING Circular 14W LED Lighting

SKYRING LIGHT Iluminación circular LED 10W
SKYRING LIGHT Circular 10W LED Lighting

Altura estándar del cable 1560 mm.
 Standard Cable length 1560 mm.



Para otras alturas, consultar con nuestra división técnica.
 For other heights, please check with our Technical department.

Zona de cocción recomendada:
 Modular 30-40 cm | Compacta máx. 60 cm

Recommended Cooktop:
 Modular 30-40 cm | Compact: Max 60 cm



**Regulación de medida en falso
 techo de 200 a 300 mm.**
 200-300 mm False Ceiling regulation

Altura mínima falso techo
 Minimum height of false ceiling

Motor Int.	200 mm
Motor Ext.	200 mm

Medidas Encastre
 Built in Sizes

75 cm	Ø510 mm
120 cm	1160 x 515



Medidas en / Dimensions in mm

CAMPANAS INTEGRADAS EN LA PLACA COCCIÓN

COOKER HOODS INTEGRATED INTO INDUCTION COOKTOP

E-395

E-396

p.72



E-320

p.76





E-395
BISELADA
BEVELED



E-395 Biselada
Beveled

E-396 Sobre encimera o encastrada
Built-in or Flushed

Campana integrada en la placa de cocción. Cristal negro
Cooker Hood integrated into induction cooktop. Black glass



eco PLUS



Slider

Last TIME



Filters NANOTEC



Filters ALU



Filters Auto.



AIR Clean 24h



Filters ECO PLASMA



E-395
BISELADA
BEVELED



E-396
ENCASTRADA
FLUSHED

E-396

SOBRE ENCIMERA O ENCASTRADA
BUILT-IN OR FLUSHED



E-395

Biselada
Beveled

E-396

Sobre encimera o encastrada
Built-in or Flushed

Instalación fácil y compatible con
cualquier tipo de muebles
Easy and compatible with
all kind of furniture



E-395 / E-396



eco PLUS



Last TIME

Filters NANOTEC

Filters ALU



AIR Clean 24h

Filters ECO PLASMA

E-395 Cristal biselado / Beveled glass S.E.C. System® Motor Interior / Interior Motor

Motor	Ø tubo	Clas. Ener.	Ref.
Recirculación / Recirculation V.930 eco	Ø150	A+	010851

E-396 Cristal recto / Straight glass S.E.C. System® Motor Interior / Interior Motor

Motor	Ø tubo	Clas. Ener.	Ref.
Recirculación / Recirculation V.930 eco	Ø150	A+	010853

NANOTEC

ALTA EFICIENCIA, LAVABLE Y REACTIVABLE
EFFICIENCY, WASHABLE AND REACTIVABLE

Los filtros Nanotec ofrecen un excelente rendimiento en sistemas de recirculación. Gracias a su innovadora composición, pueden lavarse en lavavajillas y reactivarse en horno, prolongando su vida útil. Incorporan esferas de carbón activado con una densidad de 2200 g/m², optimizando la absorción de olores y alcanzando una eficacia del 75%. Su durabilidad supera los 3 años, dependiendo del uso y mantenimiento.

Nanotec filters offer excellent performance in recirculation systems. Thanks to their innovative composition, they can be cleaned in the dishwasher and reactivated in the oven, extending their useful life. They incorporate activated carbon spheres with a density of 2200 g/m², optimising odour absorption and achieving 75% efficiency. Their durability exceeds 3 years, depending on use and maintenance.

Características de la campana	Features of the cooker hood
Mínima altura interior de la campana 220 mm	Shallow built-under in 220 mm
Motor de bajo consumo y mayor eficiencia.	Eco-efficient low consumption motor
Bajo nivel sonoro: 52 dB min. / 72 dB max.	Lowest Noise levels Mix 52 Db / Max 72 Db
Excelente velocidad de aspiración	Excellent Airflow
Sistema de filtrado NANOTEC	NANOTEC filter system
Conducto rectangular trasero: 220 x 90 mm	Rear 220 x 90 mm rectangular ducting pipe (Extraction version)
Nueva Rejilla. Mejora de la succión	New - Suction area

Características de la placa de inducción	Features of the induction hob
Potencia Total: 7400 W	Total Power: 7400 W
Stop&Go	Stop&Go
Cristal cerámico Keraspectrum	Keraspectrum Glass and E.G.O High Tech inside
Cocción automática	Automatic cooking
La función Bridge permite acoplar 2 inductores de cada lado para hacer un único conjunto	Bridge function allows coupling 2 inductors on each side to make it a unique set
Detección inteligente de ausencia del recipiente	Smart detection of missing pot
La función Chef le permite modificar la posición de la sartén dentro de la placa sin perder la potencia de calor	Chef function. Let you easily move the pan from Inductors .left to right keeping the heating power level
Indicador de calor residual	Residual heat indicator
Función Booster y Doble Booster Acelerador de calor	Booster & Double Booster function Heating accelerator

Notas / Notes

Incluye bandeja de limpieza fácil que recoge el aceite
Includes easy-cleaning tray for collection of oils

Opcionales* / Options*

Sistema de filtrado ECO PLASMA
ECO PLASMA filter system

Kits tubos salida inferior / Pipe kit for bottom outlet:

Descripción Description	Ref.
Codo + 120 cm. de tubo / Bend + 120 cm. duct	010864

Medidas Encastre / Dimensions built in size

Instalación vidrio sobre encimera
Installation "built-in" / "built-on top"

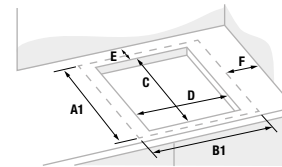

Instalación vidrio enrasado
Installation "flushed"

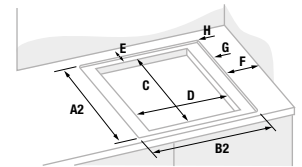

Tamaño del Vidrio Size of glass		Tamaño de Corte Size of cut		Fondo Rear	Lado Lateral	Radio Radio	Instalación en vidrio al ras Installation "flushed"		
A1	B1	C	D	E (min)	F (min)	H	A2	B2	G*
520	780	490	750	50	40	8	524	784	5

* Profundidad/Depth

La medida exterior mínima del mueble para instalar este tipo de campana es de 900 x 560 mm.

The minimal external dimension of furniture to install this hood should be 900 x 560 mm.

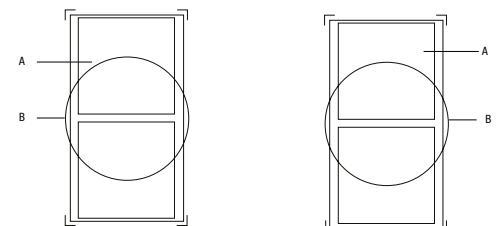
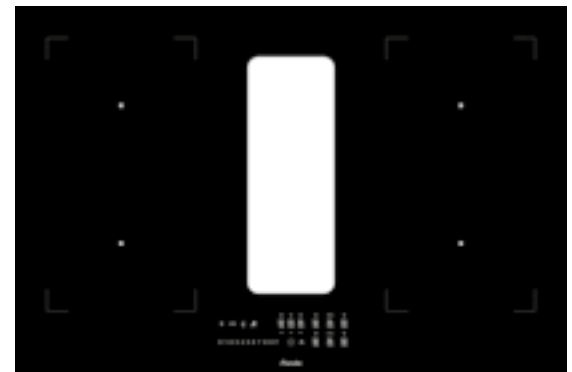

	□ EXT.	□ MÍN.	□ MÁX.	Power W	Booster W	Súper Booster W
A	220 x 180 mm	100 mm	Ø 180 mm	2100w	2600w	3700w
B	220 x 360 mm	135 mm	Ø 220 mm	-	-	-

E-395 / E-396

Vista frontal / Front view

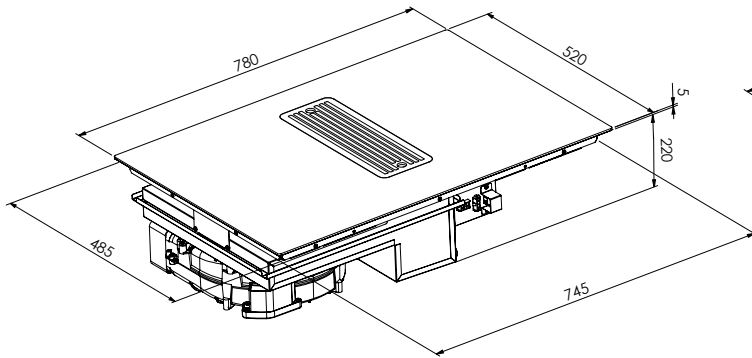

Vista trasera / Rear view

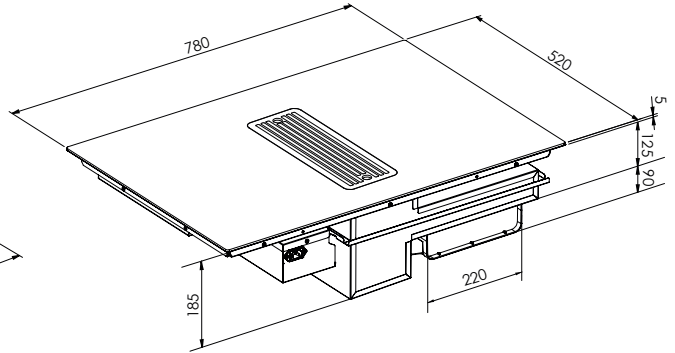

Salida trasera / Rear exit

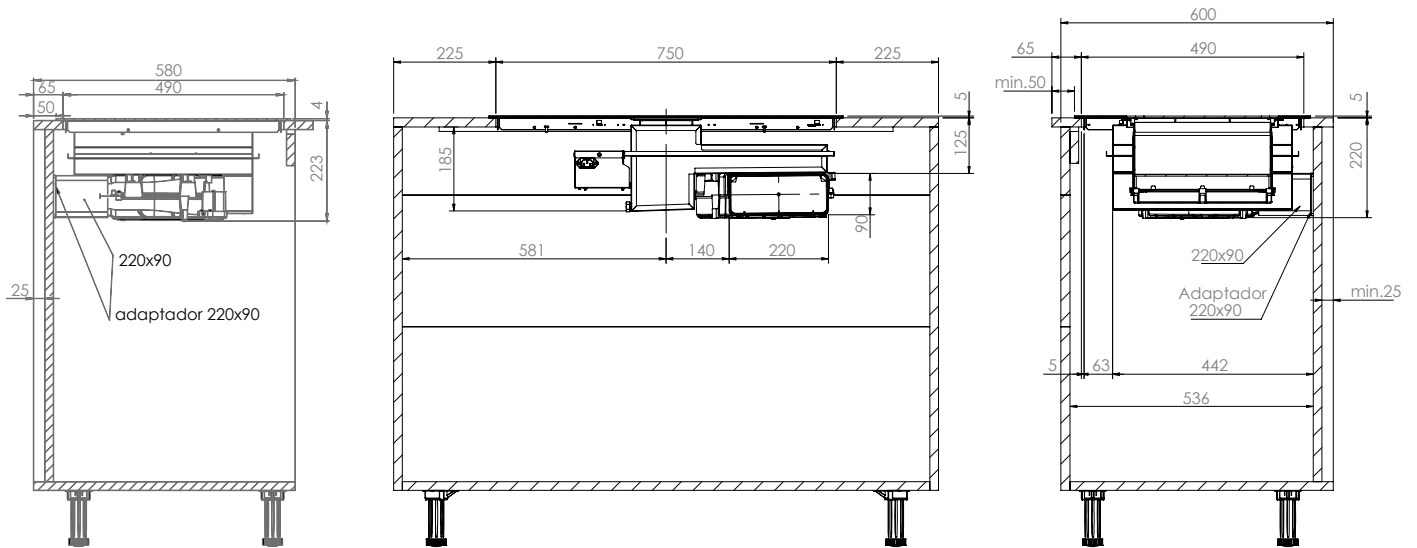

Salida inferior / Bottom outlet

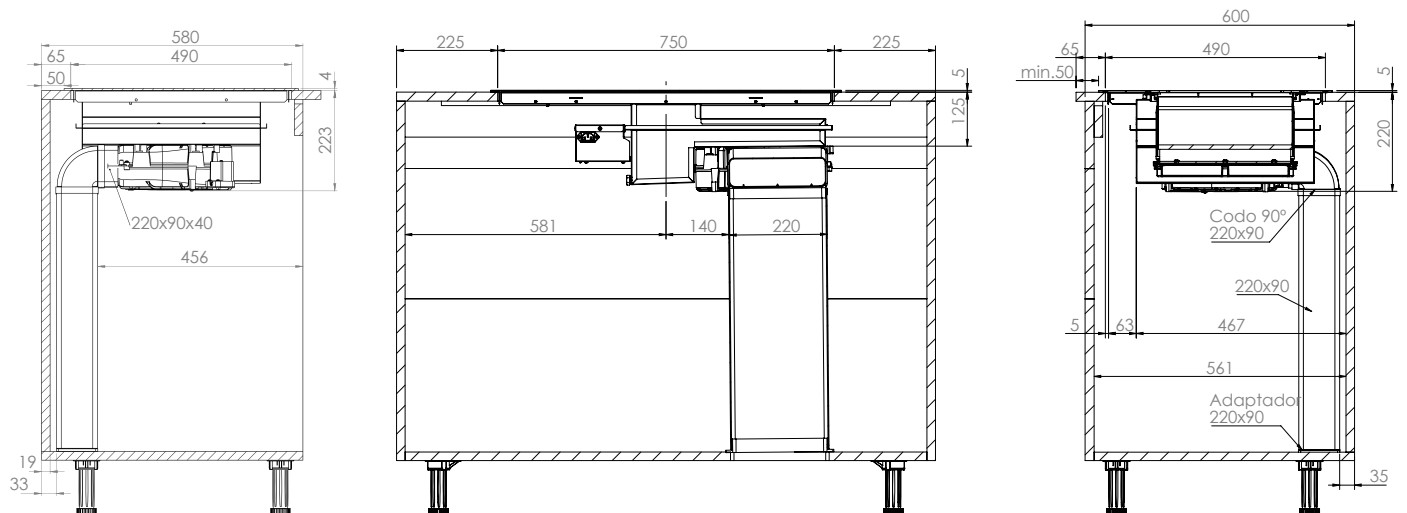

Medidas en / Dimensions in mm

New
Collection



Inox

E-320

Campana de integración a encimera. Inox o frontal en Cristal Negro
Cooker hoods for worktop integration. Stainless Steel or Black Glass

90 / 120
cm



Touch

Cristal / Glass



Elect.

Inox

Last
TIME



Filters
ALU

Opcionales* / Options*



Kits
Recirculation

SAP

Sistema anti atrapamientos Pando
Pando Anti-Trap Safety System

Motor Interior / Motor Intermedio Exterior Interior Motor / Duct-in-line motor

Inox / Stainless steel

Front. (cm)	Motor	Ø tubo	Clas. Ener.	Ref.
90	V.950	Ø150	A	008994
90	V.1200 EXT	Ø150	A	008995
120	V.950	Ø150	A	009783
120	V.2000 EXT	Ø200	A	009784

Cristal Negro / Black Glass

Front. (cm)	Motor	Ø tubo	Clas. Ener.	Ref.
90	V.950	Ø150	A	008998
90	V.1200 EXT	Ø150	A	008999
120	V.950	Ø150	A	009786
120	V.2000 EXT	Ø200	A	009787

Kits de recirculación / Activated carbon filters kit:

Front. (cm).	Acabado Finished	Tipo	Ref.
90	Inox	FCRL-AE	1202673
120	Inox	FCRL-AE	1202674

Notas / Notes

Notas para instalación con placa inducción Notes for installation with an induction hob

Medida de 90 cm sólo para encimeras de 81 x 38 cm.
90 cm Size only for 81 x 38 cm hobs.

Medida de 120 cm sólo para encimeras de 105 x 38 cm.
120 cm Size only for 105 x 38 cm hobs.

Sólo recomendable en zonas de cocción compactas, no modulares.
Only recommended for non-modular hobs.

Distancia máxima entre campana y zona de cocción de 50 mm.
Maximum distance between hood and hob 50 mm.



E-320

Motor Interior / Interior Motor

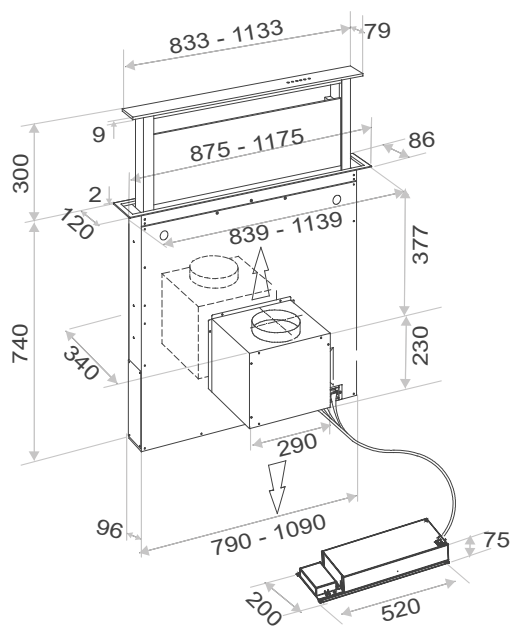

Medidas Encastre
Built in Sizes

90 cm 100 x 842

120 cm 100 x 1142

Motor Intermedio exterior / Duct-in-line motor

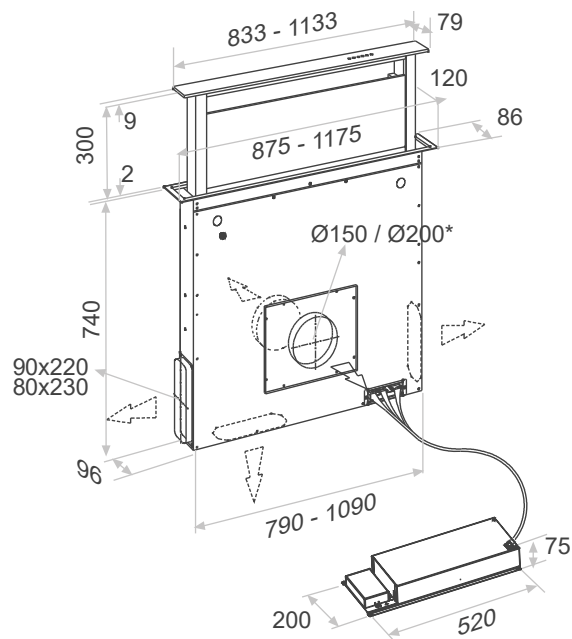

Medidas en / Dimensions in mm

**CAMPANAS DE
INTEGRACIÓN
A MUEBLE**

**COOKER HOODS
INTEGRATED
INTO CABINET**



GRM
p.81



EVO
p.82

GTI
p.84

PRO
p.86

NCR
p.88

NEO
p.90

GRV
p.91

GRX
p.92

TIL-2
p.94



TIB-2
p.96

TIM-2
p.98

TIX
p.100

GIM 2
p.102

**BGF SEC
System**
p.104

PGF
p.105

**IES SEC
System**
p.106

**IES SEC
System
Touch**
p.107

ES
p.108

GR20
p.109

GR05
p.109

ESTRUCTURA EVOLIKE

Estructura para Grupo Filtrante de pared o isla
Structure for wall or island for Filtering Sets

Disponible para los modelos / Available for models

**EVO / PRO / GTI / NCR / NEO
GRV / BGF SEC SYSTEM®**

Dimensione y decore su EVOLIKE Size and decorate your EVOLIKE

Puede panelarse con multitud de materiales: madera, cristal, espejo, solid surface, losa cerámica, acero inoxidable, ...
You can choose from a wide range of materials: wood, glass, mirrored, solid surface, ceramic tile, stainless steel and more.

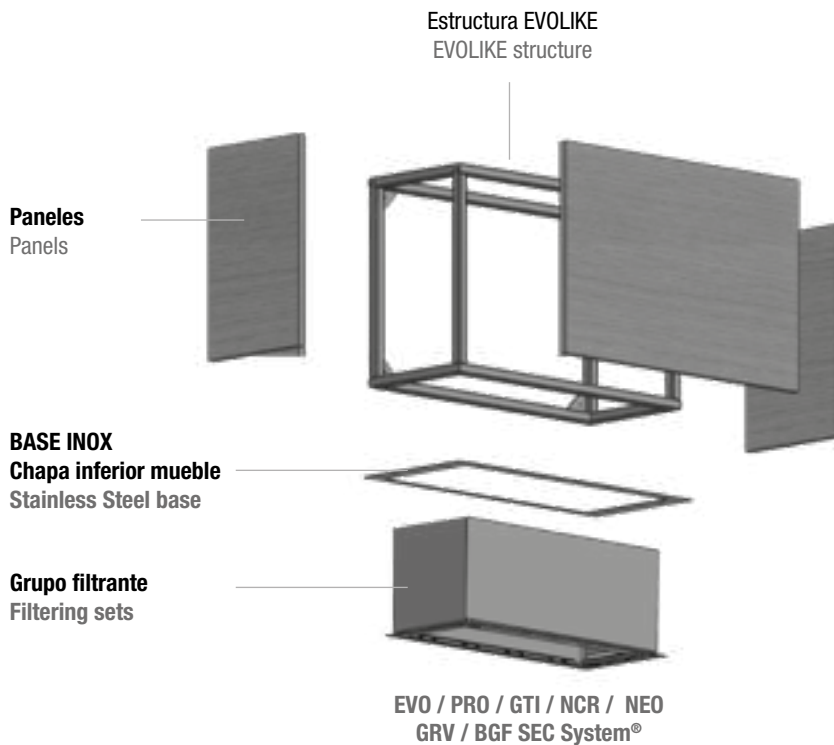

Dimensiones por modelos (mm)
Dimensions by models (mm)

	A	B	C
EVO 58	670	330	425
EVO 78	870		
EVO 94,8	1035		
EVO 111,6	1200		
EVO 128,5	1375		
PRO-520	570	345	425
PRO-850	915		
PRO-1000	1050		
NEO-520	570	345	425
NEO-780	830		
NCR-520	570		
NCR-780	830	345	425
NCR-1110	1160		
GTI-510	575		
GTI-725	790	330	425
GTI-810	875		
GTI-1110	1175		
GTI-1280	1345		
GRV-520	570		
GRV-780	830	345	425
BGF-500	575		
BGF-750	825	515	425
BGF-990	1065		
BGF-1240	1315		

Bajo presupuesto / On request

Este producto se suministra conjuntamente con el grupo filtrante. (Nunca se venderá solo la estructura).
This product is delivered together along with its Filtering Sets. (The structure is never sold on its own).

Dependiendo de las medidas de la estructura, se puede suministrar con el grupo filtrante S.E.C. System.
Can be supplied with the S.E.C. System filter set depending on the size of the structure.

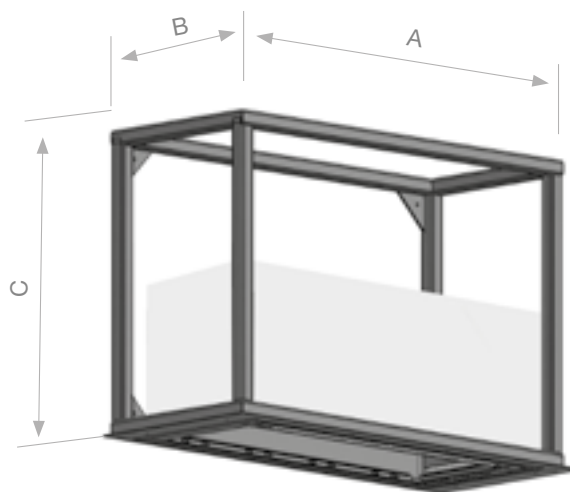

New
Collection



GRM

Sus dimensiones lo hacen muy versátil pudiendo ser instalado en muebles de 30 ó 35 cm. de profundidad
Its dimensions make it very versatile and it can be installed in furniture of 30 or 35 cm. deep.

Inox
Stainless Steel

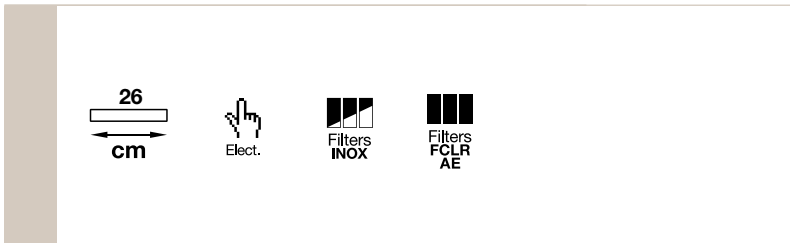

S.E.C. System® Motor Interior / Interior Motor

Front. (cm)	Motor	Ø tubo	Clas. Ener.	Ref.
26	V.730	Ø120	A	010680

Notas* / Notes*

Filtro de Carbón Activado (FCLR-AE) incorporado de serie
Activated Carbon Filter (FCLR-AE) fitted as standard.

Botonera electrónica de una velocidad
Single-speed electronic pushbutton panel

Integración a mueble alto a partir de 30 cm. de profundidad
Integrated into wall units from 30 cm depth onwards

Ejemplo de colocación en mueble alto Example of location in the furniture

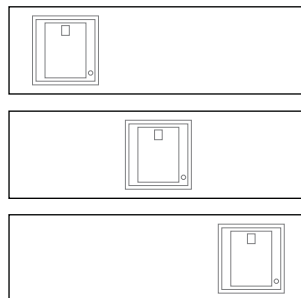

Ancho del módulo: 30, 60, 90, 100 y 120 cm.
Module width: 30, 60, 90, 90, 100 and 120 cm.

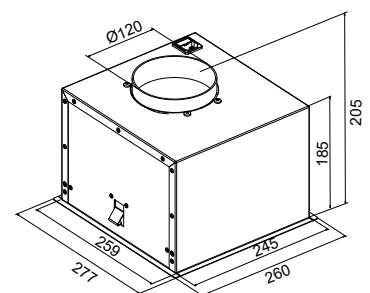

Medidas en / Dimensions in mm

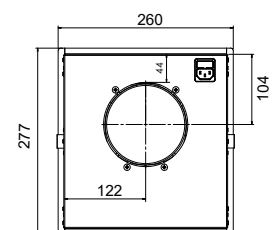

Medidas encastre Built in Sizes

26 255 x 270



Model. 78 cm

GRUPO EVO

Inox
Stainless Steel

Compatible con EVOLIKE
EVOLIKE compatible

58 / 78 / 94,8
111,6 / 128,5

cm



SEC
System
PLUS



eco



SIA
Safety

Last
TIME



AIR
Clean
5h



Opcionales* / Options*



AirLink



S.E.C. System® Motor Interior / Interior Motor

Front. (cm)	Motor	Ø tubo	Clas. Ener.	Ref.
58	V.750	Ø125	B	008496
	V.850	Ø150	A+	007792
	V.1050 eco SEC® PLUS	Ø150	A++	009615
78	V.750	Ø125	B	008498
	V.850	Ø150	A+	007379
	V.1050 eco SEC® PLUS	Ø150	A++	009616
94,8	V.1250 eco	Ø150	A++	008499
	V.750	Ø125	B	008500
	V.850	Ø150	A+	007796
	V.1050 eco SEC® PLUS	Ø150	A++	009618
111,6	V.1250 eco	Ø150	A++	008501
	V.850	Ø150	A+	007800
	V.1050 eco SEC® PLUS	Ø150	A+	009620
	V.1250 eco	Ø150	A+++	008502
128,5	V.850	Ø150	A+	007804
	V.1050 eco SEC® PLUS	Ø150	A++	009622
	V.1250 eco	Ø150	A+++	008503

Motor Intermedio exterior / Duct-in-line motor

Front. (cm)	Acabado Finished	Tipo	Ref.
78	V.1550 eco	Ø150 A+	009617
94,8	V.1550 eco	Ø150 A+	009619
111,6	V.1550 eco	Ø150 A+	009621
128,5	V.1550 eco	Ø150 A+	009623

Kits de recirculación / Activated carbon filters kit:

Front. (cm)	Acabado Finished	Tipo	Ref.
58	INOX	FCRL-AE	1200165
78	INOX	FCRL-AE	1200171
94,8	INOX	FCRL-AE	1202513
111,6	INOX	FCRL-AE	1200179
128,5	INOX	FCRL-AE	1202532

Distribución filtros y luces por medidas.

Distribution of filters and lights according the size of the hood.

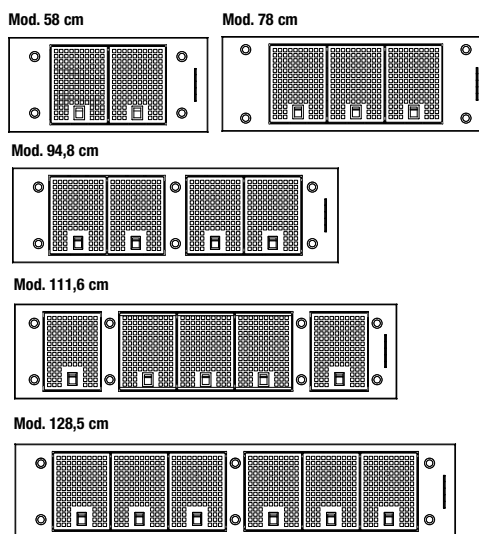

Opcionales* / Options*

AirLink

Modelo compatible. No se equipa de serie. Imprescindible solicitar en pedido.
Compatible Model. Is not included as standard. Must be ordered.

Sistema de filtrado **ECO PLASMA**
ECO PLASMA filter system

Cambio a LED cálido de 3000K.
LED change to warm light LED 3000K.

Mando a distancia Touch. Suministrado con la campana.
Remote Control Touch supplied together with the hood.

Opción de salida trasera. Indicar en pedido.
Option of rear exit, has to be mentioned in the order.

Base Inox para GRUPO Filtrante.
Stainless Steel base for filtering SET,

Para otras motorizaciones, consultar
For other motor options please check

(*) Los opcionales se suministrarán junto con la campana. Indicar claramente "OPCION-AL" en el pedido e introducir los datos de forma clara.

(*) The optionals will be supplied together with the cooker hood. Indicate clearly 'OPTIONAL' in the order and enter the data clearly.



EVO 58 cm

Base INOX EVO. Stainless Steel base for EVO

* Cualquier variación sobre las medidas indicadas,
bajo presupuesto.

* Any variation to the above sizes, on request.

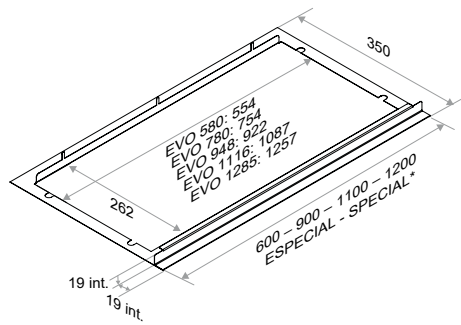

Descripción / Description	Ref.
Base INOX EVO 580	009136
Base INOX EVO 780	009137
Base INOX EVO 948	009985
Base INOX EVO 1116	009986
Base INOX EVO 1285	009989



Mando a distancia
Remote Touch Control
Ref. 620062200478

GRUPO EVO

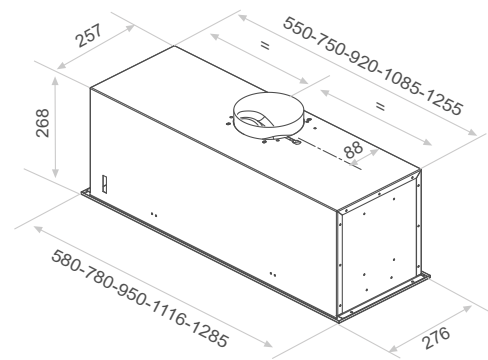

Medidas en / Dimensions in mm

Medidas de encastre Built in Sizes

58	262 x 552
78	262 x 752
95	262 x 922
111,6	262 x 1087
128,5	262 x 1257



Model. Negro / Black (81 cm)

GTI

Inox - Negro - Total Black
Stainless Steel - Black - Total Black

Compatible con EVOLIKE
EVOLIKE compatible

51 / 72,5 / 81 111 / 128 cm	SEC System PLUS	eco	Elect.	Last TIME	AIR Clean 5h	Pando Wi-Fi	Opcionales* / Options*
Filters ALU	Filters Auto.	SIA Safety	GAS 65 cm	IND 55-65 cm	Pando LED	Kits Recirculation	AirLink
						Touch	Filters ECO PLASMA

S.E.C. System® Motor Interior / Interior Motor

Inox
Stainless Steel

Negro
Black

Front. (cm)	Motor	Ø tubo	Clas. Ener.
51	V.750	Ø125	B
	V.1050 eco SEC® PLUS	Ø150	A++
72,5	V.750	Ø125	B
	V.850	Ø150	A+
	V.1050 eco SEC® PLUS	Ø150	A++
81	V.1250 eco	Ø150	A++
	V.850	Ø150	A+
	V.1050 eco SEC® PLUS	Ø150	A++
	V.1250 eco	Ø150	A++
111	V.850	Ø150	A+
	V.1050 eco SEC® PLUS	Ø150	A++
	V.1250 eco	Ø150	A++
128	V.850	Ø150	A+
	V.1250 eco	Ø150	A++

Motor Intermedio exterior / Duct-in-line motor

72,5	V.1550 eco	Ø150	A+
81	V.1550 eco	Ø150	A+

Kits de recirculación / Activated carbon filters kit:

Front. (cm).	Tipo	Ref.
51	FCRL-AE	1202657
72,5	FCRL-AE	1202658
81	FCRL-AE	1202659
111	FCRL-AE	1202660
128	FCRL-AE	1202661

Notas / Notes

AirClean

Sistema automático de funcionamiento del motor 10 min. cada hora durante 5 horas.

Automatic working motor system for 10 minutes every hour during 5 hours.



Mando a distancia
Remote Touch Control
Ref. 620062200478

Opcionales* / Options*

AirLink

Modelo compatible. No se equipa de serie. Imprescindible solicitar en pedido.
Compatible Model. Is not included as standard. Must be ordered.

Sistema de filtrado **ECO PLASMA**
ECO PLASMA filter system

Mando a distancia Touch. Suministrado con la campana.
Remote Control Touch supplied together with the hood.

(*) Los opcionales se suministrarán junto con la campana. Indicar claramente "OPCIONAL" en el pedido e introducir los datos de forma clara.

(*) The optionals will be supplied together with the cooker hood. Indicate clearly 'OPTIONAL' in the order and enter the data clearly.



Model. Inox (81 cm)

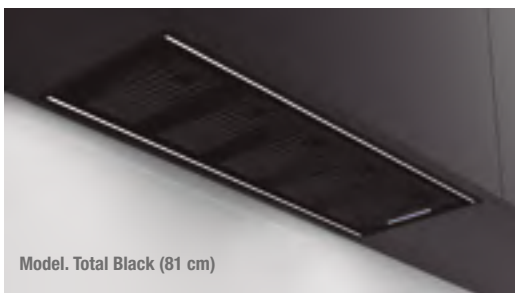

Model. Total Black (81 cm)

Filtros tintados en Negro - Black tinted filters

Front. (cm)	Filtros por grupo filtrante Filters by filter group
51	3 Unidades / 3 Units
72,5	5 Unidades / 5 Units
81	5 Unidades / 5 Units
111	6 Unidades / 6 Units
128	7 Unidades / 6 Units

(*) Incremento de precio sobre el P.V.R del Grupo Filtrante correspondiente
Price increase over the P.V.R of the corresponding Filtering Group

Base INOX GTI Stainless Steel base for GTI

* Cualquier variación sobre las medidas indicadas, bajo presupuesto.

* Any variation to the above sizes, on request.

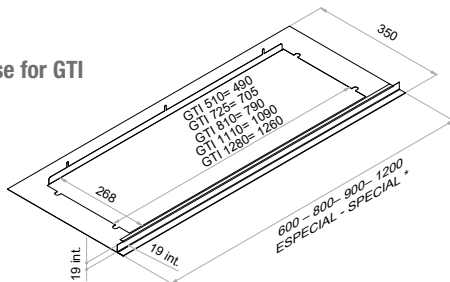

Base	Ref.	Base	Ref.
INOX/S.S. GTI 510	010203	NEGRA/BLACK GTI 510	010226
INOX/S.S. GTI 725	010204	NEGRA/BLACK GTI 725	010227
INOX/S.S. GTI 810	010205	NEGRA/BLACK GTI 810	010228
INOX/S.S. GTI 1.110	010206	NEGRA/BLACK GTI 1.110	010229
INOX/S.S. GTI 1.280	010207	NEGRA/BLACK GTI 1.280	010230

Distribución filtros y luces por medidas. Distribution of filters and lights according the size of the hood.

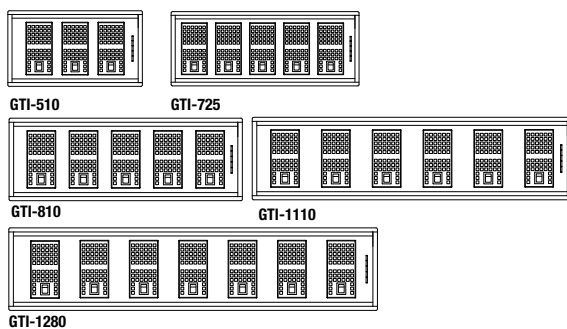

GTI

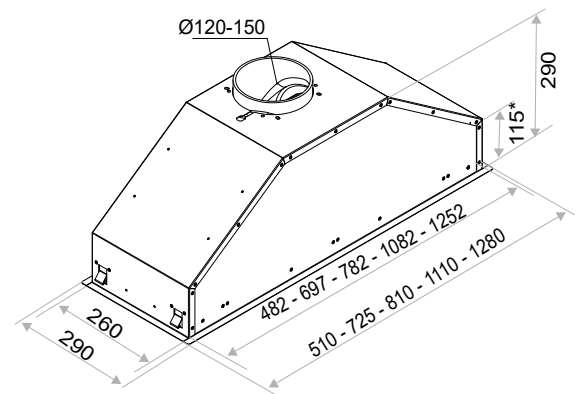

(*) 120mm. para medida de grupo 1280

Medidas en / Dimensions in mm

Medidas de encastre Built in Sizes

510	490 x 265
725	705 x 265
810	790 x 265
1110	1090 x 268
1280	1260 x 268



PRO

Inox
Stainless Steel

Compatible con EVOLIKE
EVOLIKE compatible

<p>52 / 85 / 100 cm</p>	<p>SEC System PLUS</p>	<p>Inox AISI 304</p>	<p>Elect.</p>	<p>Last TIME</p>	<p>Pando Wi-Fi</p>	<p>Opcionales* / Options*</p> <p>Kits Recirculation</p> <p>AirLink</p>
<p>AIR Clean 5h</p>	<p>Pando LED</p>	<p>Filters PRO</p>	<p>SIA Safety</p>	<p>GAS 65 cm</p>	<p>IND 55-65 cm</p>	<p>Touch</p> <p>Filters ECO PLASMA</p>

S.E.C. System®

Motor Interior / Interior Motor

Front. (cm)	Motor	Ø tubo	Clas. Ener.	Ref.
52	V.850	Ø150	A+	009726
	V.1050 eco SEC® PLUS	Ø150	A+	010026
85	V.850	Ø150	A+	009727
	V.1050 eco SEC® PLUS	Ø150	A+	010027
	V.1250 eco	Ø150	A++	010078
100	V.850	Ø150	A+	009831
	V.1050 eco SEC® PLUS	Ø150	A+	010077
	V.1250 eco	Ø150	A++	010079

Opcionales* / Options*

AirLink

Modelo compatible. No se equipa de serie. Imprescindible solicitar en pedido.
Compatible Model. Is not included as standard. Must be ordered.

Sistema de filtrado ECO PLASMA ECO PLASMA filter system

Mando a distancia Touch. Suministrado con la campana.
Remote Control Touch supplied together with the hood.

(*) Los opcionales se suministrarán junto con la campana. Indicar claramente "OPCIONAL" en el pedido e introducir los datos de forma clara.

(*) The optionals will be supplied together with the cooker hood. Indicate clearly 'OPTIONAL' in the order and enter the data clearly.

Kits de recirculación / Activated carbon filters kit:

Front. (cm).	Acabado Finished	Tipo	Ref.
52	INOX	FCRL-AE	1202566
85	INOX	FCRL-AE	1202567
100	INOX	FCRL-AE	1202577



1 **Filtros profesionales:** su forma estilo laberinto permite el paso del aire a la vez que ayuda a condensar las partículas de grasa, liberando al motor de estas suciedades lo que permite que trabaje con menos desgaste y consigue un aumento de la vida útil del mismo. Su fabricación en acero inoxidable de primera calidad hace que sea prácticamente impenetrable para la grasa y le proporciona una durabilidad ilimitada. Los filtros pueden limpiarse fácilmente incluso en lavavajillas, manteniéndose siempre como nuevos.

Professional filters: their maze-type design allows air to pass through while helping to condense grease particles, keeping this dirt out of the motor and so reducing wear and tear and prolonging the working life of the motor. The fact that it is made of top-quality stainless steel means it is practically impenetrable by grease and gives it unlimited durability.

2 **Bandeja recoge-grasas:** recoge las grasas filtradas permitiendo una fácil limpieza y mantenimiento de la campana extractora, a la vez que impide cualquier posible goteo en la zona de cocción. La bandeja es desmontable para su perfecto mantenimiento.

Grease tray: includes a removable tray to pick up any drops of grease that might have accumulated in the hood to ensure easy a cleaning and maintenance.

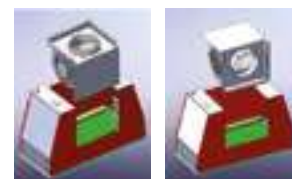

3 **Salida de humos adaptable:** El tubo de salida de humos puede ser vertical o por la parte trasera, facilitando la adaptación a diferentes proyectos sin tener que cambiar de grupo filtrante. Esta acción la puede realizar fácilmente el instalador.

Adaptable fume outlet: The fume outlet flue can be vertical or through the back, making it easier to adapt for different projects without having to change the filter unit. This can be done easily by the installer.



PRO

Notas / Notes

El motor V.1050 no puede incorporar filtros de carbón
 V.1050eco motor cannot incorporate Carbon Filters

Incorpora bandeja de fácil limpieza que recoge las grasas de la cocción de los filtros.
 Includes easy-cleaning tray for collection of oils.

Salida de humos superior o trasera
 Top of back fume outlet

**Base INOX PRO
 Stainless Steel base for PRO**

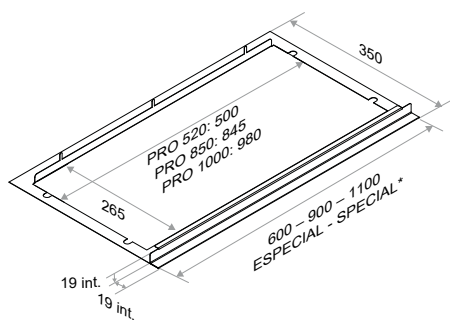

Mando a distancia
 Remote Touch Control
 Ref. 620062200478

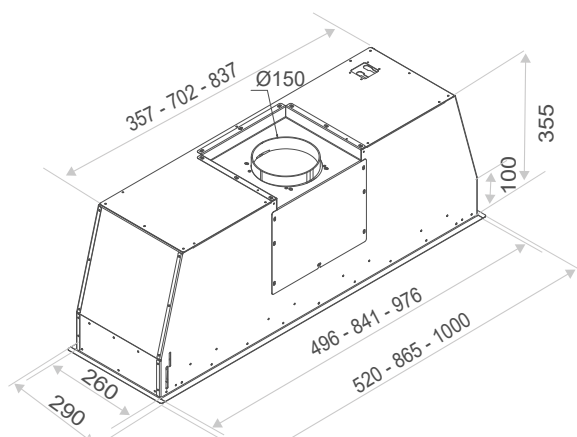

Medidas en / Dimensions in mm

**Dimensiones de emcastre
 Built in Sizes**

52	265 x 501
85	265 x 846
100	265 x 981

Descripción / Description	Ref.
Base INOX PRO 520	9823
Base INOX PRO 850	9824
Base INOX PRO 1000	9987

* Cualquier variación sobre las medidas indicadas, bajo presupuesto.
 * Any variation to the above sizes, on request.



NCR

Inox - Cristal negro o blanco
Stainless Steel - Black or white glass

Compatible con EVOLIKE
EVOLIKE compatible

					<p>Opcionales* / Options*</p>	

S.E.C. System® Motor Interior / Interior Motor

Front. (cm)	Motor	Ø tubo	Clas. Ener.	Ref.
Cristal blanco - White Glass				
52	V.850	Ø150	A	009131
78	V.850	Ø150	A	009132
111	V.850	Ø150	A	009169
Cristal negro - Black Glass				
52	V.850	Ø150	A	010044
78	V.850	Ø150	A	010045
111	V.850	Ø150	A	010062

Kits de recirculación / Activated carbon filters kit:

Front. (cm).	Acabado Finished	Tipo	Ref
52	INOX	FCRL-AE	1202611
78	INOX	FCRL-AE	1202612
111	INOX	FCRL-AE	1202539

Opcionales* / Options*

AirLink

Modelo compatible. No se equipa de serie. Imprescindible solicitar en pedido.
Compatible Model. Is not included as standard. Must be ordered.

Sistema de filtrado ECO PLASMA ECO PLASMA filter system

Mando a distancia Touch. Suministrado con la campana.
Remote Control Touch supplied together with the hood.

Cambio LED original a LED cálido de 3000K.
LED change to warm light LED 3000K.

(* Los opcionales se suministrarán junto con la campana. Indicar claramente "OPCIONAL" en el pedido e introducir los datos de forma clara.

(* The optionals will be supplied together with the cooker hood. Indicate clearly 'OPTIONAL' in the order and enter the data clearly.



Mando a distancia
Remote Touch Control
Ref. 620062200478



Model. 78 cm

NCR

Base INOX NCR
Stainless Steel base for NCR

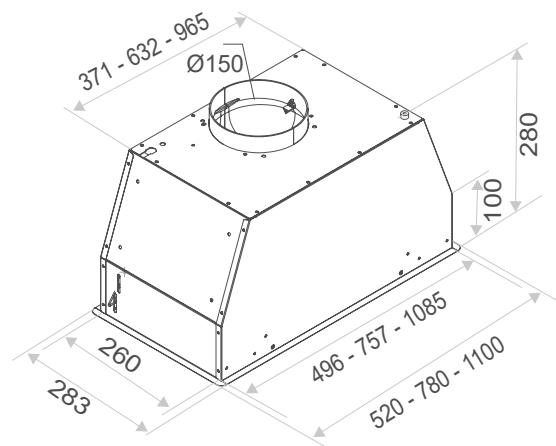
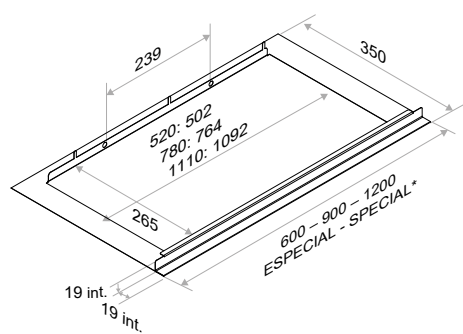

Medidas en / Dimensions in mm

Medidas de encastre
Built in Sizes

52	265 x 502
78	265 x 764
111	265 x 1092

Descripción / Description	Ref.
Base INOX NCR 520	9138
Base INOX NCR 780	9139
Base INOX NCR 1110	10080

* Cualquier variación sobre las medidas indicadas, bajo presupuesto.

* Any variation to the above sizes, on request.

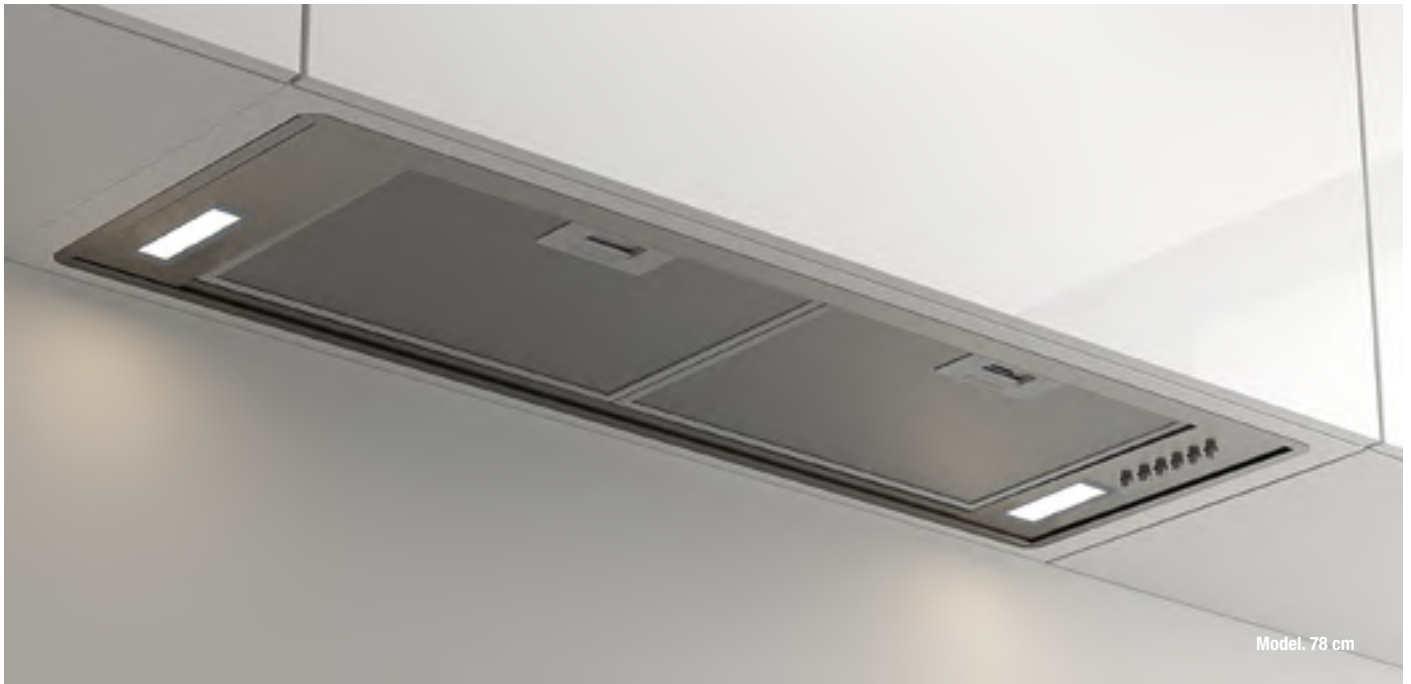

NEO

Inox
Stainless Steel

Compatible con EVOLIKE
EVOLIKE compatible

				Opcionales* / Options*		

S.E.C. System®

Motor Interior / Interior Motor

Front. (cm)	Motor	Ø tubo	Clas. Ener.	Ref.
52	V.830	Ø150/120	A	010702
78	V.830	Ø150/120	A	010703

Opcionales* / Options*

Filtro inoxidable. Precio unitario
Stainless steel filter. Unit price

Opción de cambio a LED de luz cálida de 3000K.
LED change to warm light LED 3000K. .

(*) Los opcionales se suministrarán junto con la campana. Indicar claramente "OPCIONAL" en el pedido e introducir los datos de forma clara.

(*) The optionals will be supplied together with the cooker hood. Indicate clearly 'OPTIONAL' in the order and enter the data clearly.

Kits de recirculación / Activated carbon filters kit:

Front. (cm).	Tipo	Ref
52	FCRL-AE	1202609
78	FCRL-AE	1202610

Medidas Encastre Built in Sizes

52	265 x 502
78	265 x 764

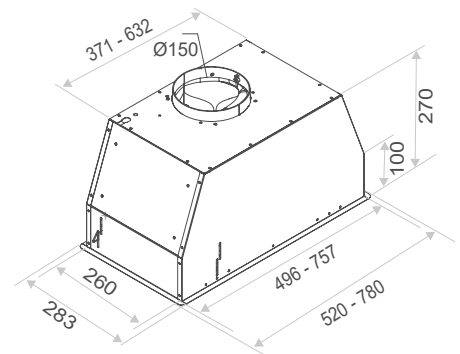

Incluye Aro reductor de serie
Includes reducer ring as standard
Ø150 a Ø120 mm

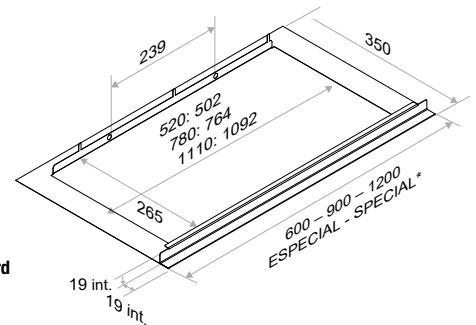

Base INOX NEO Stainless Steel base for NEO

Descripción / Description	Ref.
Base INOX NEO 520	9138
Base INOX NEO 782	9139

* Cualquier variación sobre las medidas indicadas, bajo presupuesto.
* Any variation to the above sizes, on request.



Model. 78 cm

GRV

Inox
Stainless Steel

Compatible con EVOLIKE
EVOLIKE compatible

52 / 78
cm



Touch

Last
TIME



Filters
INOX

LED
4200K

SIA
Safety

GAS
65 cm

IND
55-65cm

Opcionales* / Options*



Kits
Recirculation

LED
3000K

S.E.C. System® Motor Interior / Interior Motor

Front. (cm)	Motor	Ø tubo	Clas. Ener.	Ref.
52	V.850	Ø150	A	010002
78	V.850	Ø150	A	010003

Opcionales* / Options*

Cambio LED original a LED cálido de 3200K.
LED change to warm light LED 3200K.

(*) Los opcionales se suministrarán junto con la campana. Indicar claramente "OPCIONAL" en el pedido e introducir los datos de forma clara.
(* The optionals will be supplied together with the cooker hood. Indicate clearly "OPTIONAL" in the order and enter the data clearly.

Kits de recirculación / Activated carbon filters kit:

Front. (cm)	Tipo	Ref
52	FCRL-AE	1200224
78	FCRL-AE	1200225

Base INOX GRV Stainless Steel base for GRV

Descripción / Description	Ref.
Base INOX GRV 520	010118
Base INOX GRV 780	010119

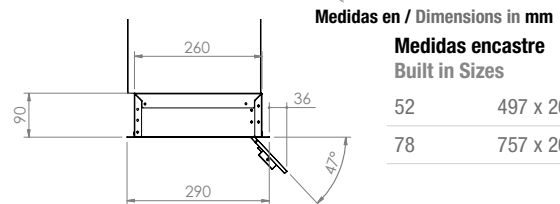
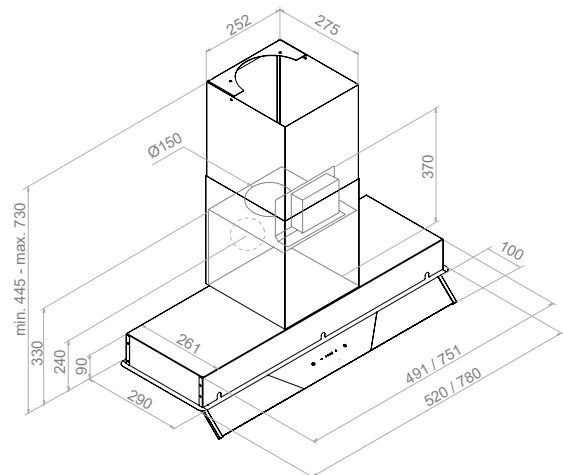
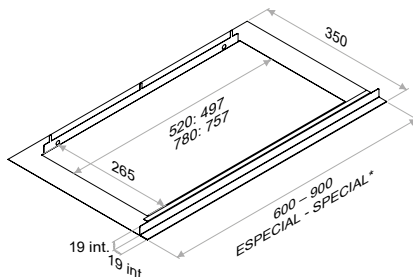

Medidas encastre
Built in Sizes

52	497 x 265
78	757 x 265

* Cualquier variación sobre las medidas indicadas, bajo presupuesto.
* Any variation to the above sizes, on request.



GRX

Box motor direccional que permite salida de humos lateral o vertical
Rotating motor box allowing lateral or vertical smoke outlet

Inox - Blanco - Negro
Stainless Steel - White - Black

						Opcionales* / Options*

S.E.C. System® Motor Interior / Interior Motor

Front. (cm)	Motor	Ø tubo	Clas. Ener.
56	V.850	Ø150	B
56	V.1050 SEC® PLUS	Ø150	A
86	V.850	Ø150	B
86	V.1050 SEC® PLUS	Ø150	A

Inox
Stainless Steel

Blanco
White

Negro
Black

Kits de recirculación Activated carbon filters kit:

Front. (cm).	Tipo	Ref
56	FCRL-AE	1202680
86	FCRL-AE	1202681

Opcionales* / Options*

AirLink

Modelo compatible. No se equipa de serie. Imprescindible solicitar en pedido.
Compatible Model. Is not included as standard. Must be ordered.

Sistema de filtrado **ECO PLASMA**
ECO PLASMA filter system

(*) Los opcionales se suministrarán junto con la campana. Indicar claramente "OPCIONAL" en el pedido e introducir los datos de forma clara.

(*) The optionals will be supplied together with the cooker hood. Indicate clearly 'OPTIONAL' in the order and enter the data clearly.

Notas / Notes

Para un correcto funcionamiento, el tamaño de la zona de cocción deberá ser similar o igual al tamaño de la unidad de filtrado.

For correct operation, the size of the cooking zone must be similar or equal to the size of the filter unit.



Mando a distancia de serie
Remote Touch Control as standart
Ref. 620062200478



Model. 90 cm

GRX

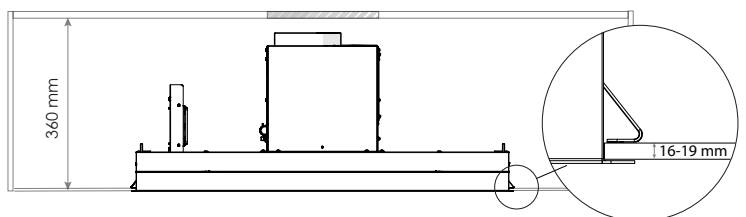
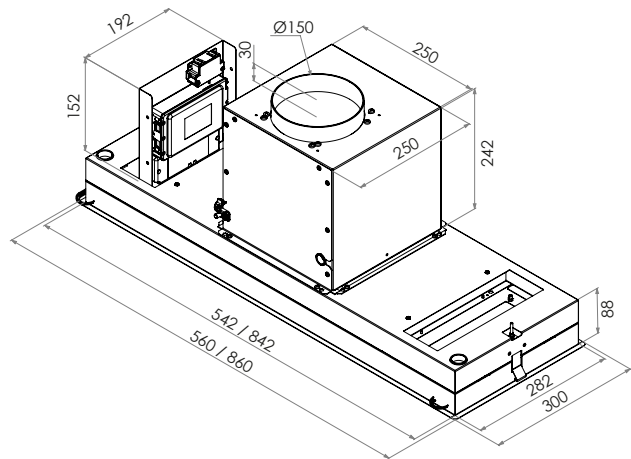
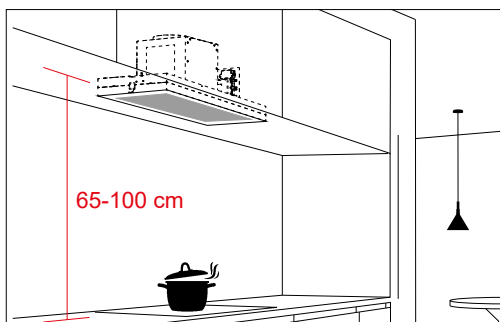
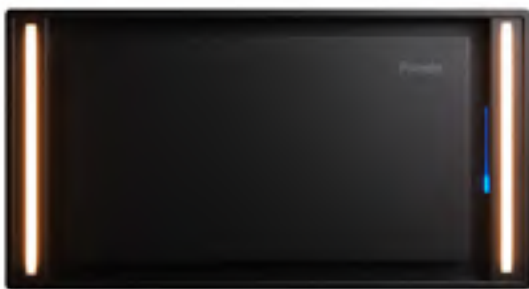

Medidas en / Dimensions in mm



Model. 90 cm.

TIL-2

Inox
Stainless Steel

Motor Interior / Interior Motor. Inox/Stainless Steel

Front. (cm)	Motor	Ø tubo	Clas. Ener.	Ref.
60	V.830	Ø150/120	A	010660
70	V.830	Ø150/120	A	010661
90	V.830	Ø150/120	A	010663
100	V.830	Ø150/120	A	010664

Motor Interior / Interior Motor. Antracita/ Anthracite

Front. (cm)	Motor	Ø tubo	Clas. Ener.	Ref.
80	V.830	Ø150/120	A	010919
120	V.830	Ø150/120	A	010916

Kits de recirculación / Activated carbon filters kit:

Tipo	Ref
FCA	1202679

Notas / Notes

AirClean

Sistema automático de funcionamiento del motor 10 min. cada hora durante 5 horas.
Automatic working motor system for 10 minutes every hour during 5 hours.

Opcionales* / Options*

Opcionales* / Options*

Sistema de filtrado **ECO PLASMA**
ECO PLASMA filter system

Cambio a LED cálido de 3000K. Suministrado con la campana.
LED change to warm light LED 3000K. Available only at the factory.

Mando a distancia electrónico. Suministrado con la campana
Electronic remote control. Available only at the factory

(* Los opcionales se suministrarán junto con la campana. Indicar claramente "OPCIONAL" en el pedido e introducir los datos de forma clara.

(* The optionals will be supplied together with the cooker hood. Indicate clearly 'OPTIONAL' in the order and enter the data clearly.



Incluye Aro reductor de serie
Includes reducer ring as standard
Ø150 a Ø120 mm



Incluye Distanciador de serie
Includes Adapt accessory as standard
Inox Ref. 010656
Negro-black Ref. 010657



Mando a distancia electrónico opcional
Remote electronic Control optional
Ref. 620062200639



Model. 80 cm

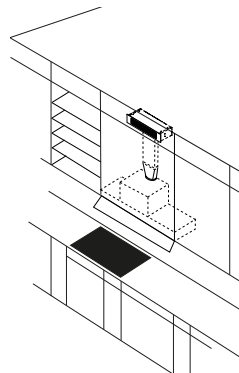

Difusor para comisa filtro cerámico
Cornice diffuser with ceramic filter

Descripción	Ref.
Difusor ALUMINIO / Aluminium diffuser	010653
Difusor BLANCO / White diffuser	010655



Medidas encastre / Built in Sizes 410 x 108 mm

TIL-2

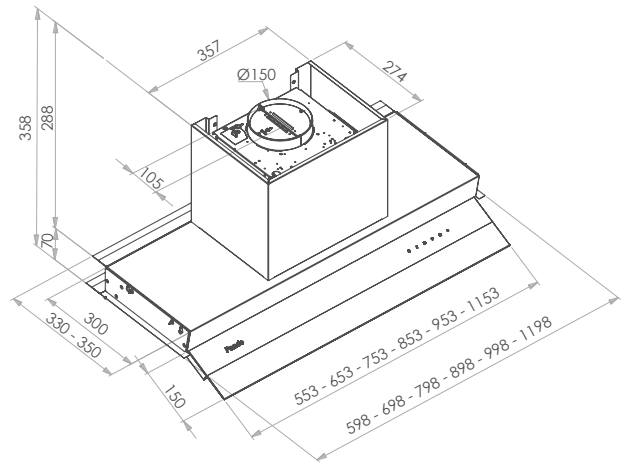

Medidas en / Dimensions in mm

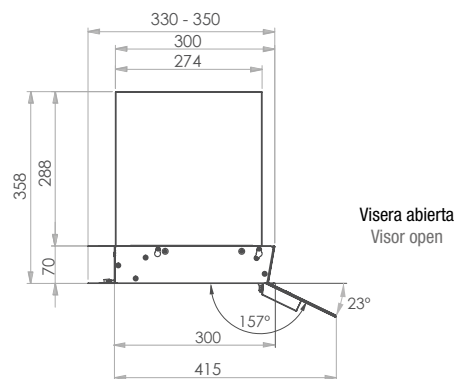

Visera abierta
 Visor open



Model. 90 cm

TIB-2

Inox
Stainless Steel

<p>60 / 70 75 / 80 90 / 100 cm</p>	<p>Elect.</p>	<p>Last TIME</p>	<p>AIR Clean 5h</p>	<p>Opcionales* / Options*</p>
<p>Filters INOX</p>	<p>Filters Auto.</p>	<p>LED 4000K</p>	<p>GAS 65 cm</p>	<p>Kits Recirculation</p>
			<p>IND 55-65 cm</p>	<p>LED 3000K</p>

Motor Interior / Interior Motor

Front. (cm)	Motor	Ø tubo	Clas. Ener.	Ref.
60	V.830	Ø150/120	A	010923 *
70	V.830	Ø150/120	A	010924 *
75	V.830	Ø150/120	A	010525
80	V.830	Ø150/120	A	010926 *
90	V.830	Ø150/120	A	010927 *
100	V.830	Ø150/12	A	010928 *

(*) Modelo con fondo de 300 mm / Model with 300 mm depth

Kits de recirculación / Activated carbon filters kit:

Front. (cm).	Tipo	Ref
60,75,90	FCA	1202678

Opcionales* / Options*

Cambio LED original a LED cálido de 3000K.
LED change to warm light LED 3000K.

(*) Los opcionales se suministrarán junto con la campana. Indicar claramente "OPCIONAL" en el pedido e introducir los datos de forma clara.

(*) The optionals will be supplied together with the cooker hood. Indicate clearly 'OPTIONAL' in the order and enter the data clearly.



Incluye Aro reductor de serie
Includes reducer ring as standard
Ø150 a Ø120 mm

Notas / Notes

AirClean

Sistema automático de funcionamiento del motor 10 min. cada hora durante 5 horas.

Automatic working motor system for 10 minutes every hour during 5 hours.



Model. 90 cm

TIB-2



Detalle botonera / Button panel detail

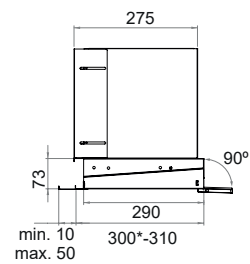
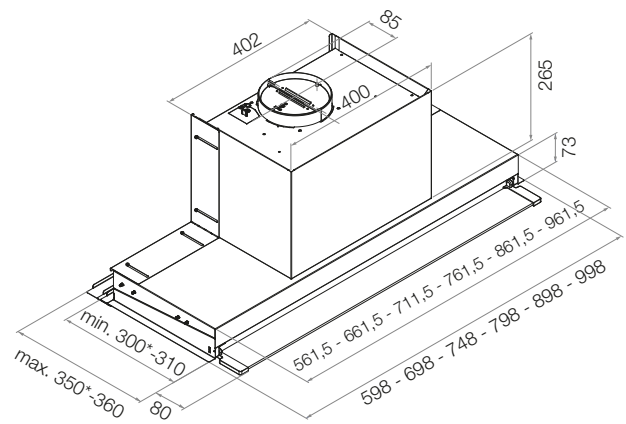







Visera abierta
Visor open

Medidas en / Dimensions in mm

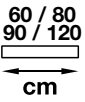

TIM-2

Inox - Negro
Stainless Steel - Black

	 <p>Elect.</p>	 <p>Last TIME</p>	 <p>Filters INOX</p>	 <p>Filters Auto.</p>	<p>Opcionales* / Options*</p>  <p>Kits Recirculation</p>		
 <p>LED 4000K</p>	 <p>SIA Safety</p>	 <p>GAS 65 cm</p>	 <p>IND 55-65 cm</p>	<p>quick fix</p>	 <p>AirLink</p>		
					 <p>Touch</p>	 <p>Pando LED</p>	 <p>Filters ECO PLASMA</p>

S.E.C. System® Motor Interior / Interior Motor

Front. (cm)	Motor	Ø tubo	Clas. Ener.
60	V.850	Ø150/120	A+
80	V.850	Ø150/120	A+
90	V.850	Ø150/120	A+
120	V.850	Ø150/120	A+

Kits de recirculación / Activated carbon filters kit:

Front. (cm).	Tipo	Ref
60	FCRL-AE	1202667
80,90	FCRL-AE	1202668
120	FCRL-AE	1202669

Inox
Stainless Steel

Negro
Black

Opcionales* / Options*

AirLink

Modelo compatible. No se equipa de serie. Imprescindible solicitar en pedido.
Compatible Model. Is not included as standard. Must be ordered.

Sistema de filtrado ECO PLASMA ECO PLASMA filter system

Mando a distancia Touch. Suministrado con la campana.
Remote Control Touch supplied together with the hood.

Substitución de LED original por el Sistema Pando LED
Change of the original LED to the Pando LED system

Juego de tubos
Set of chimneys

(*) Los opcionales se suministrarán junto con la campana. Indicar claramente "OPCIONAL" en el pedido e introducir los datos de forma clara.

(*) The optionals will be supplied together with the cooker hood. Indicate clearly 'OPTIONAL' in the order and enter the data clearly.



Incluye Aro reductor de serie
Includes reducer ring as standard
Ø150 a Ø120 mm



Incluye Distanciador de serie
Includes Adapt accessory as standard
Inox Ref. 010656
Negro-black Ref. 010657



Mando a distancia opcional
Remote Touch Control optional
Ref. 620062200478



Model. 80 cm

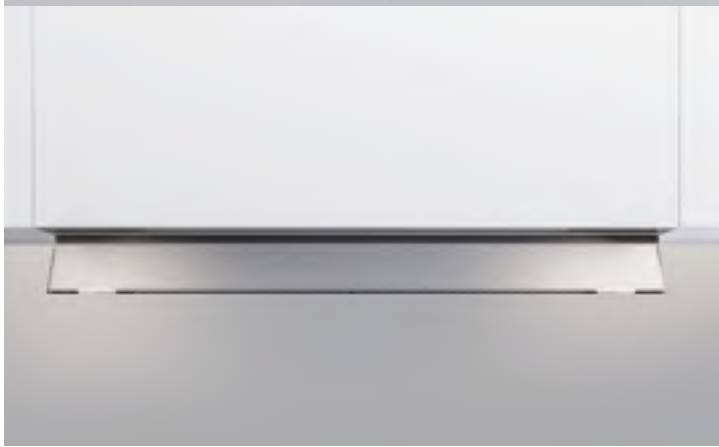

TIM-2



Sistema de fácil instalación.
Easy installation system.

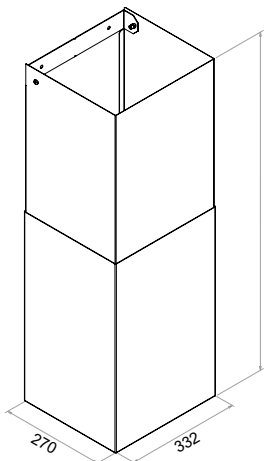

Opcional
Optional

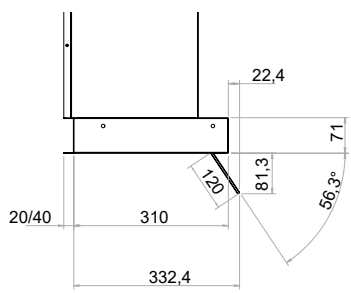

Visera abierta
Visor open

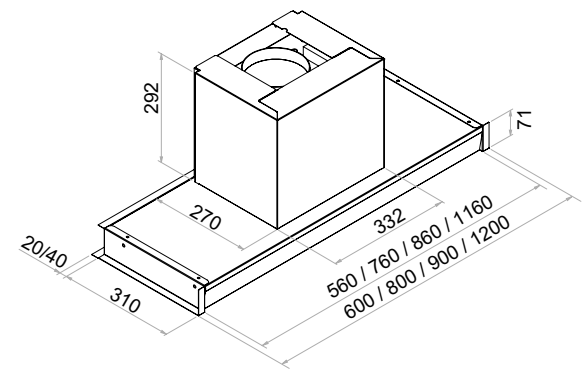

Medidas en / Dimensions in mm



Model. 90 cm. Antracita

TIX

Inox - Antracita
Stainless Steel - Anthracite

							Opcionales* / Options*

S.E.C. System®

Motor Interior / Interior Motor

Front. (cm)	Motor	Ø tubo	Clas. Ener.
60	V.850	Ø150/120	A
	V.1050 eco SEC® PLUS	Ø150	A+
90	V.850	Ø150/120	A
	V.1050 eco SEC® PLUS	Ø150	A+
	V.1250 eco	Ø150	A+
120	V.850	Ø150/120	A
	V.1050 eco SEC® PLUS	Ø150	A
	V.1250 eco	Ø150	A+

Antracita
Anthracite

Inox
Stainless Steel

Opcionales* / Options*

AirLink

Modelo compatible. No se equipa de serie. Imprescindible solicitar en pedido.
Compatible Model. Is not included as standard. Must be ordered.

Sistema de filtrado ECO PLASMA

ECO PLASMA filter system

Mando a distancia Touch. Suministrado con la campana.
Remote Control Touch supplied together with the hood.

Juego de tubos hasta altura total de 940 mm
Set of chimneys to a total height of 940 mm

(*) Los opcionales se suministrarán junto con la campana. Indicar claramente "OPCIONAL" en el pedido e introducir los datos de forma clara.

(*) The optionals will be supplied together with the cooker hood. Indicate clearly 'OPTIONAL' in the order and enter the data clearly.

Kits de recirculación / Activated carbon filters kit:

Front. (cm)	Tipo	Ref
60	FCRL-AE	1200227
90	FCRL-AE	1200228
120	FCRL-AE	1200229

AirClean

Sistema automático de funcionamiento del motor 10 min. cada hora durante 5 horas.
Automatic working motor system for 10 minutes every hour during 5 hours.



Motor V.850

Incluye Aro reductor de serie
Includes reducer ring as standard
Ø150 a Ø120 mm



Incluye Distanciador de serie

Includes Adapt accessory as standard
Inox Ref. 010656
Negro-black Ref. 010657



Mando a distancia opcional

Remote Touch Control optional
Ref. 620062200478



Model. 90 cm



TIX

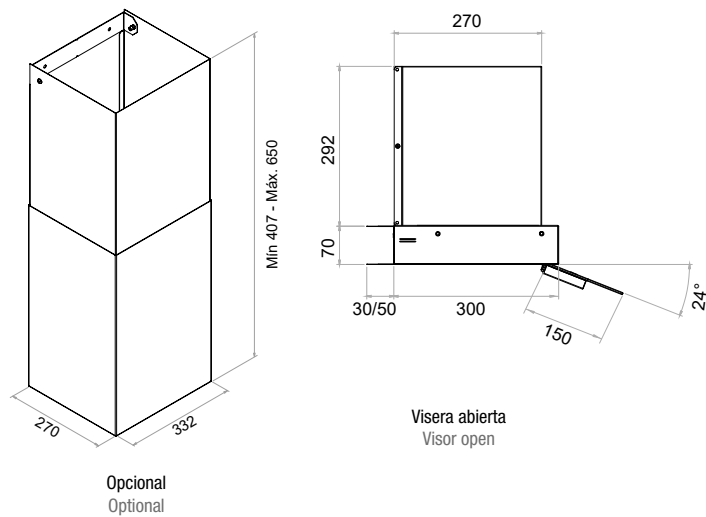

Sistema de fácil instalación.
Easy installation system.

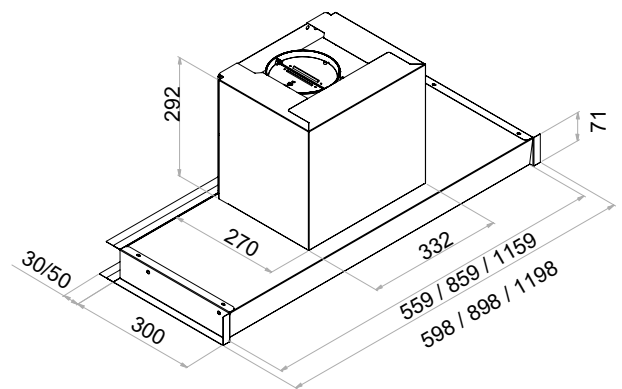

Medidas en / Dimensions in mm



GIM2

Inox - Frontal panelable
Stainless Steel - panelable front

<p>60 / 90 / 120 cm</p>	<p>Elect.</p>	<p>Last TIME</p>	<p>Filters INOX</p>	<p>Kits Recirculation</p>
<p>Filters Auto.</p>	<p>LED 4000K</p>	<p>SIA Safety</p>	<p>GAS 65 cm</p>	<p>Touch</p>
			<p>IND 55-65cm</p>	<p>LED 3000K</p>
				<p>AirLink</p>
				<p>Filters ECO PLASMA</p>

S.E.C. System® Motor Interior / Interior Motor

Front. (cm)	Motor	Ø tubo	Clas. Ener.	Ref.
60	V.850	Ø150	A	008616
90	V.850	Ø150	A	007966
120	V.850	Ø150	A	007969

Kits de recirculación / Activated carbon filters kit:

Model	Tipo	Ref
GIM2	FCA	1202582

Mando a distancia
Remote Touch Control
Ref. 620062200478



Opcionales* / Options*

AirLink

Modelo compatible. No se equipa de serie. Imprescindible solicitar en pedido.
Compatible Model. Is not included as standard. Must be ordered.

Sistema de filtrado ECO PLASMA

ECO PLASMA filter system

Mando a distancia Touch. Suministrado con la campana.

Remote Control Touch supplied together with the hood.

Cambio a LED cálido de 3000K. Suministrado con la campana.

LED change to warm light LED 3000K. Available only at the factory.

Opción de salida trasera. Indicar en pedido.

Option of rear exit, has to be mentioned in the order.

(* Los opcionales se suministrarán junto con la campana. Indicar claramente "OPCIONAL" en el pedido e introducir los datos de forma clara.

(* The optionals will be supplied together with the cooker hood. Indicate clearly 'OPTIONAL' in the order and enter the data clearly.

Notas / Notes

Incluye de serie perfil protector para la puerta del mueble.

Includes profile protector as standard for the door.

Incorpora bandeja de fácil limpieza que recoge las grasas de la cocción de los filtros.

Includes easy-cleaning tray for collection of oils.

Consultar ficha técnica de herrajes para peso máximo y medidas recomendables de la puerta panelable.

See hardware technology sheet for maximum weight and sizes recommended for the panel.



Model. GIM2 60 cm

GIM2



Perfil inox protector del mueble
Stainless steel profile protection for the furniture

GIM2 **Altura / Height: 390 mm**
Fondo / Depth: 325 mm

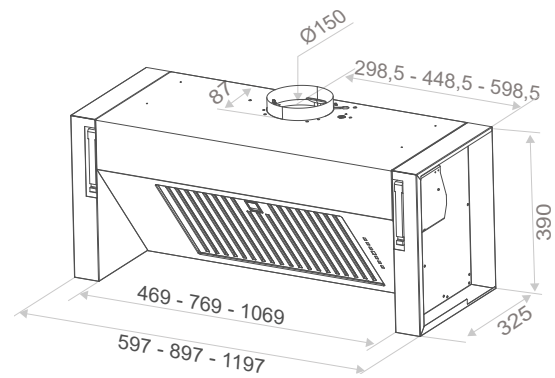

Medidas en / Dimensions in mm



Model. 90 cm

BGF S.E.C. System

Inox
Stainless Steel

Compatible EVOLIKE

50 / 75
99 / 124
cm

eco



Elect.



Filters
INOX



AIR
Clean
5h



Filters
Auto.



LED
4000K



SIA
Safety



GAS
65 cm



IND
55-65 cm

Opcionales* / Options*



Kits
Recirculation

AirLink



LED
3000K



Touch



Filters
ECO
PLASMA

S.E.C. System® Motor Interior / Interior Motor

Front. (cm)	Motor	Ø tubo	Clas. Ener.	Ref.
50	V.750	Ø125	B	008504
	V.850	Ø150	A	006810
	V.1050 eco	Ø150	A+	009671
75	V.750	Ø125	B	008508
	V.850	Ø150	A	006811
	V.1050 eco	Ø150	A+	009624
99	V.1250 eco	Ø150	A++	008509
	V.750	Ø125	B	008512
	V.850	Ø150	A	006812
124	V.1050 eco	Ø150	A+	009628
	V.1250 eco	Ø150	A+	008513
	V.850	Ø150	A	006813
	V.1250 eco	Ø150	A++	008516

Motor Intermedio exterior / Duct-in-line motor

75	V.1550 eco	Ø150	A+	009625
	V.1550 eco	Ø150	A+	009629
99	V.2450 eco	Ø200	A+	009631
	V.1550 eco	Ø150	A+	009635
124	V.2450 eco	Ø200	A+	009637

Motor de tejado / Remote motor -Roof Outdoor

99	V.2350 eco	Ø200	A+	009632
124	V.2350 eco	Ø200	A+	009638

Mando a distancia
Remote Touch Control
Ref. 620062200478



Profundidad 460 mm / Depth 460 mm

Medidas Encastre Built in Sizes

50	502 x 437
75	750 x 437
99	997 x 437
124	1245 x 437

Medidas en / Dimensions in mm

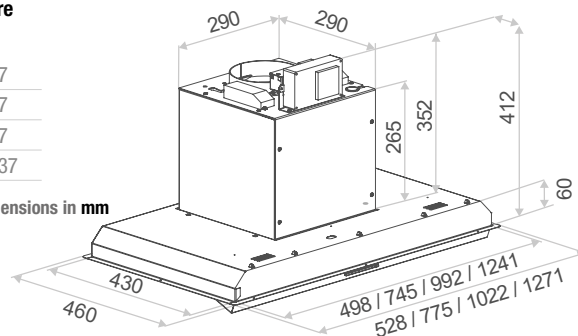

Opcionales* / Options*

AirLink

Modelo compatible. No se equipa de serie. Imprescindible solicitar en pedido.
Compatible Model. Is not included as standard. Must be ordered.

Sistema de filtrado ECO PLASMA
ECO PLASMA filter system

Mando a distancia Touch.
Remote Control Touch.

Cambio LED original a LED cálido de 3000K.
LED change to warm light LED 3000K.

(*) Los opcionales se suministrarán junto con la campana. Indicar claramente "OPCIONAL" en el pedido e introducir los datos de forma clara.

(*) The optionals will be supplied together with the cooker hood. Indicate clearly 'OPTIONAL' in the order and enter the data clearly.

Kits de recirculación / Activated carbon filters kit:

Front. (cm).	Tipo	Ref
50	FCRL-AE	1200204
75	FCRL-AE	1202519
99	FCRL-AE	1200187
124	FCRL-AE	1202554



PGF

Inox
Stainless Steel

<p>60 / 70 cm</p>	<p>Slider</p>	<p>Filters ALU</p>	<p>Opcionales* / Options*</p> <p>Kits Recirculation</p>
<p>LED 4000K</p>	<p>GAS 65 cm</p>	<p>IND 55-65 cm</p>	

Motor Interior / Interior Motor

Front. (cm)	Motor	Ø tubo	Clas. Ener.	Ref.
60	V.730	Ø120	A	009954
70	V.730	Ø120	A	009955

Kits de recirculación / Activated carbon filters kit:

Front. (cm).	Tipo	Ref
60, 70	FCA	1202605

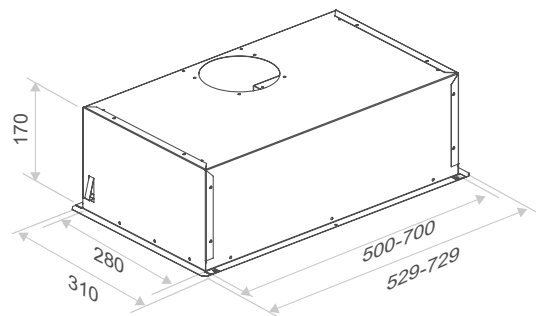

Medidas en / Dimensions in mm

Opcionales* / Options*

Cambio a LED de luz cálida de 3000K.
LED change to warm light LED 3000K.

(*) Los opcionales se suministrarán junto con la campana. Indicar claramente "OPCIONAL" en el pedido e introducir los datos de forma clara.

(*) The optional will be supplied together with the cooker hood. Indicate clearly 'OPTIONAL' in the order and enter the data clearly.

Medidas encastre Built in Sizes

60	505 x 285
70	705 x 285



Model. 60 cm

IES S.E.C. System

Inox
Stainless Steel



Last TIME



SIA
Safety



Opcionales* / Options*



S.E.C. System®

Motor Interior / Interior Motor

Front. (cm)	Motor	Ø tubo	Clas. Ener.	Ref.
60	V.830	Ø150/120	A	010697
90	V.830	Ø150/120	A	010700

Opcionales* / Options*

Cambio a LED cálido de 3000K.
LED change to warm light LED 3000K.

(*) Los opcionales se suministrarán junto con la campana. Indicar claramente "OPCIONAL" en el pedido e introducir los datos de forma clara.

(*) The optionals will be supplied together with the cooker hood. Indicate clearly 'OPTIONAL' in the order and enter the data clearly.

Kits de recirculación / Activated carbon filters kit:

Front. (cm).	Tipo	Ref
90,90	FCA	1200215

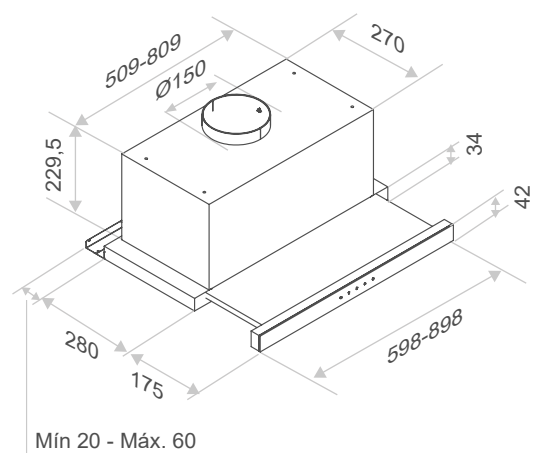

Medidas en / Dimensions in mm



Incluye Aro reductor de serie
Includes reducer ring as standard
Ø150 a Ø120 mm



IES Touch S.E.C. System

Inox - Frontal cristal negro o blanco
Stainless Steel - Front black o white glass

					Opcionales* / Options*	

S.E.C. System® Motor Interior / Interior Motor

Front. (cm)	Motor	Ø tubo	Clas. Ener.
60	V.830	Ø150/120	
90	V.830	Ø150/120	

Cristal negro
Black Glass

Cristal Blanco
White Glass

Opcionales* / Options*

Cambio LED original a LED cálido de 3000K.
LED change to warm light LED 3000K.

(*) Los opcionales se suministrarán junto con la campana. Indicar claramente "OPCIONAL" en el pedido e introducir los datos de forma clara.
(* The optionals will be supplied together with the cooker hood. Indicate clearly 'OPTIONAL' in the order and enter the data clearly.

Kits de recirculación / Activated carbon filters kit:

Front. (cm).	Tipo	Ref
90,90	FCA	1200215

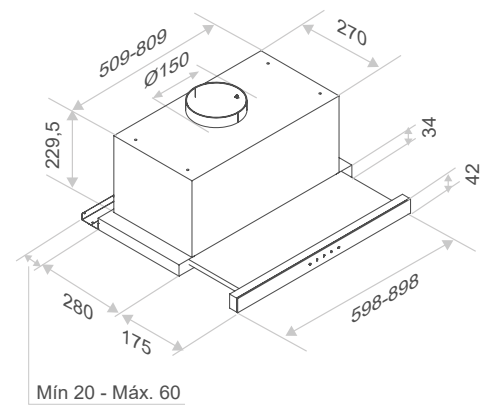

Medidas en / Dimensions in mm



Incluye Aro reductor de serie
Includes reducer ring as standard
Ø150 a Ø120 mm



Model. 90 cm

ES

Inox
Stainless Steel

<p>60 / 70 90 cm</p>	<p>Elect.</p>	<p>Filters INOX</p>	<p>Opcionales* / Options*</p> <div style="display: flex; justify-content: space-around; align-items: center;"> <div style="text-align: center;"> <p>Kits Recirculation</p> </div> <div style="text-align: center;"> <p>LED 3000K</p> </div> </div>
<p>LED 4000K</p>	<p>GAS 65 cm</p>	<p>IND 55-65cm</p>	

S.E.C. System®

Motor Interior / Interior Motor

Front. (cm)	Motor	Ø tubo	Clas. Ener.	Ref.
60	V.730	Ø120	A	009956
70	V.730	Ø120	A	009957
90	V.730	Ø120	A	009958

Opcionales* / Options*

Cambio LED original a LED cálido de 3000K.
LED change to warm light LED 3000K.

(*) Los opcionales se suministrarán junto con la campana. Indicar claramente "OPCIONAL" en el pedido e introducir los datos de forma clara.

(*) The optionals will be supplied together with the cooker hood. Indicate clearly 'OPTIONAL' in the order and enter the data clearly.

Kits de recirculación / Activated carbon filters kit:

Front. (cm).	Tipo	Ref
60,70,90	FCA	1202605

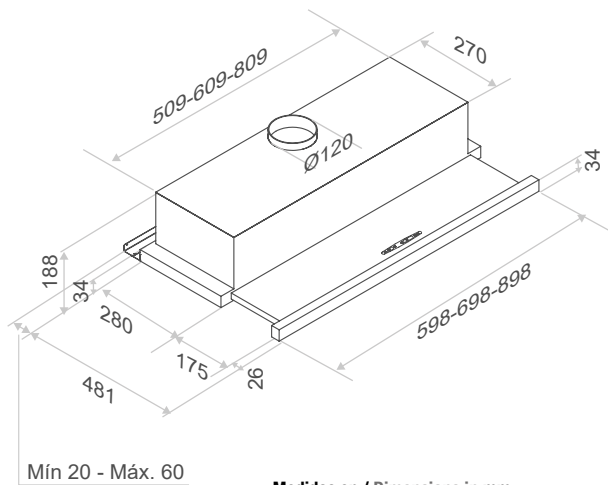

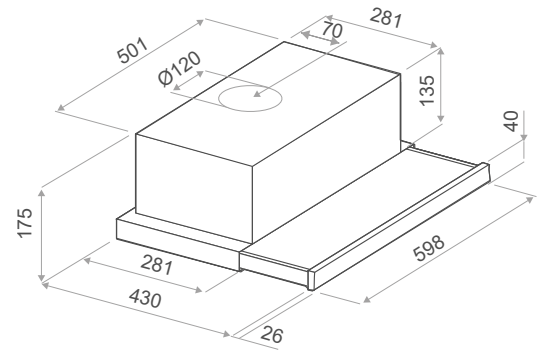

Medidas en / Dimensions in mm

GR20

 60 cm	 Mecanic	 Filters ALU	Opcionales* / Options* Kits Recirculation Solo para modelo Only for model Ref. 010046
 LED 3000K	 GAS 65 cm	 IND 55-65cm	

Kits de recirculación / Activated carbon filters kit:

Front. (cm).	Tipo	Ref
60	FCA	1202644

Motor Interior / Interior Motor

Front. (cm)	Motor	Ø tubo	Clas. Ener.	Ref.
60	V.700	Ø120		010046
	V.700 ECS	Ø120		010047

Opcionales* / Options*

Kits de recirculación. Solo para modelo **ref. 010046**
Recirculation Kit. Only for model **ref. 010046**

(*) Los opcionales se suministrarán junto con la campana.
Indicar claramente "OPCIONAL" en el pedido e introducir los datos de forma clara.
(* The optionals will be supplied together with the cooker hood.
Indicate clearly 'OPTIONAL' in the order and enter the data clearly.

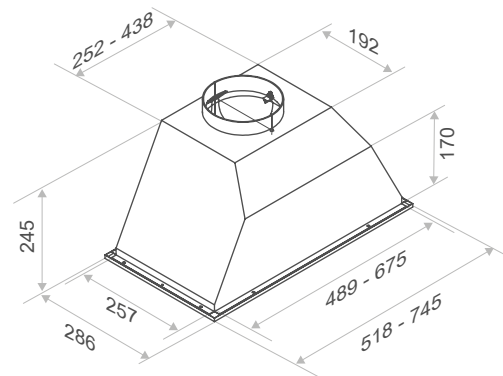

Medidas en / Dimensions in mm

GR05

 60 / 90 cm	 Slider	 Filters ALU	Opcionales* / Options* Kits Recirculation
 LED 4000K	 GAS 65 cm	 IND 55-65cm	

Kits de recirculación / Activated carbon filters kit:

Motor	Tipo	Ref
V.700	FCA	1200097
V.730	FCA	1202605

Medidas encastre Built in Sizes

60	493 x 260
90	679 x 260

Motor Interior / Interior Motor

Front. (cm)	Motor	Ø tubo	Clas. Ener.	Ref.
60	V.700	Ø150		009672
	V.730	Ø120		010024
90	V.700	Ø150		009673
	V.730	Ø120		010025

CAMPANAS DE PARED

COOKER HOODS WALL

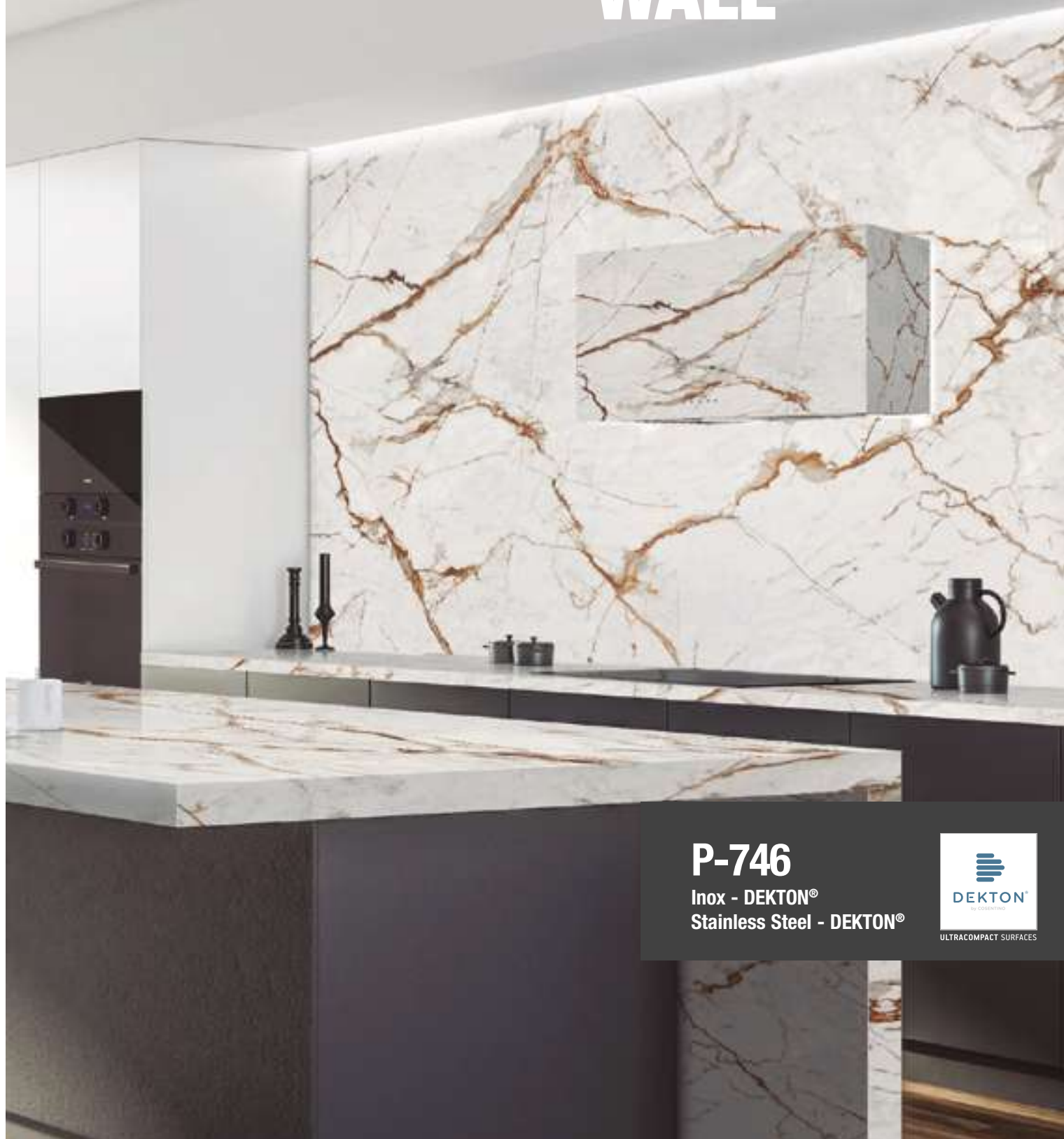

P-746

Inox - DEKTON®

Stainless Steel - DEKTON®



ULTRACOMPACT SURFACES

P-221
p.114

P-227
p.115

P-300
P-330
p.116

P-401
p.118

P-417
p.120

P-725
p.122

P-732
p.124

P-746
p.112

P-823N
p.126



P-825
p.128

P-826
p.127

P-827
p.130

P-842/6
P-842/11
p.132

P-861
p.134

P-898
p.138

P-1001
p.140

P-2000
P-2000
Vintage
p.142

P-2010
p.144

P-746

Inox - DEKTON®

Stainless Steel - DEKTON®



SEC
System
PLUS

eco



Last
TIME

AIR
Clean
5h



SIA
Safety



Opcionales* / Options*



AirLink



Embellecedor a techo
Ceiling trim
Ref. 7118

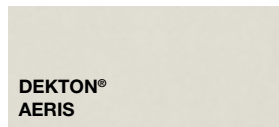

Mando a distancia
Remote Touch Control
Ref. 620062200478

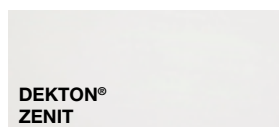
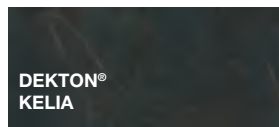

Opcionales* / Options*

AirLink

Modelo compatible. No se equipa de serie. Imprescindible solicitar en pedido.

Compatible Model. Is not included as standard. Must be ordered.

Embellecedor a techo / Ceiling trim. Ref. 7118

Mando a distancia Touch. Suministrado con la campana.
Remote Control Touch supplied together with the hood.

Juego de tubos. Altura total hasta 1500 mm*
Set of chimneys to a total height of 1500 mm*

Juego de tubos. Altura total entre 1501 y 2000 mm*
Set of chimneys to a total height of between 1501 and 2000 mm*

(*) Los opcionales se suministrarán junto con la campana. Indicar claramente "OPCIONAL" en el pedido e indicar la medida exacta de los tubos.

(*) The optionals will be supplied together with the cooker hood. Indicate clearly 'OPTIONAL' in the order and indicate the exact size of the chimneys.

Este modelo incorpora tubos de salida de humos. / This model incorporate chimney

S.E.C. System® Motor Interior / Interior Motor

	Front. (cm)	Motor	Ø tubo	Clas. Ener.	Ref.
DEKTON® LAURENT	90	V.850	Ø150	A	010245
		V.1050 eco SEC® PLUS	Ø150	A+	010246
DEKTON® LAURENT	120	V.850	Ø150	A	010443
		V.1050 eco SEC® PLUS	Ø150	A+	010444
DEKTON® AERIS	90	V.850	Ø150	A	010247
		V.1050 eco SEC® PLUS	Ø150	A+	010248
DEKTON® AERIS	120	V.850	Ø150	A	010445
		V.1050 eco SEC® PLUS	Ø150	A+	010446
DEKTON® KELYA	90	V.850	Ø150	A	010249
		V.1050 eco SEC® PLUS	Ø150	A+	010250
DEKTON® KELYA	120	V.850	Ø150	A	010447
		V.1050 eco SEC® PLUS	Ø150	A+	010448
DEKTON® TRILIUM	90	V.850	Ø150	A	010251
		V.1050 eco SEC® PLUS	Ø150	A+	010252
DEKTON® TRILIUM	120	V.850	Ø150	A	010449
		V.1050 eco SEC® PLUS	Ø150	A+	010450
DEKTON® ZENITH	90	V.850	Ø150	A	010253
		V.1050 eco SEC® PLUS	Ø150	A+	010254
DEKTON® ZENITH	120	V.850	Ø150	A	010451
		V.1050 eco SEC® PLUS	Ø150	A+	010452
DEKTON® REVERIE	90	V.850	Ø150	A	010873
		V.1050 eco SEC® PLUS	Ø150	A+	010874
DEKTON® REVERIE	120	V.850	Ø150	A	010875
		V.1050 eco SEC® PLUS	Ø150	A+	010876

RECIRCULACIÓN / RECIRCULATION FCLR-AE

Este modelo NO incorpora tubos de salida de humos. / This model does NOT incorporate chimney

S.E.C. System® Motor Interior / Interior Motor

	Front. (cm)	Motor	Ø tubo	Ref.
DEKTON® LAURENT	90	V.850	Ø150	010301
		V.1050 eco SEC® PLUS	Ø150	010302
DEKTON® LAURENT	120	V.850	Ø150	010453
		V.1050 eco SEC® PLUS	Ø150	010454
DEKTON® AERIS	90	V.850	Ø150	010303
		V.1050 eco SEC® PLUS	Ø150	010304
DEKTON® AERIS	120	V.850	Ø150	010455
		V.1050 eco SEC® PLUS	Ø150	010456
DEKTON® KELYA	90	V.850	Ø150	010305
		V.1050 eco SEC® PLUS	Ø150	010306
DEKTON® KELYA	120	V.850	Ø150	010457
		V.1050 eco SEC® PLUS	Ø150	010458
DEKTON® TRILIUM	90	V.850	Ø150	010307
		V.1050 eco SEC® PLUS	Ø150	010308
DEKTON® TRILIUM	120	V.850	Ø150	010459
		V.1050 eco SEC® PLUS	Ø150	010460
DEKTON® ZENITH	90	V.850	Ø150	010309
		V.1050 eco SEC® PLUS	Ø150	010310
DEKTON® ZENITH	120	V.850	Ø150	010461
		V.1050 eco SEC® PLUS	Ø150	010462
DEKTON® REVERIE	90	V.850	Ø150	010877
		V.1050 eco SEC® PLUS	Ø150	010878
DEKTON® REVERIE	120	V.850	Ø150	010879
		V.1050 eco SEC® PLUS	Ø150	010880



Model. 90 cm



Kits de recirculación / Activated carbon filters kit:

Front. (cm).	Tipo	Ref
90	FCRL-AE	1200231
120	FCRL-AE	1200250

Notas / Notes

El material DEKTON® tiene un grosor de 4 mm
 DEKTON® material is 4 mm thick

AirClean

Sistema automático de funcionamiento del motor 10 min. cada hora durante 5 horas.
 Automatic working motor system for 10 minutes every hour during 5 hours.

P-746

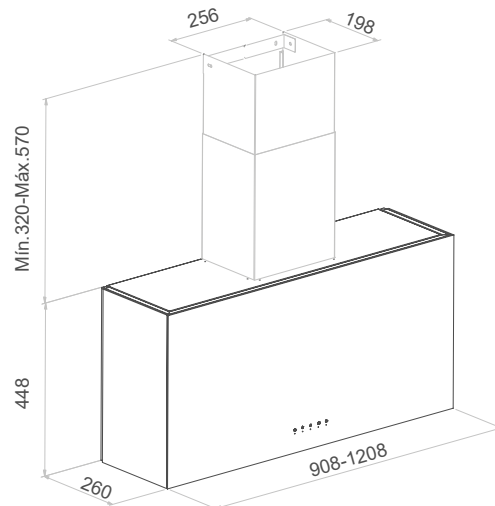

Medidas en / Dimensions in mm
Tubos especiales a medida / Special custom-made chimneys
Tubo salida de humos de serie en la versión aspirante. /
Chimney as standard on suction version

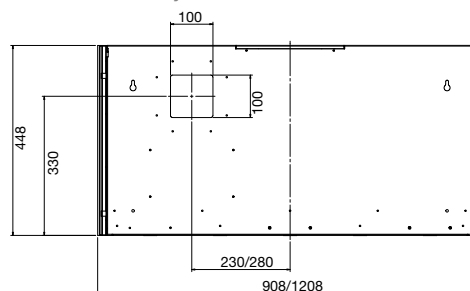



Model. 90 cm

P-221 Inox Stainless Steel

60 / 70 / 90
cm



Mecanic



Filters
ALU



LED
4000K



GAS
65 cm

Opcionales* / Options*



Kits
Recirculation



Tubos
Chimney



Embell. techo
Ceiling trim.

S.E.C. System®

Motor Interior / Interior Motor

Front. (cm)	Motor	Ø tubo	Clas. Ener.	Ref.
60	V.730 ECS	Ø120	A	010081
70	V.730 ECS	Ø120	A	010082
90	V.730 ECS	Ø120	A	010083

Opcionales* / Options*

Embellecedor a techo / Ceiling trim. **Ref. 7118**

Juego de tubos. Altura total hasta **1500 mm***

Set of chimneys to a total height of **1500 mm***

Juego de tubos. Altura total entre **1501 y 2000 mm***

Set of chimneys to a total height of between **1501 and 2000 mm***

(*) Los tubos se suministrarán junto con la campana. Indicar claramente "OPCIONAL" en el pedido e indicar la medida exacta de los tubos.

(*) The optionals will be supplied together with the cooker hood. Indicate clearly 'OPTIONAL' in the order and indicate the exact size of the chimneys.

Kits de recirculación / Activated carbon filters kit:

Front. (cm).	Acabado Finished	Tipo	Ref
60, 70, 90	INOX	FCA	1202647

Notas* / Notes*

Altura recomendada de instalación desde la zona de cocción a la base de la campana 50 cm. Para altura mínima 65 cm.

The recommended distance between the base of the hood and cooking area is 50 cm. The minimum distance between the base of the hood and a gas hob is 65 cm.

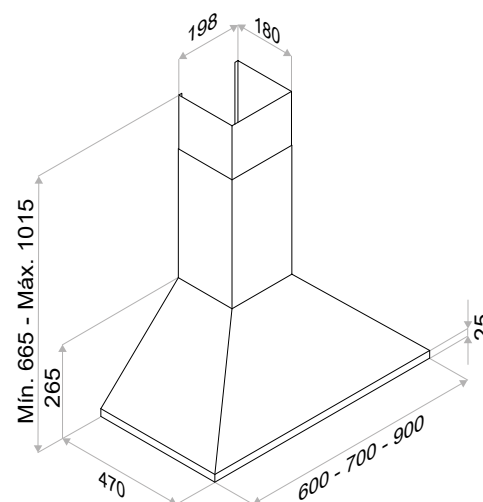

Medidas en / Dimensions in mm
Tubos especiales a medida / Special custom-made chimneys



Embellecedor a techo
Ceiling trim
Ref. 7118



Model. 90 cm

P-227 Inox Stainless Steel

60 / 70 / 90 cm	Elect.	SIA Safety	Last TIME	AIR Clean 5h
Filters INOX	Filters Auto.	LED 4000K	GAS 65 cm	

Opcionales* / Options*

Kits Recirculation	AirLink	
Touch	Tubos Chimney	Embell. techo Ceiling trim.

S.E.C. System®

Motor Interior / Interior Motor

Front. (cm)	Motor	Ø tubo	Clas. Ener.	Ref.
60	V.830	Ø150/120	A	010704
70	V.830	Ø150/120	A	010705
90	V.830	Ø150/120	A	010706

Opcionales* / Options*

AirLink

Modelo compatible. No se equipa de serie. Imprescindible solicitar en pedido.
Compatible Model. Is not included as standard. Must be ordered.

Embellecedor a techo / Ceiling trim. **Ref. 7118**

Mando a distancia Touch. Suministrado con la campana.
Remote Control Touch supplied together with the hood.

Juego de tubos. Altura total hasta **1500 mm***
Set of chimneys to a total height of **1500 mm***

Juego de tubos. Altura total entre **1501 y 2000 mm***
Set of chimneys to a total height of between **1501 and 2000 mm***

Kits de recirculación / Activated carbon filters kit:

Front. (cm).	Acabado Finished	Tipo	Ref
60	INOX	FCRL-AE	1202614
70	INOX	FCRL-AE	1202615
90	INOX	FCRL-AE	1202616

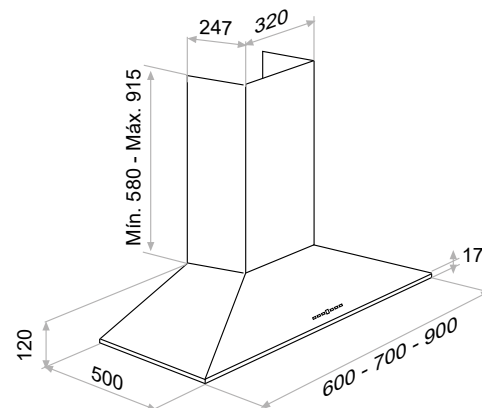

Medidas en / Dimensions in mm
Tubos especiales a medida / Special custom-made chimneys



Embellecedor a techo
Ceiling trim
Ref. 7118

Mando a distancia
Remote Touch Control
Ref. 620062200478

Incluye Aro reductor de serie
Includes reducer ring as standard
Ø150 a Ø120 mm

(*) Los tubos se suministrarán junto con la campana. Indicar claramente "OPCIONAL" en el pedido e indicar la medida exacta de los tubos.

(*) The optionals will be supplied together with the cooker hood. Indicate clearly 'OPTIONAL' in the order and indicate the exact size of the chimneys.



P-300

Inox
Stainless Steel

P-330

Cristal - Touch Control
Glass - Touch control

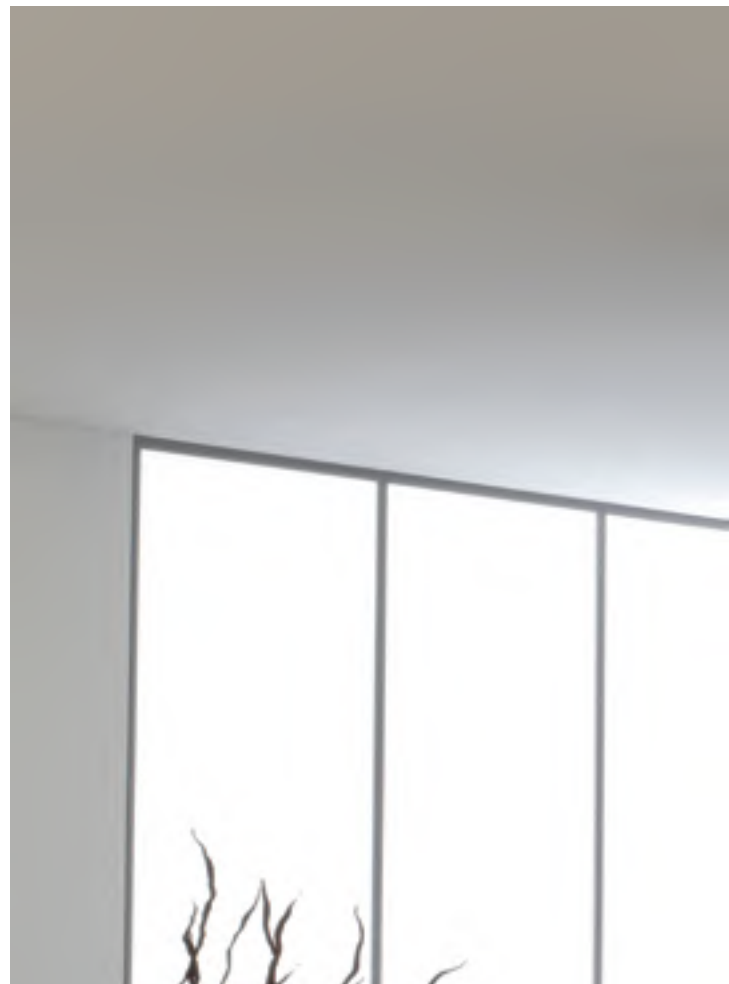

Opcionales* / Options*



AirLink



S.E.C. System® Motor Interior / Interior Motor

Motor	Ø tubo
V.750	Ø125
V.850	Ø150
V.1050 eco SEC® PLUS	Ø150
V.1250 eco	Ø150
V.2200 eco	Ø200

Motor Intermedio exterior / Duct-in-line motor

V.1550 eco	Ø150
V.2450 eco	Ø200
V.3000 eco	Ø200

Motor Exterio a muro / Remote motor - Wall Outdoor

V.1300	Ø150
--------	------

Motor de tejado / Remote motor -Roof Outdoor

V.2350 eco	Ø200
V.3300 eco	Ø200

Opcionales* / Options*

AirLink

Modelo compatible. No se equipa de serie. Imprescindible solicitar en pedido.
Compatible Model. Is not included as standard. Must be ordered.

Mando a distancia Touch. Suministrado con la campana.
Remote Control Touch supplied together with the hood.

Modelo personalizable en cualquier color de la carta RAL. Bajo presupuesto.
Customizable model in any color from the RAL chart. On request.



Cristal
Model. 90 cm

P-300 / P-330

Notas / Notes

P-330

Botonera TOUCH únicamente en acabados blanco o negro brillo.
Resto de colores, incorporan botonera electrónica + Last Time en zona inferior.
TOUCH control only in glossy black or white finish.
The rest of the colours incorporate electronic control + Last Time in lower section.

P-330 - AirClean

Sistema automático de funcionamiento del motor 10 min. cada hora durante 5 horas.
Automatic working motor system for 10 minutes every hour during 5 hours.



Mando a distancia
Remote Touch Control
Ref. 620062200478

**Fabricadas a medida.
Custom Made.**

Altura mínima para campanas especiales 500 mm.
Para modelo de recirculación, altura mínima de 700 mm.
Minimum height for special hoods 500 mm.

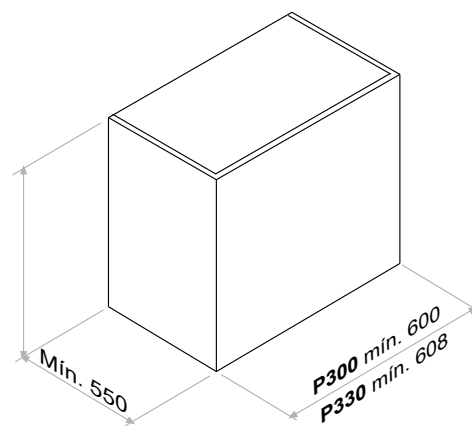

Medidas en / Dimensions in mm



P-401

Inox
Stainless Steel

							Opcionales* / Options*					

S.E.C. System® Motor Interior / Interior Motor

Front. (cm)	Motor	Ø tubo	Clas. Ener.	Ref.
70	V.750	Ø125	B	009750
	V.850	Ø150	A+	009751
	V.1050 eco SEC® PLUS	Ø150	A+	009752
	V.1250 eco	Ø150	A++	009753
80	V.750	Ø125	B	008176
	V.850	Ø150	A+	006865
	V.1050 eco SEC® PLUS	Ø150	A+	009269
	V.1250 eco	Ø150	A++	008177
90	V.750	Ø125	B	008180
	V.850	Ø150	A+	006866
	V.1050 eco SEC® PLUS	Ø150	A+	009275
	V.1250 eco	Ø150	A++	008181
120	V.850	Ø150	A+	006867
	V.1050 eco SEC® PLUS	Ø150	A+	009281
	V.1250 eco	Ø150	A+	008184

(*) Los tubos se suministrarán junto con la campana. Indicar claramente "OPCIONAL" en el pedido e indicar la medida exacta de los tubos.

(*) The optionals will be supplied together with the cooker hood. Indicate clearly 'OPTIONAL' in the order and indicate the exact size of the chimneys.

Kits de recirculación / Activated carbon filters kit:

Front. (cm).	Acabado Finished	Tipo	Ref
70	INOX	FCRL-AE	1202569
80	INOX	FCRL-AE	1200062
90	INOX	FCRL-AE	1200035
120	INOX	FCRL-AE	1200102

Opcionales* / Options*

AirLink

Modelo compatible. No se equipa de serie. Imprescindible solicitar en pedido. Compatible Model. Is not included as standard. Must be ordered.

Sistema de filtrado **ECO PLASMA**
ECO PLASMA filter system

Embellecedor a techo / Ceiling trim. **Ref. 7118**

Mando a distancia Touch. Suministrado con la campana.
Remote Control Touch supplied together with the hood.

Juego de tubos. Altura total hasta **1500 mm***
Set of chimneys to a total height of **1500 mm***

Juego de tubos. Altura total entre **1501 y 2000 mm***
Set of chimneys to a total height of between **1501 and 2000 mm***

Modelo personalizable en cualquier color de la carta RAL. Bajo presupuesto.
Customizable model in any color from the RAL chart. On request.



Model. 90 cm

P-401

Notas / Notes

Modelos Carbon activado / Activated carbon models

Las medidas de los tubos serán: Mín. 645 - Máx. 1045

The flues will be as follows: Min. 645 - Máx. 1045

AirClean

Sistema automático de funcionamiento del motor 10 min. cada hora durante 5 horas.
Automatic working motor system for 10 minutes every hour during 5 hours.



Embellecedor a techo
Ceiling trim
Ref. 7118



Mando a distancia
Remote Touch Control
Ref. 620062200478

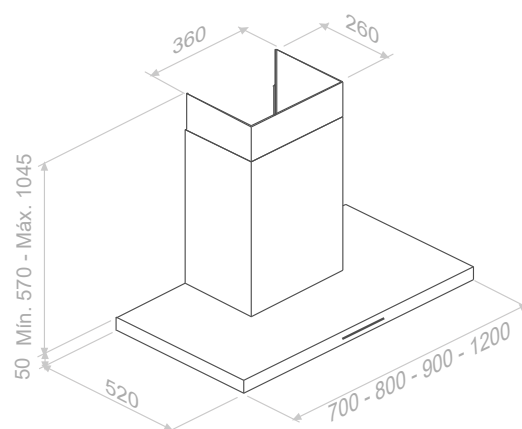

Medidas en / Dimensions in mm
Tubos especiales a medida / Special custom-made chimneys



P-417

Inox - Retroiluminado con led
Stainless Steel - LED backlit



	SEC System PLUS	eco		Last TIME	AIR Clean 5h
		LED 4000K	LED Ambient	SIA Safety	GAS 65 cm

Opcionales* / Options*

	AirLink			

S.E.C. System® Motor Interior / Interior Motor

Front. (cm)	Motor	Ø tubo	Clas. Ener.	Ref.
	V.850	Ø150/120	A	009204
90	V.1050 eco SEC® PLUS	Ø150	A+	009290
	V.1250 eco	Ø150	A++	009291

Kits de recirculación / Activated carbon filters kit:

Front. (cm)	Acabado Finished	Tipo	Ref
90	INOX	FCRL-AE	1202563

Opcionales* / Options*

AirLink

Modelo compatible. No se equipa de serie. Imprescindible solicitar en pedido.
Compatible Model. Is not included as standard. Must be ordered.

Sistema de filtrado **ECO PLASMA**
ECO PLASMA filter system

Embellecedor a techo / Ceiling trim. **Ref. 7118**

Opción de cambio de LED original a LED de luz cálida de 3000K.
LED change to warm light LED 3000K. Available only at the factory

Mando a distancia Touch. Suministrado con la campana.
Remote Control Touch supplied together with the hood.

Juego de tubos. Altura total hasta **1500 mm***
Set of chimneys to a total height of **1500 mm***

Juego de tubos. Altura total entre **1501 y 2000 mm***
Set of chimneys to a total height of between **1501 and 2000 mm***

(* Los tubos se suministrarán junto con la campana. Indicar claramente "OPCIONAL" en el pedido e indicar la medida exacta de los tubos.

(* The optionals will be supplied together with the cooker hood. Indicate clearly 'OPTIONAL' in the order and indicate the exact size of the chimneys.

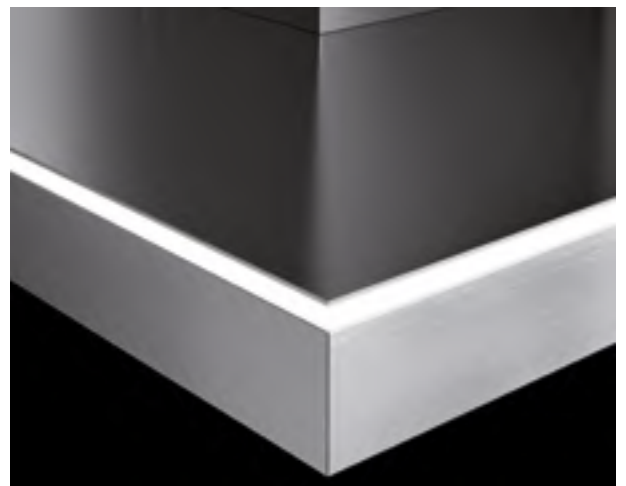



P-417

Notas / Notes

Este modelo solo se suministra en acabado INOX
This model is only supplied in INOX finish

AirClean

Sistema automático de funcionamiento del motor 10 min. cada hora durante 5 horas.
Automatic working motor system for 10 minutes every hour during 5 hours.



Embellecedor a techo
Ceiling trim
Ref. 7118



Mando a distancia
Remote Touch Control
Ref. 620062200478



Incluye Aro reductor de serie
solo para motores V.850
Includes reducer ring as standard
motor only V.850
Ø150 a Ø120 mm

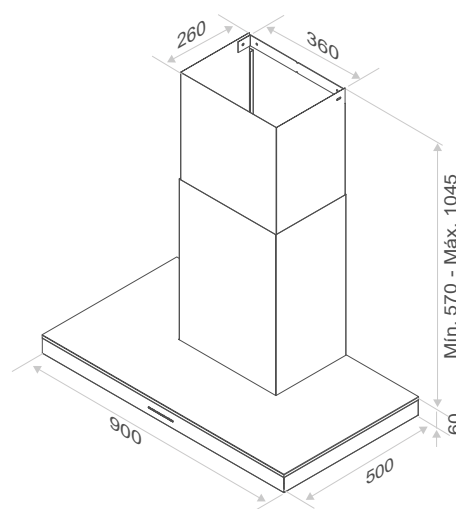

Medidas en / Dimensions in mm
Tubos especiales a medida / Special custom-made chimneys



P-725

Cristal blanco o negro
Black or white glass



Last
TIME

AIR
Clean
24h



Filters
ALU



LED
4500K



GAS
65 cm



IND
50 cm

Opcionales* / Options*



Kits
Recirculation



LED
3000K



Tubos
Chimney



Embell. techo
Ceiling trim.

S.E.C. System®

Motor Interior / Interior Motor

Front. (cm)	Motor	Ø tubo	Clas. Ener.
90	V.850	Ø150	A

Negro / Black

Blanco / White

Kits de recirculación / Activated carbon filters kit:

Front. (cm).	Acabado Finished	Tipo	Ref
90	INOX	FCA	1202646

Opcionales* / Options*

Embellecedor a techo / Ceiling trim. **Ref. 7118**

Opción de cambio de LED original a LED de luz cálida de 3000K.
LED change to warm light LED 3000K. Available only at the factory

Juego de tubos. Altura total hasta **1500 mm***
Set of chimneys to a total height of **1500 mm***

Juego de tubos. Altura total entre **1501 y 2000 mm***
Set of chimneys to a total height of between **1501 and 2000 mm***

Pintado Juegos de tubos en BLANCO o NEGRO
Painted Tube sets in WHITE or BLACK

(*) Los tubos se suministrarán junto con la campana. Indicar claramente "OPCIONAL" en el pedido e indicar la medida exacta de los tubos.

(*) The optionals will be supplied together with the cooker hood. Indicate clearly 'OPTIONAL' in the order and indicate the exact size of the chimneys.



P-725

Notas / Notes

Altura recomendada de instalación desde la zona de cocción a la base de la campana 50 cm.
Para altura mínima 65 cm.

The recommended distance between the base of the hood and cooking area is 50 cm. The minimum distance between the base of the hood and a gas hob is 65 cm.

Recomendada en zonas de cocción compacta de hasta 60 cm.
Recommended for hobs up to 60 cm.

Para un funcionamiento en alto rendimiento es recomendable mantener la puerta de acceso a los filtros abierta.

The filter access door should be kept open for an optimal performance.

Este modelo no tiene posibilidad de salida de humos trasera.
This model does not offer a rear exit option.

Modelo con doble filtración.
Model with double filtering.

Filtro inferior anticondensación
Anti-condensation bottom filter

AirClean

Sistema automático de funcionamiento del motor 10 min. cada hora durante 24 horas.
Automatic working motor system for 10 minutes every hour during 24 hours.



Embellecedor a techo
Ceiling trim
Ref. 7118

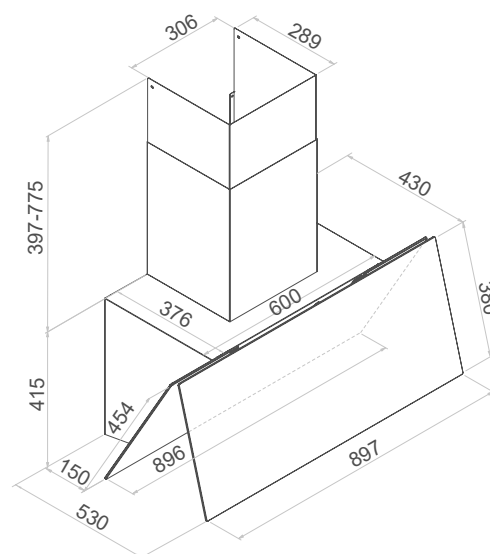

Medidas en / Dimensions in mm
Tubos especiales a medida / Special custom-made chimneys



P-732

Cristal blanco o negro
Black or white glass

70 / 90
cm

SEC
System
PLUS

eco



Last
TIME

AIR
Clean
5h



SIA
Safety



Opcionales* / Options*



AirLink



S.E.C. System® Motor Interior / Interior Motor

Front. (cm)	Motor	Ø tubo	Clas. Ener.
70	V.850	Ø150/120	A+
	V.1050 eco SEC® PLUS	Ø150	A+
90	V.850	Ø150/120	A+
	V.1050 eco SEC® PLUS	Ø150	A+

Negro / Black

Blanco / White

Kits de recirculación / Activated carbon filters kit:

Front. (cm).	Tipo	Ref
70	FCRL-AE	1200573
90	FCRL-AE	1200572

Opcionales* / Options*

AirLink

Modelo compatible. No se equipa de serie. Imprescindible solicitar en pedido.
Compatible Model. Is not included as standard. Must be ordered.

Embellecedor a techo / Ceiling trim. Ref. 7118

Mando a distancia Touch. Suministrado con la campana.
Remote Control Touch supplied together with the hood.

Juego de tubos. Altura total hasta 1500 mm*
Set of chimneys to a total height of 1500 mm*

Juego de tubos. Altura total entre 1501 y 2000 mm*
Set of chimneys to a total height of between 1501 and 2000 mm*

Pintado Juegos de tubos en BLANCO o NEGRO
Painted chimney sets in WHITE or BLACK

(*) Los tubos se suministrarán junto con la campana. Indicar claramente "OPCIONAL" en el pedido e indicar la medida exacta de los tubos.

(*) The optionals will be supplied together with the cooker hood. Indicate clearly 'OPTIONAL' in the order and indicate the exact size of the chimneys.

Notas / Notes

Incorpora de serie motor direccionable que permite la salida de humos vertical o trasera.
Incorporates a controllable motor as standard, allowing for vertical or rear smoke outlet.

Altura recomendada de instalación desde la zona de cocción a la base de la campana 50 cm.
Para altura mínima 65 cm.

The recommended distance between the base of the hood and cooking area is 50 cm.
The minimum distance between the base of the hood and a gas hob is 65 cm.

Recomendada en zonas de cocción compacta de hasta 60 cm.
Recommended for hobs up to 60 cm.

Para un funcionamiento en alto rendimiento es recomendable mantener la puerta de acceso a los filtros abierta.
The filter access door should be kept open for an optimal performance.

AirClean

Sistema automático de funcionamiento del motor 10 min. cada hora durante 5 horas.
Automatic working motor system for 10 minutes every hour during 5 hours.



Model. 90 cm

P-732



Embellecedor a techo
Ceiling trim
Ref. 7118



Mando a distancia
Remote Touch Control
Ref. 620062200478



Incluye Aro reductor de serie
solo para motores V.850
Includes reducer ring as standard
motor only V.850
Ø150 a Ø120 mm

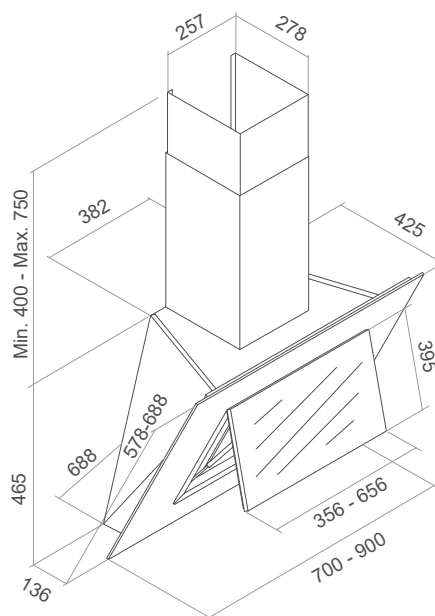

Medidas en / Dimensions in mm
Tubos especiales a medida / Special custom-made chimneys



P-823 N

Inox
Stainless Steel

60 / 70 / 90
cm



Last
TIME

AIR
Clean
5h



LED
4000K



Opcionales* / Options*



LED
3000K



S.E.C. System® Motor Interior / Interior Motor

Front. (cm)	Motor	Ø tubo	Clas. Ener.	Ref.
60	V.830	Ø150/120	A	010848
70	V.830	Ø150/120	A	010849
90	V.830	Ø150/120	A	010850

Opcionales* / Options*

Embellecedor a techo / Ceiling trim. **Ref. 7118**

Opción de cambio de LED original a LED de luz cálida de 3000K.
LED change to warm light LED 3000K. Available only at the factory

Filtro inoxidable. Precio unitario.
Stainless steel filter. Unit price

Juego de tubos. Altura total hasta 1500 mm*
Set of chimneys to a total height of 1500 mm*

Juego de tubos. Altura total entre 1501 y 2000 mm*
Set of chimneys to a total height of between 1501 and 2000 mm*

(*) Los tubos se suministrarán junto con la campana. Indicar claramente "OPCIONAL" en el pedido e indicar la medida exacta de los tubos.

(*) The optionals will be supplied together with the cooker hood. Indicate clearly 'OPTIONAL' in the order and indicate the exact size of the chimneys.

Kits de recirculación / Activated carbon filters kit:

Front. (cm).	Tipo	Ref
60,70,90	FCA	1200230

Notas / Notes

AirClean

Sistema automático de funcionamiento del motor 10 min. cada hora durante 5 horas.
Automatic working motor system for 10 minutes every hour during 5 hours.



Embellecedor a techo
Ceiling trim
Ref. 7118



Incluye Aro reductor de serie
Includes reducer ring as standard
Ø150 a Ø120 mm

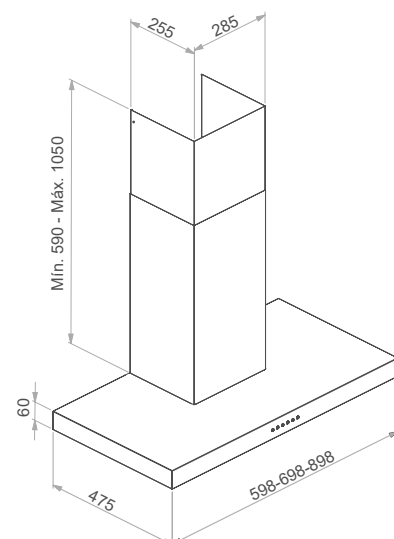

Medidas en / Dimensions in mm
Tubos especiales a medida / Special custom-made chimneys



P-826

Inox con frontal cristal negro
Stainless Steel with black glass front

 90 cm	 Touch	 Last TIME	 AIR Clean 5h	 Filters INOX	Opcionales* / Options*				
 Filters Auto.	 LED 4000K	 SIA Safety	 GAS 65 cm	 Kits Recirculation	 AirLink				
					 Pando LED	 Touch	 Tubos Chimney	 Embell. techo Ceiling trim.	 Filters ECO PLASMA

S.E.C. System® Motor Interior / Interior Motor

Front. (cm)	Motor	Ø tubo	Clas. Ener.	Ref.
90	V.850	Ø150/120	A+	008527

Opcionales* / Options*

AirLink

Modelo compatible. No se equipa de serie. Imprescindible solicitar en pedido.
Compatible Model. Is not included as standard. Must be ordered.

Sistema de filtrado **ECO PLASMA**
ECO PLASMA filter system

Embellecedor a techo / Ceiling trim. **Ref. 7118**

Substitución del LED original por el sistema Pando Led
Change of the original LED to the Pando LED system

Mando a distancia Touch. Suministrado con la campana.
Remote Control Touch supplied together with the hood.

Juego de tubos. Altura total hasta **1500 mm***
Set of chimneys to a total height of **1500 mm***

Juego de tubos. Altura total entre **1501 y 2000 mm***
Set of chimneys to a total height of between **1501 and 2000 mm***

(* Los tubos se suministrarán junto con la campana. Indicar claramente "OPCIONAL" en el pedido e indicar la medida exacta de los tubos.

(* The optionals will be supplied together with the cooker hood. Indicate clearly "OPTIONAL" in the order and indicate the exact size of the chimneys.

Kits de recirculación / Activated carbon filters kit:

Front. (cm).	Tipo	Ref
90	FCRL-AE	1202584

Notas / Notes

AirClean

Sistema automático de funcionamiento del motor 10 min. cada hora durante 5 horas.
Automatic working motor system for 10 minutes every hour during 5 hours.



Embellecedor a techo
Ceiling trim
Ref. 7118



Mando a distancia
Remote Touch Control
Ref. 620062200478



Incluye Aro reductor de serie
Includes reducer ring as standard
Ø150 a Ø120 mm

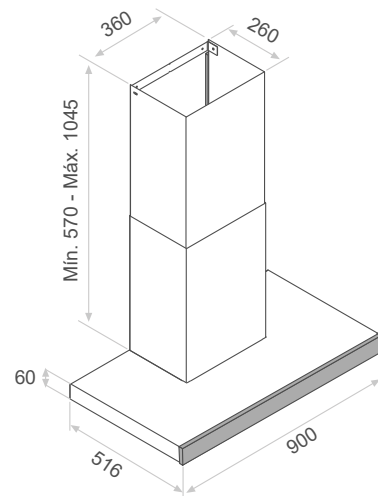

Medidas en / Dimensions in mm
Tubos especiales a medida / Special custom-made chimneys

P-825

Inox, Blanco o Negro
Stainless Steel, White or Black

60 / 70
90 / 120
cm

SEC
System
PLUS



Last
TIME

AIR
Clean
5h



SIA
Safety



Opcionales* / Options*



AirLink



S.E.C. System®

Motor Interior / Interior Motor

Front. (cm)	Motor	Ø tubo	Clas. Ener.
60	V.850	Ø150/120	A+
	V.1050 eco SEC® PLUS	Ø150	A+
70	V.850	Ø150/120	A+
	V.1050 eco SEC® PLUS	Ø150	A+
90	V.850	Ø150/120	A+
	V.1050 eco SEC® PLUS	Ø150	A+
	V.1250 eco	Ø150	A++
120	V.850	Ø150/120	A+
	V.1050 eco SEC® PLUS	Ø150	A+
	V.1250 eco	Ø150	A+

Kits de recirculación / Activated carbon filters kit:

Front. (cm).	Acabado Finished	Tipo	Ref
60	INOX	FCRL-AE	1200233
60	BLANCO	FCRL-AE	1200235
60	NEGRO	FCRL-AE	1200237
70	INOX	FCRL-AE	1202618
70	BLANCO	FCRL-AE	1200593
70	NEGRO	FCRL-AE	1202650
90	INOX	FCRL-AE	1202619
90	BLANCO	FCRL-AE	1202637
90	NEGRO	FCRL-AE	1202651
120	INOX	FCRL-AE	1200239
120	BLANCO	FCRL-AE	1200241
120	NEGRO	FCRL-AE	1200243

Opcionales* / Options*

AirLink

Modelo compatible. No se equipa de serie. Imprescindible solicitar en pedido.
Compatible Model. Is not included as standard. Must be ordered.

Sistema de filtrado ECO PLASMA
ECO PLASMA filter system

Embellecedor a techo / Ceiling trim. Ref. 7118

Substitución del LED original por el sistema Pando Led
Change of the original LED to the Pando LED system

Mando a distancia Touch. Suministrado con la campana.
Remote Control Touch supplied together with the hood.

Juego de tubos INOX. Altura total de 1500 mm*
Set of STAINLESS STEEL chimneys to a total height of 1500 mm*

Juego de tubos INOX. Altura total entre 1501 y 2000 mm*
Set of STAINLESS STEEL chimneys to a total height of between * 1501 and 2000 mm*

Juego de tubos BLANCO/NEGRO SATINADO. Altura total de 1500 mm*
Set of WHITE/BLACK SATIN chimneys to a total height of 1500 mm*

Juego de tubos BLANCO/NEGRO SATINADO. Altura total entre 1501 y 2000 mm*
Set of WHITE/BLACK SATIN chimneys to a total height of between 1501 and 2000 mm*

(*) Los tubos se suministrarán junto con la campana. Indicar claramente "OPCIONAL" en el pedido e indicar la medida exacta de los tubos.

(*) The optionals will be supplied together with the cooker hood. Indicate clearly 'OPTIONAL' in the order and indicate the exact size of the chimneys.



Model. 90 cm

P-825



Embellecedor a techo
Ceiling trim
Ref. 7118



Mando a distancia
Remote Touch Control
Ref. 620062200478



Incluye Aro reductor **de serie**
solo para motores V.850
Includes reducer ring as **standard**
motor only V.850
Ø150 a Ø120 mm

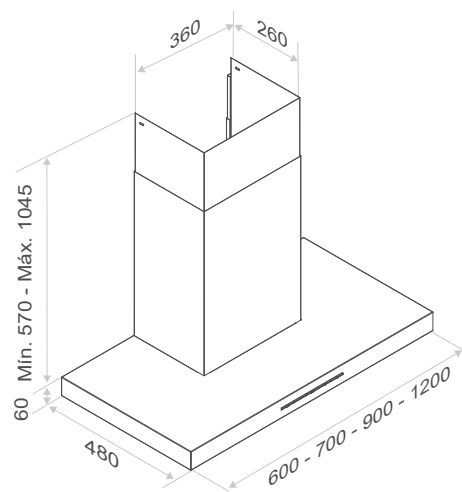

Medidas en / Dimensions in mm
Tubos especiales a medida / Special custom-made chimneys



P-827

Inox con frontal cristal negro
Stainless Steel with black glass front



Last TIME

AIR Clean 5h



SIA Safety



Opcionales* / Options*



Kits Recirculation

AirLink



Touch



Tubos Chimney



Embell. techo Ceiling trim.



Filters ECO PLASMA

S.E.C. System® Motor Interior / Interior Motor

Front. (cm)	Motor	Ø tubo	Clas. Ener.	Ref.
90	V.850	Ø150	A	009934

Kits de recirculación / Activated carbon filters kit:

Front. (cm).	Tipo	Ref
90	FCRL-AE	1202624

Opcionales* / Options*

AirLink

Modelo compatible. No se equipa de serie. Imprescindible solicitar en pedido.
Compatible Model. Is not included as standard. Must be ordered.

Sistema de filtrado **ECO PLASMA**
ECO PLASMA filter system

Embellecedor a techo / Ceiling trim. **Ref. 7118**

Mando a distancia Touch. Suministrado con la campana.
Remote Control Touch supplied together with the hood.

Juego de tubos. Altura total hasta **1500 mm***
Set of chimneys to a total height of **1500 mm***

Juego de tubos. Altura total entre **1501 y 2000 mm***
Set of chimneys to a total height of between **1501 and 2000 mm***

(* Los tubos se suministrarán junto con la campana. Indicar claramente "OPCIONAL" en el pedido e indicar la medida exacta de los tubos.

(* The optionals will be supplied together with the cooker hood. Indicate clearly 'OPTIONAL' in the order and indicate the exact size of the chimneys.



P-827

Notas / Notes

AirClean

Sistema automático de funcionamiento del motor 10 min. cada hora durante 5 horas.
Automatic working motor system for 10 minutes every hour during 5 hours.



Embellecedor a techo
Ceiling trim
Ref. 7118



Mando a distancia
Remote Touch Control
Ref. 620062200478

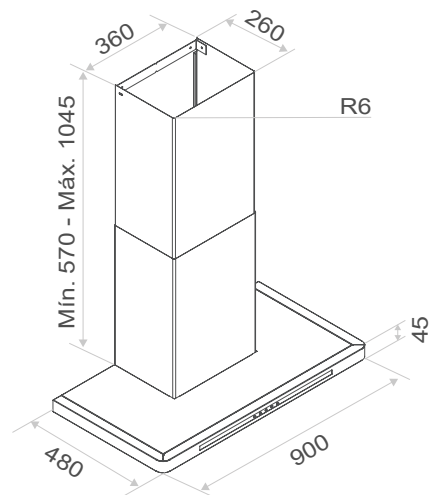

Medidas en / Dimensions in mm
Tubos especiales a medida / Special custom-made chimneys

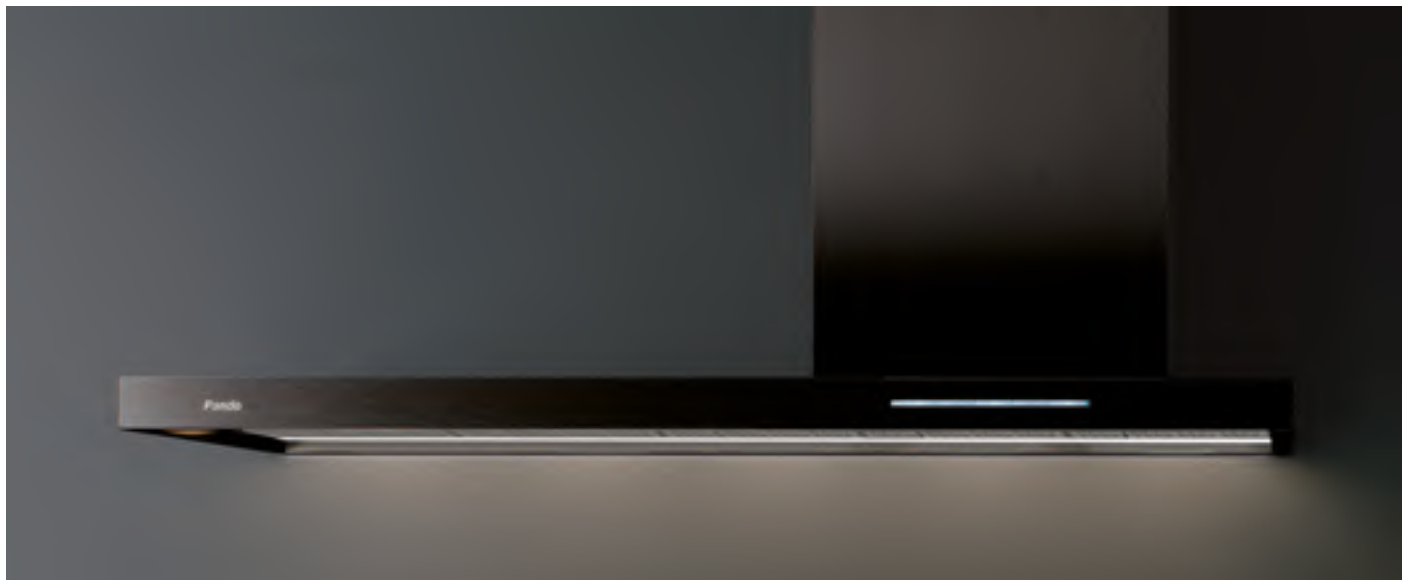

P-842/6 P-842/11

Inox - Realizada a medida
Stainless Steel - Custom made

P-842/6. Altura de 6 cm del cuerpo de la campana.
P-842/6. 6 cm height of cooker hood body

							Opcionales* / Options*		

S.E.C. System®

Motor Interior / Interior Motor

Motor	Ø tubo
V.1050 <i>eco</i> SEC® PLUS	Ø150
V.1250 <i>eco</i>	Ø150
V.2200 <i>eco</i>	Ø200

Motor Intermedio exterior / Duct-in-line motor

V.1550 <i>eco</i>	Ø150
V.2450 <i>eco</i>	Ø200
V.3000 <i>eco</i>	Ø200

Motor de tejado / Remote motor -Roof Outdoor

V.2350 <i>eco</i>	Ø200
V.3300 <i>eco</i>	Ø200

Notas / Notes

Para modelos con carbón activado las medidas de los tubos serán:
The flues will be as follows for models with activated carbon: Min. 645 - Máx. 1045

AirClean

Sistema automático de funcionamiento del motor 10 min. cada hora durante 5 horas.
Automatic working motor system for 10 minutes every hour during 5 hours.

Opcionales* / Options*

AirLink

Modelo compatible. No se equipa de serie. Imprescindible solicitar en pedido.
Compatible Model. Is not included as standard. Must be ordered.

Sistema de filtrado ECO PLASMA
ECO PLASMA filter system

Embellecedor a techo / Ceiling trim. **Ref. 7118**

Mando a distancia Touch. Suministrado con la campana.
Remote Control Touch supplied together with the hood.

Modelo personalizable en cualquier color de la carta RAL. Bajo presupuesto.
Customizable model in any color from the RAL chart. On request.

Enchufes y conectores USB - Bajo presupuesto.
Plugs and USB connectors - On request.

Kits de recirculación - Bajo presupuesto.
Activated carbon filters kit - On request.

(*) Los tubos se suministrarán junto con la campana. Indicar claramente "OPCIONAL" en el pedido e indicar la medida exacta de los tubos.
(* The optionals will be supplied together with the cooker hood. Indicate clearly 'OPTIONAL' in the order and indicate the exact size of the chimneys.



Embellecedor a techo
Ceiling trim
Ref. 7118



Mando a distancia
Remote Touch Control
Ref. 620062200478





P-842/11. Altura de 11 cm del cuerpo de la campana.
 P-842/11. 11 cm height of cooker hood body

P-842/6 P-842/11

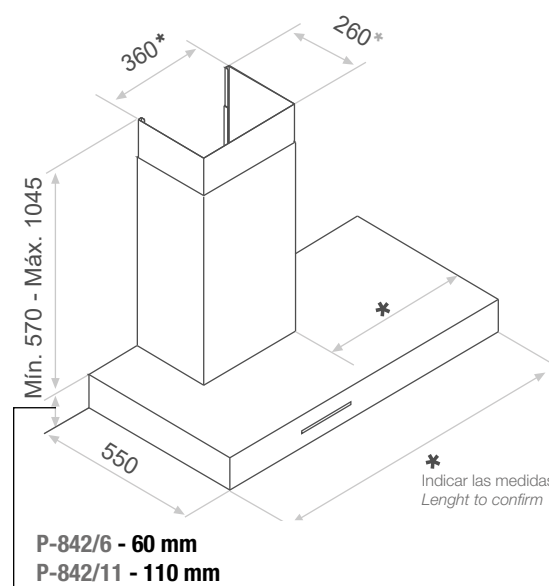

Medidas en / Dimensions in mm

La botonera siempre irá ubicada centrada debajo del tubo de extracción. Por ello, según el tubo se sitúe en la derecha o en la izquierda de la campana, la botonera también variará su posición.

The control panel is always positioned centrally under the extraction chimney. Therefore, depending on whether the chimney is located on the right or left side of the cooker hood, the position of the control panel will also vary.

* Para motores V.2200 ECO, la medida del tubo debe ser 472x330
 For V.2200 ECO motors, the duct size must be 472x330





P-861

Inox - Esmaltado Negro
Stainless Steel - Black enamel

Model. 180 cm

P-861

Inox - Esmaltado Negro
Stainless Steel - Black enamel

90 / 105 / 120
140 / 150 / 180



SEC
System
PLUS



eco

Inox
AISI
304



Last
TIME

AIR
Clean
5h



SIA
Safety



Opcionales* / Options*



AirLink



Kits de recirculación / Activated carbon filters kit:

Front. (cm).	Acabado Finished	Tipo	Ref
90	INOX	FCRL-AE	1200216
105	INOX	FCRL-AE	1202550
120	INOX	FCRL-AE	1200217
140	INOX	FCRL-AE	1202592
150	INOX	FCRL-AE	1202581
180	INOX	FCRL-AE	1202589
90	NEG. SAT.	FCRL-AE	1200244
105	NEG. SAT.	FCRL-AE	1200245
120	NEG. SAT.	FCRL-AE	1200246
140	NEG. SAT.	FCRL-AE	1200247
150	NEG. SAT.	FCRL-AE	1200248
180	NEG. SAT.	FCRL-AE	1200249

S.E.C. System®

Motor Interior / Interior Motor

Front. (cm)	Motor	Ø tubo	Clas. Ener.
90	V.850	Ø150	A
	V.1050 eco SEC® PLUS	Ø150	A
	V.1250 eco	Ø150	A+
105	V.850	Ø150	A
	V.1050 eco SEC® PLUS	Ø150	A
	V.1250 eco	Ø150	A+
120	V.850	Ø150	A
	V.1050 eco SEC® PLUS	Ø150	A
	V.1250 eco	Ø150	A+
140	V.1250 eco	Ø150	A
	V.1250 eco	Ø150	A
150	V.1250 eco	Ø150	A
	V.1250 eco	Ø150	A

Motor Intermedio exterior / Duct-in-line motor

90	V.1550 eco	Ø150	A+
	V.2450 eco	Ø200	A+
105	V.1550 eco	Ø150	A
	V.2450 eco	Ø200	A
120	V.1550 eco	Ø150	A
	V.2450 eco	Ø200	A
140	V.1550 eco	Ø150	A
	V.2450 eco	Ø200	A
150	V.1550 eco	Ø150	A
	V.2450 eco	Ø200	A
180	V.1550 eco	Ø150	A
	V.2450 eco	Ø200	A

Motor de tejado / Remote motor -Roof Outdoor

90	V.2350 eco	Ø200	A+
105	V.2350 eco	Ø200	A
120	V.2350 eco	Ø200	A
140	V.2350 eco	Ø200	A
150	V.2350 eco	Ø200	A
180	V.2350 eco	Ø200	A

Opcionales* / Options*

AirLink

Modelo compatible. No se equipa de serie. Imprescindible solicitar en pedido.
Compatible Model. Is not included as standard. Must be ordered.

Sistema de filtrado ECO PLASMA

ECO PLASMA filter system

Embellecedor a techo / Ceiling trim. Ref. 7118

Mando a distancia Touch. Suministrado con la campana.
Remote Control Touch supplied together with the hood.

Juego de tubos INOX. Altura total de 1500 mm*

Set of STAINLESS STEEL chimneys to a total height of 1500 mm*

Juego de tubos INOX. Altura total entre 1501 y 2000 mm*

Set of STAINLESS STEEL chimneys to a total height of between 1501 and 2000 mm*

Juego de tubos NEGRO SATINADO. Altura total de 1500 mm*

Set of BLACK SATIN chimneys to a total height of 1500 mm*

Juego de tubos NEGRO SATINADO. Altura total entre 1501 y 2000 mm*

Set of BLACK SATIN chimneys to a total height of between 1501 and 2000 mm*

Modelo personalizable en cualquier color de la carta RAL. Bajo presupuesto.
Customizable model in any color from the RAL chart. On request.

(*) Los tubos se suministrarán junto con la campana. Indicar claramente "OPCIONAL" en el pedido e indicar la medida exacta de los tubos.

(*) The optionals will be supplied together with the cooker hood. Indicate clearly 'OPTIONAL' in the order and indicate the exact size of the chimneys.



Sistema BOP aplicado en en todas las medidas.
BOP system in all sizes.

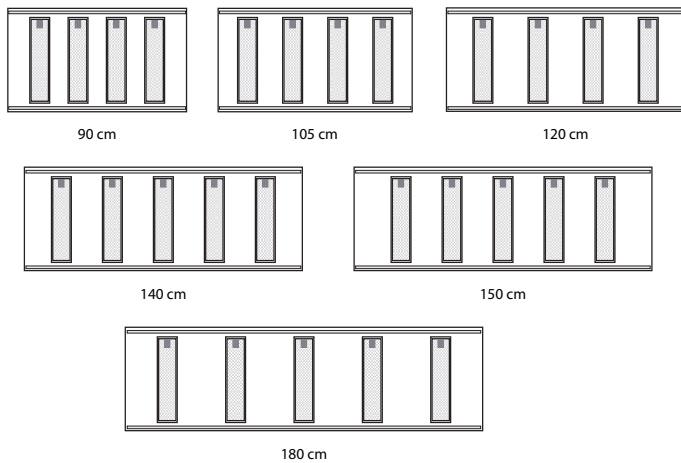

Ejemplo distribución de la bandeja inferior. Para campanas de otras medidas consultar distribución de la bandeja inferior.
Sample bottom tray layout. For hoods in other sizes, consult bottom tray layout.

Notas / Notes

AirClean

Sistema automático de funcionamiento del motor 10 min. cada hora durante 5 horas.
Automatic working motor system for 10 minutes every hour during 5 hours.



Embellecedor a techo
Ceiling trim
Ref. 7118



Mando a distancia
Remote Touch Control
Ref. 620062200478

P-861

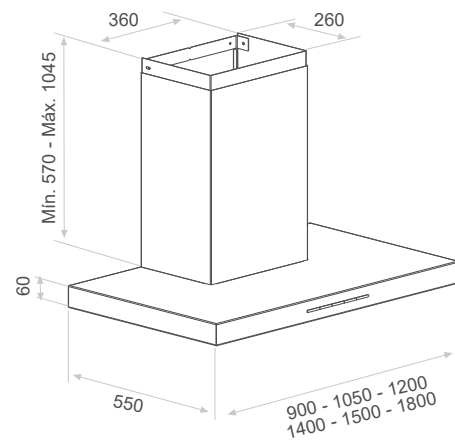

Medidas en / Dimensions in mm
Tubos especiales a medida / Special custom-made chimneys

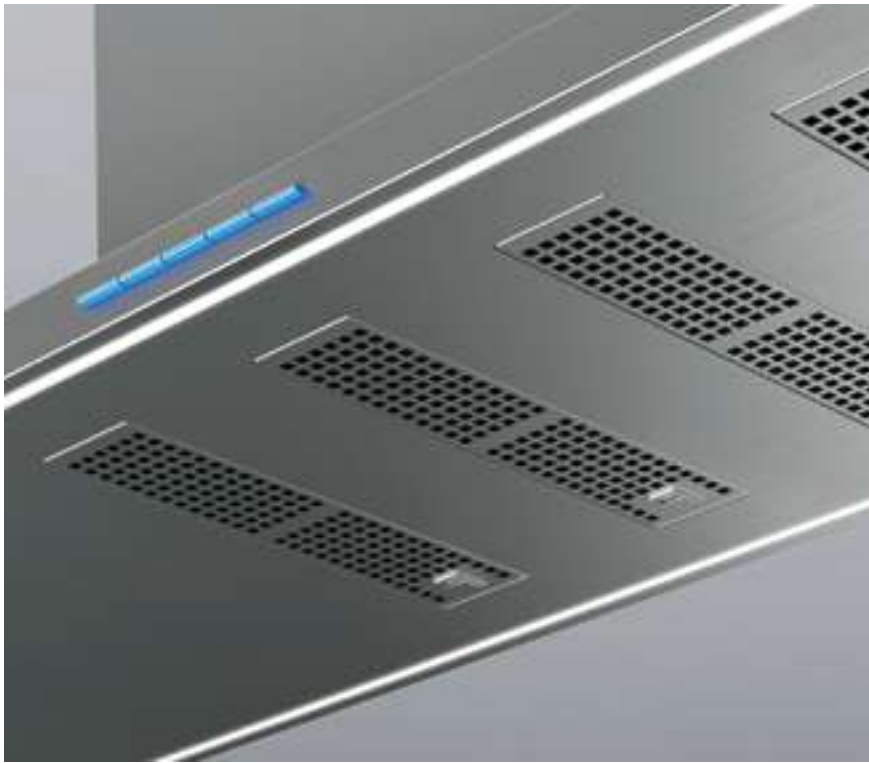

P-898

Inox - Realizada a medida
Stainless Steel - Custom made



eco

Inox
AISI
304



AIR
Clean
5h



SIA
Safety



Opcionales* / Options*



AirLink



S.E.C. System®

Motor Interior / Interior Motor

Motor	Ø tubo
V.1250 eco	Ø150
V.2200 eco	Ø200

Motor Intermedio exterior / Duct-in-line motor

V.1550 eco	Ø150
V.2450 eco	Ø200

Motor de tejado / Remote motor -Roof Outdoor

V.2350 eco	Ø200
------------	------

Opcionales* / Options*

AirLink

Modelo compatible. No se equipa de serie. Imprescindible solicitar en pedido.
Compatible Model. Is not included as standard. Must be ordered.

Sistema de filtrado ECO PLASMA ECO PLASMA filter system

Mando a distancia Touch. Suministrado con la campana.
Remote Control Touch supplied together with the hood.

Modelo personalizable en cualquier color de la carta RAL. Bajo presupuesto.
Customizable model in any color from the RAL chart. On request.

Enchufes y conectores USB - Bajo presupuesto.
Plugs and USB connectors - On request.

Kits de recirculación - Bajo presupuesto. Activated carbon filters kit - On request.

(*) Los tubos se suministrarán junto con la campana. Indicar claramente "OPCIONAL" en el pedido e indicar la medida exacta de los tubos.

(*) The optionals will be supplied together with the cooker hood. Indicate clearly 'OPTIONAL' in the order and indicate the exact size of the chimneys.



Negro satinado
Black satin

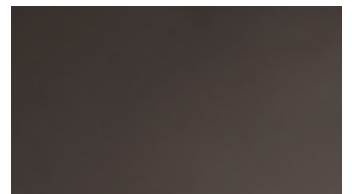

Negro mate RAL 9005
Black mat RAL 9005



Model. 180 cm

P-898

Opción de 1 o 2 racks Option of 1 or 2 racks

* Para motor V.2200 ECO, la medida del tubo debe ser 472x330.
For V.2200 ECO motor, the tube size must be 472x330.

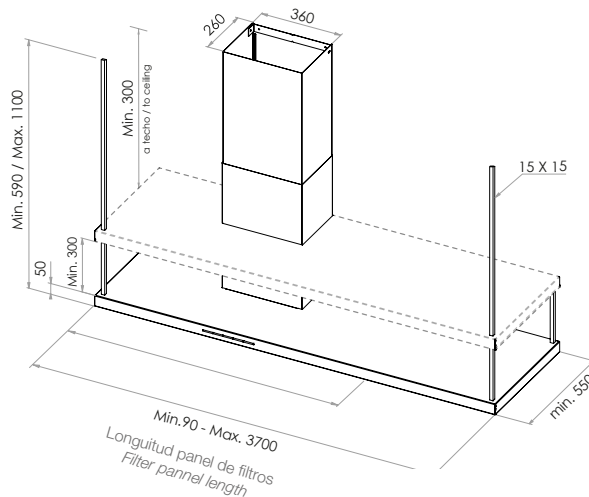

Medidas en / Dimensions in mm

Notas / Notes

Inox esmaltado con color de la carta RAL. Colección especial en negro 9005
Enamel Stainless steel from RAL color Chart. Special collection in black 9005

AirClean

Sistema automático de funcionamiento del motor 10 min. cada hora durante 5 horas.
Automatic working motor system for 10 minutes every hour during 5 hours.



Embellecedor a techo
Ceiling trim
Ref. 7118

Mando a distancia
Remote Touch Control
Ref. 620062200478



P-1001

Inox
Stainless Steel

Opcionales* / Options*

Motor Interior / Interior Motor

Front. (cm)	Motor	Ø tubo	Clas. Ener.	Ref.
90	V.1050 eco SEC® PLUS	Ø150	A++	009406
	V.1250 eco	Ø150	A++	008531
	V.2200 eco	Ø200	A	010232
120	V.1050 eco SEC® PLUS	Ø150	A++	009412
	V.1250 eco	Ø150	A++	008541
	V.2200 eco	Ø200	A	010233

Kits de recirculación / Activated carbon filters kit:

Difusor de techo / Ceiling diffuser:

Descripción	Medidas encastre	Ref
Difusor INOX Techo CON FL. Cerámico	165 x 665 mm	009920
Difusor BLANCO Techo CON FL. Cerámico	165 x 665 mm	009960

Difusor para cornisa / Cornice diffuser:

Descripción	Medidas encastre	Ref
Difusor ALUMINIO Cornisa CON FL. Cerámico	410 x 108 mm	010653
Difusor BLANCO Cornisa CON FL. Cerámico	410 x 108 mm	010655

Opcionales* / Options*

AirLink

Modelo compatible. No se equipa de serie. Imprescindible solicitar en pedido.
Compatible Model. Is not included as standard. Must be ordered.

Embellecedor a techo / Ceiling trim. **Ref. 7118**

Mando a distancia Touch. Suministrado con la campana.
Remote Control Touch supplied together with the hood.

Juego de tubos. Altura total hasta 1500 mm*
Set of chimneys to a total height of 1500 mm*

Juego de tubos. Altura total entre 1501 y 2000 mm*
Set of chimneys to a total height of between 1501 and 2000 mm*

Modelo personalizable en cualquier color de la carta RAL. Bajo presupuesto.
Customizable model in any color from the RAL chart. On request.



(*) Los tubos se suministrarán junto con la campana. Indicar claramente "OPCIONAL" en el pedido e indicar la medida exacta de los tubos.

(*) The optionals will be supplied together with the cooker hood. Indicate clearly "OPTIONAL" in the order and indicate the exact size of the chimneys.



Model. 120 cm

P-1001

Notas / Notes

Incorpora exclusivamente opción de recirculación mediante difusor a techo con filtro cerámico.
It exclusively incorporates the recirculation option by means of ceiling diffuser with ceramic filter.

Incorpora bandeja de fácil limpieza que recoge las grasas de la cocción.
Includes easy-cleaning tray for collection of oil.

Medidas especiales bajo presupuesto.
Custom-made sizes on request.

AirClean

Sistema automático de funcionamiento del motor 10 min. cada hora durante 5 horas.
Automatic working motor system for 10 minutes every hour during 5 hours.



Embellecedor a techo
Ceiling trim
Ref. 7118



Mando a distancia
Remote Touch Control
Ref. 620062200478

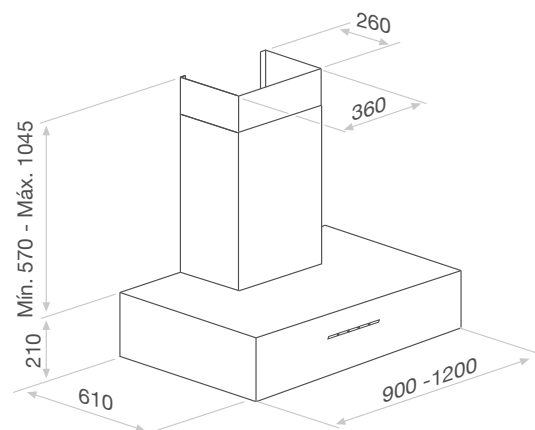

Opcional a medida.
Can be custom made.

Medidas en / Dimensions in mm
Tubos especiales a medida / Special custom-made chimneys

* Para motor V.2200 ECO, la medida del tubo debe ser 472x330.
For V.2200 ECO motor, the chimney size must be 472x330.



P-2000 Model. 120 cm

P-2000

Inox - Opción de realizarla a medida
Stainless Steel - Can be custom made

P-2000 VINTAGE

Cobre - Opción de realizarla a medida
Copper - Can be custom made

							Opcionales* / Options*	

P-2000 - Inox / Stainless Steel

S.E.C. System® Motor Interior / Interior Motor

Front. (cm)	Motor	Ø tubo	Clas. Ener.	Ref.
100	V.1050	Ø150		009738
	V.1250	Ø150		009740
120	V.1050	Ø150		009739
	V.1250	Ø150		009741

P-2000 VINTAGE - Cobre / Copper

S.E.C. System® Motor Interior / Interior Motor

Front. (cm)	Motor	Ø tubo	Clas. Ener.	Ref.
100	V.1050	Ø150		009853
	V.1250	Ø150		009854
120	V.1050	Ø150		009855
	V.1250	Ø150		009856

Opcionales* / Options*

AirLink

Modelo compatible. No se equipa de serie. Imprescindible solicitar en pedido.
Compatible Model. Is not included as standard. Must be ordered.

Embellecedor a techo / Ceiling trim. **Ref. 7118**

Mando a distancia Touch. Suministrado con la campana.
Remote Control Touch supplied together with the hood.

Salida trasera. Indicar en pedido / Specify on order in the case of rear exit.

Juego de tubos. Altura total hasta 1500 mm* (P-2000)
Set of chimneys to a total height of 1500 mm* (P-2000)

Juego de tubos. Altura total entre 1501 y 2000 mm* (P-2000)
Set of chimneys to a total height of between 1501 and 2000 mm* (P-2000)

Juego de tubos. Altura total hasta 1500 mm* (P-2000 Vintage)
Set of chimneys to a total height of 1500 mm* (P-2000 Vintage)

Juego de tubos. Altura total entre 1501 y 2000 mm* (P-2000 Vintage)
Set of chimneys to a total height of between 1501 and 2000 mm* (P-2000 Vintage)

Modelo personalizable en cualquier color de la carta RAL. Bajo presupuesto.
Customizable model in any color from the RAL chart. On request.

(* Los tubos se suministrarán junto con la campana. Indicar claramente "OPCIONAL" en el pedido e indicar la medida exacta de los tubos.

(* The optionals will be supplied together with the cooker hood. Indicate clearly 'OPTIONAL' in the order and indicate the exact size of the chimneys.



Embellecedor a techo
Ceiling trim
Ref. 7118



Mando a distancia
Remote Touch Control
Ref. 620062200478



P-2000 VINTAGE Model. 120 cm

P-2000 / P-2000 VINTAGE

Kits de recirculación / Activated carbon filters kit:

Difusor para techo filtro cerámico / Ceiling diffuser ceramic filter

Descripción	Medidas encastre	Ref
Inox / Stainless Steel	410 x 108 mm	009920
Blanco / White	410 x 108 mm	009960

Difusor para cornisa filtro cerámico / Cornice diffuser ceramic filter

Descripción	Medidas encastre	Ref.
Aluminio / Aluminium	410 x 108 mm	010653
Blanco / White	410 x 108 mm	010655



Notas / Notes

Incorpora exclusivamente opción de recirculación mediante difusor a techo con filtro cerámico.
It exclusively incorporates the recirculation option by means of ceiling diffuser with ceramic filter.

Incorpora bandeja de fácil limpieza que recoge las grasas de la cocción.
Includes easy-cleaning tray for collection of oil.

Medidas especiales bajo presupuesto.
Custom-made sizes on request.

AirClean

Sistema automático de funcionamiento del motor 10 min. cada hora durante 5 horas.
Automatic working motor system for 10 minutes every hour during 5 hours.

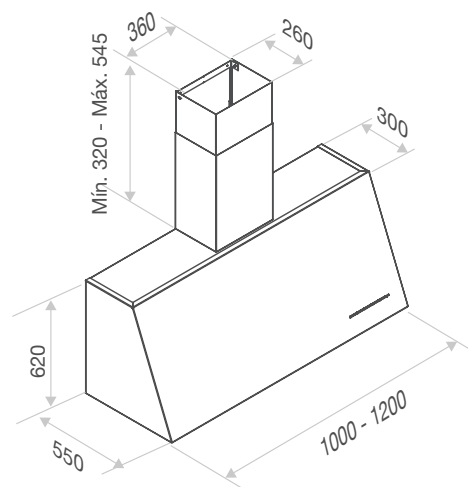

Opcional a medida.
Can be custom made.

Medidas en / Dimensions in mm
Tubos especiales a medida / Special custom-made chimneys





Model. 120 cm

P-2010

Inox, Cobre, Oro, Blanco RAL 9003,
Negro Mate, Negro satinado
Stainless Steel, Copper or Luxury Gold
White RAL 9003, Black Matt, Satin Black





P-2010

Inox, Cobre, Oro, Blanco RAL 9003, Negro Mate, Negro satinado
Stainless Steel, Copper or Luxury Gold, White RAL 9003, Black
Matt, Satin Black

Opcionales* / Options* **AirLink**

--	--	--	--

Opcionales* / Options*

AirLink

Modelo compatible. No se equipa de serie. Imprescindible solicitar en pedido.
Compatible Model. Is not included as standard. Must be ordered.

Sistema de filtrado **ECO PLASMA**
ECO PLASMA filter system

Embellecedor a techo / Ceiling trim. **Ref. 7118**

Mando a distancia Touch. Suministrado con la campana.
Remote Control Touch supplied together with the hood.

Salida trasera. Indicar en pedido.
Specify on order in the case of rear exit.

Juego de tubos **INOX**. Altura total de **1500 mm***
Set of **STAINLESS STEEL** chimneys to a total height of **1500 mm***

Juego de tubos **INOX**. Altura total entre **1501 y 2000 mm***
Set of **STAINLESS STEEL** chimneys to a total height of between **1501 and 2000 mm***

Juego de tubos **ORO/COBRE**. Altura total de **1500 mm***
Set of **GOLD/COPPER** chimneys to a total height of **1500 mm***

Juego de tubos **ORO/COBRE**. Altura total entre **1501 y 2000 mm***
Set of **GOLD/COPPER** chimneys to a total height of between **1501 and 2000 mm***

Juego de tubos **BLANCO/NEGRO**. Altura total de **1500 mm***
Set of **WHITE/BLACK** chimneys to a total height of **1500 mm***

Juego de tubos **BLANCO/NEGRO**. Altura total entre **1501 y 2000 mm***
Set of **WHITE/BLACK** chimneys to a total height of between **1501 and 2000 mm***

Modelo personalizable en cualquier color de la carta RAL. Bajo presupuesto.
Customizable model in any color from the RAL chart. On request.

(* Los tubos se suministrarán junto con la campana. Indicar claramente "OPCIONAL" en el pedido e indicar la medida exacta de los tubos.

(* The optionals will be supplied together with the cooker hood. Indicate clearly 'OPTIONAL' in the order and indicate the exact size of the chimneys.

S.E.C. System®

Motor Interior / Interior Motor

Inox / Stainless Steel

Front. (cm)	Motor	Ø tubo	Clas. Ener.	Ref.
90	V.850	Ø150	A++	009860
	V.1050 <i>eco</i>	Ø150	A++	009861
	V.1250 <i>eco</i>	Ø150	A++	009862
120	V.850	Ø150	A++	009878
	V.1050 <i>eco</i>	Ø150	A++	009879
	V.1250 <i>eco</i>	Ø150	A++	009880

Negro mate RAL 9005 / RAL 9005 Black matt

90	V.850	Ø150	A++	009869
	V.1050 <i>eco</i>	Ø150	A++	009870
	V.1250 <i>eco</i>	Ø150	A++	009871
120	V.850	Ø150	A++	009887
	V.1050 <i>eco</i>	Ø150	A++	009888
	V.1250 <i>eco</i>	Ø150	A++	009889

Negro satinado / Satin black

90	V.850	Ø150	A++	009872
	V.1050 <i>eco</i>	Ø150	A++	009873
	V.1250 <i>eco</i>	Ø150	A++	009874
120	V.850	Ø150	A++	009890
	V.1050 <i>eco</i>	Ø150	A++	009891
	V.1250 <i>eco</i>	Ø150	A++	009892

Blanco / White RAL 9003

90	V.850	Ø150	A++	009942
	V.1050 <i>eco</i>	Ø150	A++	009943
	V.1250 <i>eco</i>	Ø150	A++	009944
120	V.850	Ø150	A++	009945
	V.1050 <i>eco</i>	Ø150	A++	009946
	V.1250 <i>eco</i>	Ø150	A++	009947

Cobre / Luxury Copper

90	V.850	Ø150	A++	009863
	V.1050 <i>eco</i>	Ø150	A++	009864
	V.1250 <i>eco</i>	Ø150	A++	009865
120	V.850	Ø150	A++	009881
	V.1050 <i>eco</i>	Ø150	A++	009882
	V.1250 <i>eco</i>	Ø150	A++	009883

Oro / Luxury Gold

90	V.850	Ø150	A++	009866
	V.1050 <i>eco</i>	Ø150	A++	009867
	V.1250 <i>eco</i>	Ø150	A++	009868
120	V.850	Ø150	A++	009884
	V.1050 <i>eco</i>	Ø150	A++	009885
	V.1250 <i>eco</i>	Ø150	A++	009886



P-2010

Kits de recirculación / Activated carbon filters kit:

Front. (cm).	Acabado Finished	Tipo	Ref
90	INOX	FCRL-AE	1200220
90	COBRE	FCRL-AE	1200580
90	ORO	FCRL-AE	1200582
90	NEGRO MATE	FCRL-AE	1200584
90	NEGRO SATINADO	FCRL-AE	1200588
90	BLANCO	FCRL-AE	1200590
120	INOX	FCRL-AE	1200221
120	COBRE	FCRL-AE	1200581
120	ORO	FCRL-AE	1200583
120	NEGRO MATE	FCRL-AE	1200585
120	NEGRO SATINADO	FCRL-AE	1200589
120	BLANCO	FCRL-AE	1200591

Notas / Notes

AirClean

Sistema automático de funcionamiento del motor 10 min. cada hora durante 5 horas.
Automatic working motor system for 10 minutes every hour during 5 hours.



Embellecedor a techo
Ceiling trim
Ref. 7118



Mando a distancia
Remote Touch Control
Ref. 620062200478

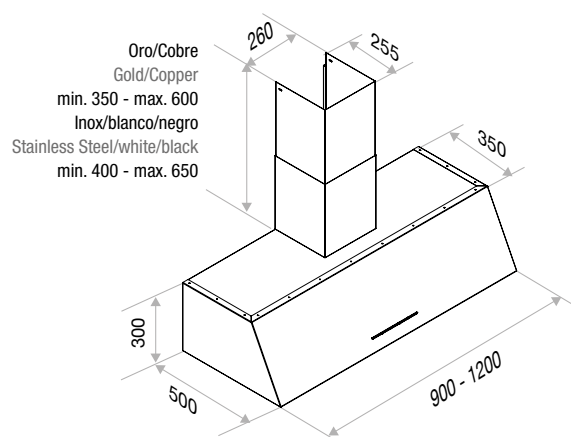

Medidas en / Dimensions in mm
Tubos especiales a medida / Special custom-made chimneys



**CAMPANAS
DE ISLA**

**COOKER
HOODS
ISLAND**

I-300
p.152

I-330
p.152

I-825
p.154

I-861
p.156



I-894
Modular
p.158



I-875
p.150



I-897
Cristal
Glass
p.160

I-898
p.162

I-1300
p.166

SKYLOOP
p.168



DEKTON®
LAURENT

DEKTON®
AERIS

DEKTON®
KELIA

DEKTON®
TRILIUM

DEKTON®
ZENIT

DEKTON®
REVERIE

I-875

Esmaltado Negro satinado, carta RAL o DEKTON
Enamelled in satin black, RAL color Chart or DEKYON



eco



Elect.

Last
TIME

AIR
Clean
5h



tunable



Touch



Pando
WiFi

Opcionales* / Options*



Filters
INOX



Filters
FCFR



Filters
Auto.



LED
3000K
4000K

SIA
Safety



GAS
65 cm



RAL

AirLink

Campana totalmente personalizable tanto en color como en la medida del frontal
Fully customizable Cooker Hood in both color and in the size of the front

Ancho máximo de la zona de cocción recomendable: 60 cm.
Maximum recommended cooking zone width: 60 cm.

Medidas especiales bajo estudio
Special sizes on request.

Colección especial en color negro satinado
Special collection in black satin color



Opcionales* / Options*

AirLink

Modelo compatible. No se equipa de serie. Imprescindible solicitar en pedido.
Compatible Model. Is not included as standard. Must be ordered.

(*) Los opcionales se suministrarán junto con la campana. Indicar claramente "OPCIONAL" en el pedido e introducir los datos de forma clara.

(*) The optionals will be supplied together with the cooker hood. Indicate clearly 'OPTIONAL' in the order and enter the data clearly.

Notas / Notes

AirClean

Sistema automático de funcionamiento del motor 10 min. cada hora durante 5 horas.
Automatic working motor system for 10 minutes every hour during 5 hours.



Model. 180 cm



I-875

Modelo exclusivo de recirculación
Exclusive recirculation model

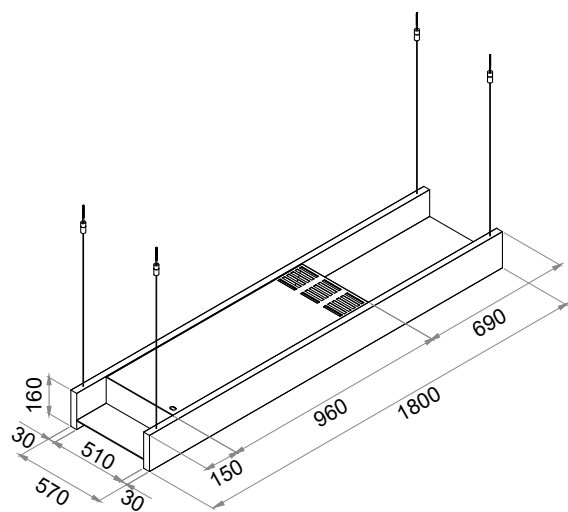

Medidas en / Dimensions in mm



Mando a distancia
 Remote Touch Control
 Ref. 620062200478



I-300
Inox
Stainless Steel

I-330
Cristal - Touch Control
Glass - Touch control



I-300
Model. 130 cm



eco

Inox
AISI
304



Last
TIME

AIR
Clean
5h



Filters
INOX



SIA
Safety



Opcionales* / Options*



AirLink



S.E.C. System®
Interior / Interior

Motor	Ø tubo
V.1250 <i>eco</i>	Ø150
V.2200 <i>eco</i>	Ø200
Intermedio exterior / Duct-in-line motor	
V.1550 <i>eco</i>	Ø150
V.2450 <i>eco</i>	Ø200
V.3000 <i>eco</i>	Ø200
De tejado / Remote motor -Roof Outdoor	
V.2350 <i>eco</i>	Ø200
V.3300 <i>eco</i>	Ø200

Opcionales* / Options*

AirLink

Modelo compatible. No se equipa de serie. Imprescindible solicitar en pedido.
Compatible Model. Is not included as standard. Must be ordered.

Sistema de filtrado **ECO PLASMA**
ECO PLASMA filter system

Embellecedor a techo / Ceiling trim.

Mando a distancia Touch. Suministrado con la campana.
Remote Control Touch supplied together with the hood.

Modelo personalizable en cualquier color de la carta RAL. Bajo presupuesto.
Customizable model in any color from the RAL chart. On request.

Soporte falso techo. Indicar medida del falso techo al techo real. Bajo presupuesto.
False Ceiling Support. Specified sizes from ceiling to concrete ceiling. On request.

(* Los opcionales se suministrarán junto con la campana. Indicar claramente "OPCIONAL" en el pedido e introducir los datos de forma clara.

(* The optionals will be supplied together with the cooker hood. Indicate clearly 'OPTIONAL' in the order and enter the data clearly.



I-300 / I-330

Soporte falso techo opcional/ Optional false ceiling support.

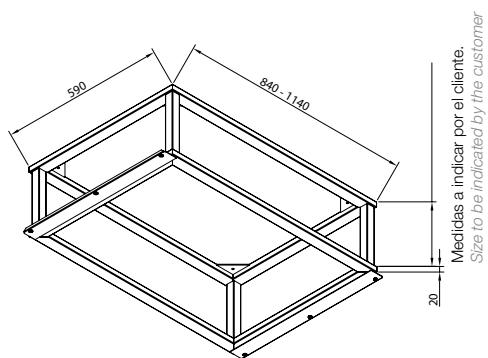

Notas / Notes

I-330

Botonera TOUCH únicamente en acabados blanco o negro brillo.
Resto de colores, incorporan botonera electrónica + Last Time en zona inferior.
TOUCH control only in glossy black or white finish. The rest of the colours incorporate electronic control + Last Time in lower section.

AirClean

Exclusivo para el modelo I-330
Sistema automático de funcionamiento del motor 10 min. cada hora durante 5 horas.
Automatic working motor system for 10 minutes every hour during 5 hours.



Mando a distancia
Remote Touch Control
Ref. 620062200478

**Fabricadas a medida.
Custom Made.**

Altura mínima para campanas especiales 500 mm.
Para modelo de recirculación, altura mínima de 700 mm.
Minimum height for special hoods 500 mm.

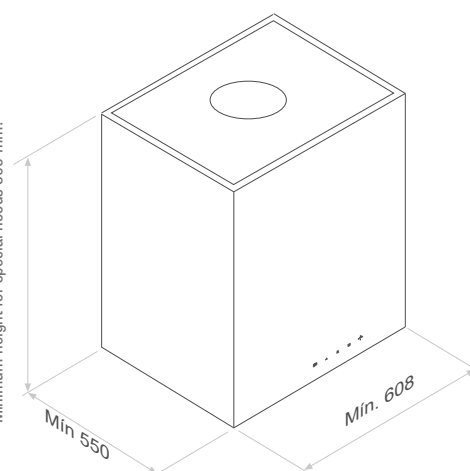

Medidas en / Dimensions in mm



Model. 90 cm

I-825

Inox - Negro satinado
Stainless Steel - Satin black

90 / 120 cm

eco

Elect.

Last TIME

AIR Clean 5h

Pando Wi-Fi

Pando LED

Filters INOX

Filters Auto.

SIA Safety

GAS 65 cm

RAL

Opcionales* / Options*

Kits Recirculation

AirLink

Touch

Tubos Chimney

Filters ECO PLASMA

S.E.C. System®

Motor Interior / Interior Motor

Front. (cm)	Motor	Ø tubo	Clas. Ener.	Ref.
-------------	-------	--------	-------------	------

Inox / Stainless Steel

90	V.850	Ø150	A+	007602
	V.1250 eco	Ø150	A+	008442
120	V.1250 eco	Ø150	A+	009021

Negro satinado / Satin black

90	V.850	Ø150	A+	010111
	V.1250 eco	Ø150	A+	010112
120	V.1250 eco	Ø150	A+	010113

Kits de recirculación / Activated carbon filters kit:

Front. (cm).	Acabado Finished	Tipo	Ref
90	INOX	FCRL-AE	1200222
90	NEGRO	FCRL-AE	1202653
120	INOX	FCRL-AE	1200223
120	NEGRO	FCRL-AE	1202655

Opcionales* / Options*

AirLink

Modelo compatible. No se equipa de serie. Imprescindible solicitar en pedido.
Compatible Model. Is not included as standard. Must be ordered.

Sistema de filtrado ECO PLASMA

ECO PLASMA filter system

Mando a distancia Touch. Suministrado con la campana.
Remote Control Touch supplied together with the hood.

Juego de tubos INOX. Altura total de 1500 mm*

Set of STAINLESS STEEL chimneys to a total height of 1500 mm*

Juego de tubos INOX. Altura total entre 1501 y 2000 mm*

Set of STAINLESS STEEL chimneys to a total height of between 1501 and 2000 mm*

Juego de tubos NEGRO SATINADO. Altura total de 1500 mm*

Set of BLACK SATIN chimneys to a total height of 1500 mm*

Juego de tubos NEGRO SATINADO. Altura total entre 1501 y 2000 mm*

Set of BLACK SATIN chimneys to a total height of between 1501 and 2000 mm*

Modelo personalizable en cualquier color de la carta RAL. Bajo presupuesto.
Customizable model in any color from the RAL chart. On request.

Soporte falso techo regulable

Adjustable false ceiling support

(* Los opcionales se suministrarán junto con la campana. Indicar claramente "OPCIONAL" en el pedido e introducir los datos de forma clara.

(* The optionals will be supplied together with the cooker hood. Indicate clearly 'OPTIONAL' in the order and enter the data clearly.



Model. 90 cm

I-825

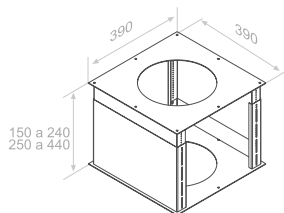

Soporte falso techo regulable
Adjustable false ceiling support

De 150 a 240 mm. Ref. 3589

De 250 a 440 mm. Ref. 3590

Notas / Notes

AirClean

Sistema automático de funcionamiento del motor 10 min. cada hora durante 5 horas.
Automatic working motor system for 10 minutes every hour during 5 hours.



Mando a distancia
Remote Touch Control
Ref. 620062200478

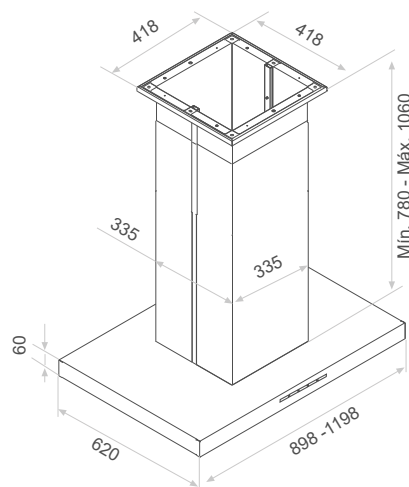

Medidas en / Dimensions in mm
Tubos especiales a medida / Special custom-made chimneys



I-861

Inox - Esmaltado Negro Satinado
Stainless Steel - Saton Black enamel

							Opcionales* / Options*				

S.E.C. System®

Motor Interior / Interior Motor

Front. (cm)	Motor	Ø tubo	Clas. Ener.
90	V.1250	Ø150	
120	V.1250	Ø150	

Motor Intermedio exterior

Duct-in-line motor

90	V.1550	Ø150	
	V.2450	Ø200	
120	V.1550	Ø150	
	V.2450	Ø200	

Motor de tejado

Remote motor -Roof Outdoor

90	V.2350	Ø200	
120	V.2350	Ø200	

(*) Los opcionales se suministrarán junto con la campana. Indicar claramente "OPCIONAL" en el pedido e introducir los datos de forma clara.

(*) The optionals will be supplied together with the cooker hood. Indicate clearly 'OPTIONAL' in the order and enter the data clearly.

Opcionales* / Options*

AirLink

Modelo compatible. No se equipa de serie. Imprescindible solicitar en pedido.
Compatible Model. Is not included as standard. Must be ordered.

Sistema de filtrado ECO PLASMA ECO PLASMA filter system

Mando a distancia Touch. Suministrado con la campana.
Remote Control Touch supplied together with the hood.

Juego de tubos INOX. Altura total de 1500 mm*
Set of STAINLESS STEEL chimneys to a total height of 1500 mm*

Juego de tubos INOX. Altura total entre 1501 y 2000 mm*
Set of STAINLESS STEEL chimneys to a total height of between 1501 and 2000 mm*

Juego de tubos NEGRO SATINADO. Altura total de 1500 mm*
Set of BLACK SATIN chimneys to a total height of 1500 mm*

Juego de tubos NEGRO SATINADO. Altura total entre 1501 y 2000 mm*
Set of BLACK SATIN chimneys to a total height of between 1501 and 2000 mm*

Soporte falso techo regulable
Adjustable false ceiling support

Kits de recirculación / Activated carbon filters kit:

Front. (cm).	Acabado Finished	Tipo	Ref
90	INOX	FCRL-AE	1200214
90	NEGRO	FCRL-AE	1200579
120	INOX	FCRL-AE	1202536
120	NEGRO	FCRL-AE	1200578



Model. 120 cm

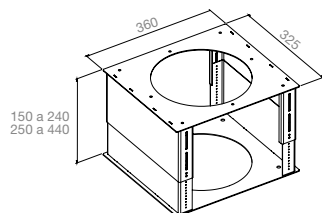

Soporte falso techo regulable
Adjustable false ceiling support

De 150 a 240 mm. Ref. 10520

De 250 a 440 mm. Ref. 10521

Sistema BOP en todas las medidas
BOP system in all sizes

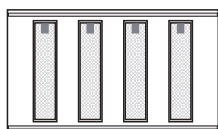

90 cm

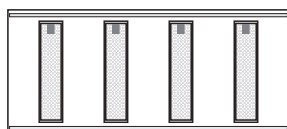

120 cm

Ejemplo distribución de la bandeja inferior. Para campanas de otras medidas consultar distribución de la bandeja inferior.
Sample bottom tray layout. For hoods in other sizes, consult bottom tray layout.

Notas / Notes

Consultar otras medidas disponibles, precio y plazo de entrega
See other sizes available, price and delivery time

AirClean

Sistema automático de funcionamiento del motor 10 min. cada hora durante 5 horas.
Automatic working motor system for 10 minutes every hour during 5 hours.



Embellecidor a techo
Ceiling trim
Ref. 7118



Mando a distancia
Remote Touch Control
Ref. 620062200478

I-861

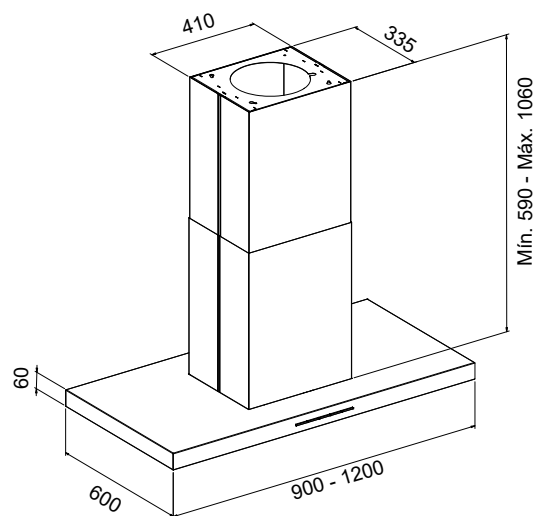

Medidas en / Dimensions in mm
Tubos especiales a medida / Special custom-made chimneys

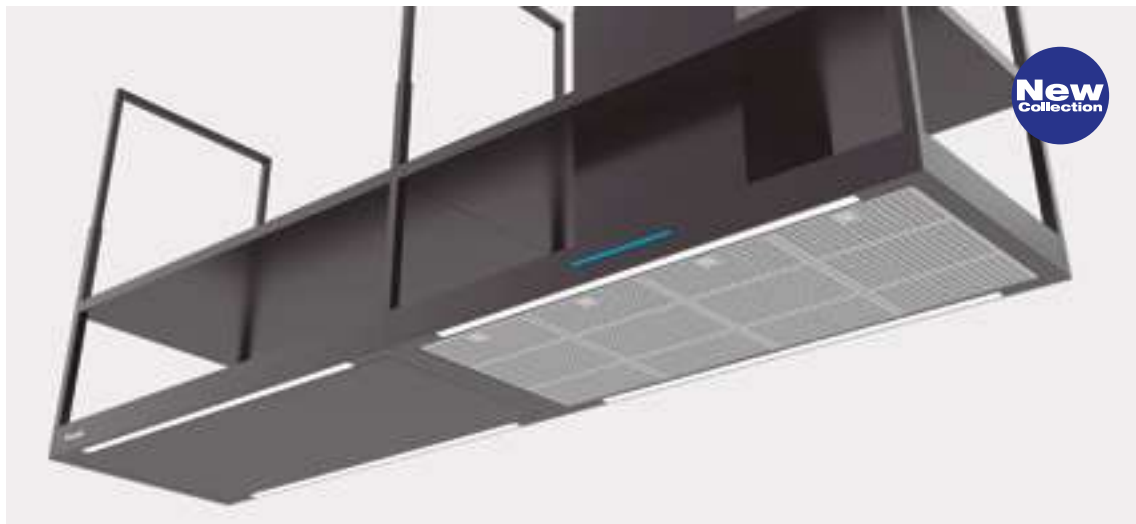

I-894 Modular

Esmaltado negro mate o carta RAL
Enamelled in mat black or RAL color chart

90 / 120
cm

Elect.

Last
TIME

AIR
Clean
5h

Pando
LED

Filters
INOX

Filters
Auto.

SIA
Safety

GAS
65 cm

RAL

Opcionales* / Options*



AirLink



S.E.C. System® Motor Interior / Interior Motor

Campana Cooker hood Front. (cm)	Mod. Decorativ. Front. (cm)	Posición módulo decorativo	Motor	Ø tubo	Clas. Ener.	Ref.
90 1 rack	90	Der./Right	V.850	Ø150	A	010803
			V.1250 eco	Ø150	A+	010804
	120	Izq./Left	V.850	Ø150	A	010805
			V.1250 eco	Ø150	A+	010806
		Der./Right	V.850	Ø150	A	010807
			V.1250 eco	Ø150	A+	010808
90 Doble rack	90	Izq./Left	V.850	Ø150	A	010809
			V.1250 eco	Ø150	A+	010810
	120	Der./Right	V.850	Ø150	A	010819
			V.1250 eco	Ø150	A+	010820
		Izq./Left	V.850	Ø150	A	010821
			V.1250 eco	Ø150	A+	010822
120 1 rack	90	Der./Right	V.850	Ø150	A	010824
			V.1250 eco	Ø150	A+	010825
	120	Izq./Left	V.850	Ø150	A	010826
			V.1250 eco	Ø150	A+	010827
		Der./Right	V.850	Ø150	A	010811
			V.1250 eco	Ø150	A+	010812
120 Doble rack	90	Izq./Left	V.850	Ø150	A	010813
			V.1250 eco	Ø150	A+	010814
	120	Der./Right	V.850	Ø150	A	010815
			V.1250 eco	Ø150	A+	010816
		Izq./Left	V.850	Ø150	A	010817
			V.1250 eco	Ø150	A+	010818
120 Doble rack	90	Der./Right	V.850	Ø150	A	010828
			V.1250 eco	Ø150	A+	010829
	120	Izq./Left	V.850	Ø150	A	010830
			V.1250 eco	Ø150	A+	010831
		Der./Right	V.850	Ø150	A	010832
			V.1250 eco	Ø150	A+	010833
Izq./Left	V.850	Ø150	A	010834		
	V.1250 eco	Ø150	A+	010835		

Inox esmaltado con color de la carta RAL.. Colección especial en color negro
Enamel Stainless Steel from RAL color Chart. Special collection in black color
Medidas especiales bajo estudio
Special sizes on request.

Kits de recirculación / Activated carbon filters kit:

Front. (cm).	Tipo	Ref
90	FCRL-AE	1202684
120	FCRL-AE	1202685

Opcionales* / Options*

AirLink

Modelo compatible. No se equipa de serie. Imprescindible solicitar en pedido.
Compatible Model. Is not included as standard. Must be ordered.

Sistema de filtrado ECO PLASMA ECO PLASMA filter system

Mando a distancia Touch. Suministrado con la campana.
Remote Control Touch supplied together with the hood.

Suplemento pintura Negro satinado (Ref. 010823)
Satin Black paint supplement (Ref. 010823)

Enchufes y conectores USB. Bajo presupuesto.
Plugs and USB connectors. On request.

Soporte falso techo regulable
Adjustable false ceiling support

(*) Los opcionales se suministrarán junto con la campana. Indicar claramente "OPCIONAL" en el pedido e introducir los datos de forma clara.

(*) The optionals will be supplied together with the cooker hood. Indicate clearly 'OPTIONAL' in the order and enter the data clearly.



Negro satinado
Black satin



Mando a distancia
Remote Touch Control
Ref. 620062200478



I-894 Modular

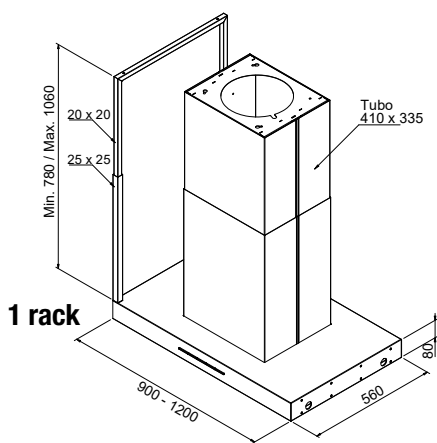

Campana / Cooker hood

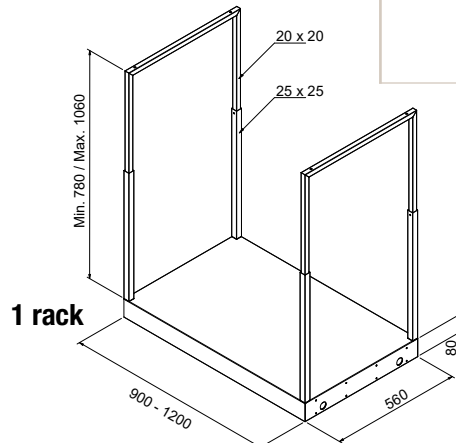

Módulos decorativos / Decorative module

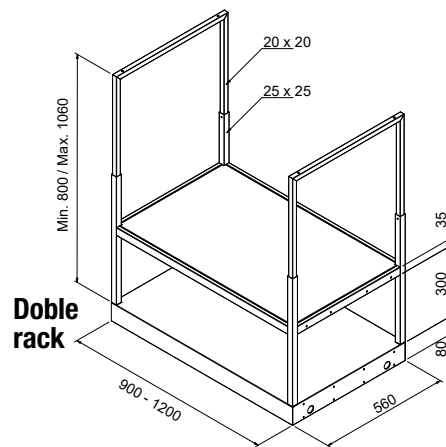
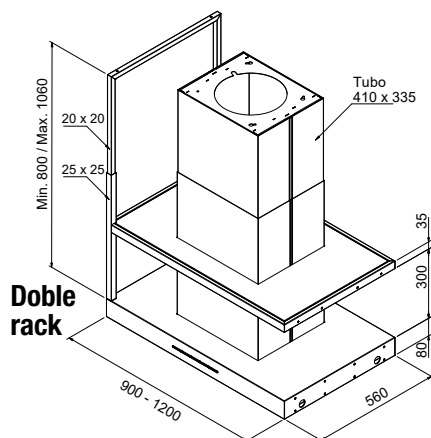
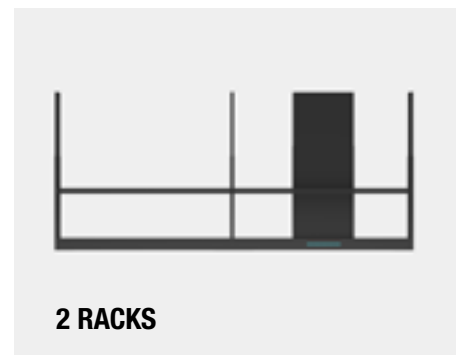
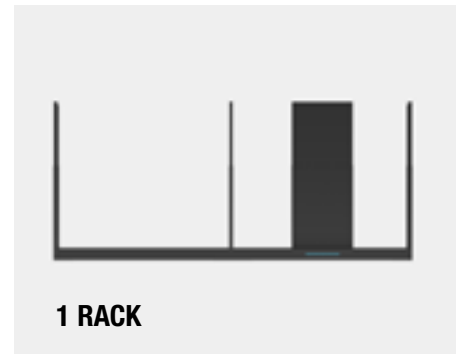

Medidas en / Dimensions in mm

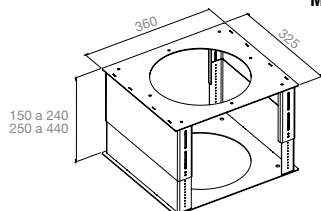

Soporte falso techo regulable
Adjustable false ceiling support

De 150 a 240 mm. Ref. 10520

De 250 a 440 mm. Ref. 10521



ZONA FILTRANTE TOTAL BLACK
TOTAL BLACK FILTER ZONE



I-897

Inox esmaltado epoxi negro o RAL. Segundo rack de cristal
Black epoxy enamel stainless steel or RAL. Second rack in glass

Opcionales* / Options*

--	--	--	--

Inox esmaltado con color de la carta RAL. Colección especial en color negro
Enamel Stainless Steel from RAL color Chart. Special collection in black color

Medidas especiales bajo estudio
Special sizes on request.

S.E.C. System® Interior / Interior

Motor	Ø tubo
V.1250 <i>eco</i>	Ø150

Intermedio exterior / Duct-in-line motor

V.1550 <i>eco</i>	Ø150
V.2450 <i>eco</i>	Ø200
V.3000 <i>eco</i>	Ø200

De tejado / Remote motor -Roof Outdoor

V.2350 <i>eco</i>	Ø200
V.3300 <i>eco</i>	Ø200

Opcionales* / Options*

AirLink

Modelo compatible. No se equipa de serie. Imprescindible solicitar en pedido.
Compatible Model. Is not included as standard. Must be ordered.

Sistema de filtrado ECO PLASMA ECO PLASMA filter system

Mando a distancia Touch. Suministrado con la campana.
Remote Control Touch supplied together with the hood.

Kits de recirculación. Bajo presupuesto.
Activated carbon filters kit. On request.

Enchufes y conectores USB. Bajo presupuesto.
Plugs and USB connectors. On request.

Soporte falso techo regulable
Adjustable false ceiling support

Filtros en INOX van de serie. Los filtros en negro son opcionales.
INOX filters are standard. Black filters are optional.

(*) Los opcionales se suministrarán junto con la campana. Indicar claramente "OPCIONAL" en el pedido e introducir los datos de forma clara.

(*) The optionals will be supplied together with the cooker hood. Indicate clearly 'OPTIONAL' in the order and enter the data clearly.



Model. 180 cm

I-897

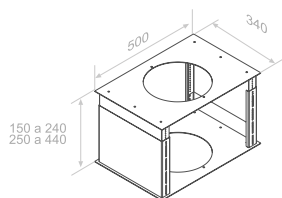

Soporte falso techo regulable
Adjustable false ceiling support

De 150 a 240 mm. **Ref. 006760**

De 250 a 440 mm. **Ref. 006761**

Negro mate RAL 9005
Black mat RAL 9005

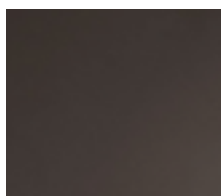

Negro satinado
Black satin



Notas / Notes

AirClean

Sistema automático de funcionamiento del motor 10 min. cada hora durante 5 horas.
Automatic working motor system for 10 minutes every hour during 5 hours.

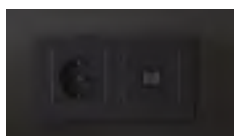

Mando a distancia
Remote Touch Control
Ref. 620062200478

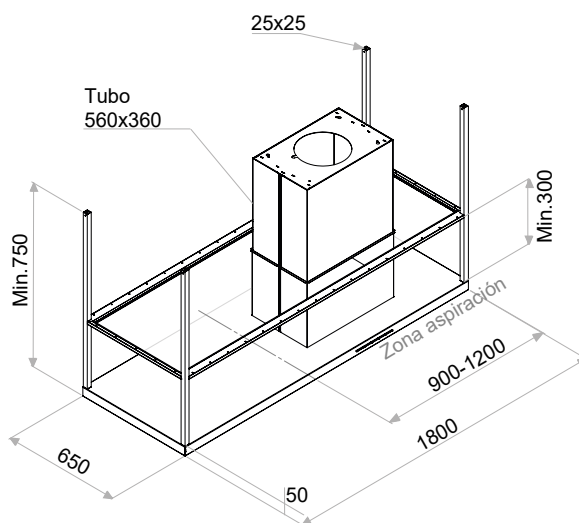

Medidas en / Dimensions in mm
Tubos especiales a medida / Special custom-made chimneys





I-898

Inox - Esmaltado epoxi negro o RAL
Black epoxy enamel - Stainless steel or RAL



I-898

Inox - Esmaltado epoxi negro o RAL
Black epoxy enamel - Stainless steel or RAL

							Opcionales* / Options*

Inox esmaltado con color de la carta RAL. Colección especial en color negro
Enamel Stainless Steel from RAL color Chart. Special collection in black color

Medidas especiales bajo estudio
Special sizes on request.

Opción 1 o 2 racks
Option 1 or 2 racks

S.E.C. System® Interior / Interior

Motor	Ø tubo
V.1250 <i>eco</i>	Ø150
V.2200 <i>eco</i>	Ø200

Intermedio exterior / Duct-in-line motor

V.1550 <i>eco</i>	Ø150
V.2450 <i>eco</i>	Ø200
V.3000 <i>eco</i>	Ø200

De tejado / Remote motor -Roof Outdoor

V.2350 <i>eco</i>	Ø200
V.3300 <i>eco</i>	Ø200

Opcionales* / Options*

AirLink

Modelo compatible. No se equipa de serie. Imprescindible solicitar en pedido.
Compatible Model. Is not included as standard. Must be ordered.

Sistema de filtrado ECO PLASMA ECO PLASMA filter system

Mando a distancia Touch. Suministrado con la campana.
Remote Control Touch supplied together with the hood.

Kits de recirculación. Bajo presupuesto.
Activated carbon filters kit. On request.

Enchufes y conectores USB. Bajo presupuesto.
Plugs and USB connectors. On request.

Soporte falso techo regulable
Adjustable false ceiling support

Filtros en INOX van de serie. Los filtros en negro son opcionales.
INOX filters are standard. Black filters are optional.

(*) Los opcionales se suministrarán junto con la campana. Indicar claramente "OPCIONAL" en el pedido e introducir los datos de forma clara.

(*) The optionals will be supplied together with the cooker hood. Indicate clearly 'OPTIONAL' in the order and enter the data clearly.



Mando a distancia
Remote Touch Control
Ref. 620062200478

Negro mate RAL 9005
Black mat RAL 9005

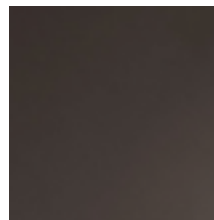

Negro satinado
Black satin





Model. 180 cm

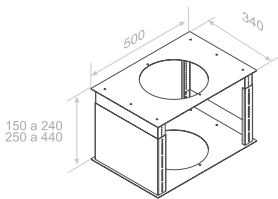

Soporte falso techo regulable
Adjustable false ceiling support

De 150 a 240 mm. Ref. 006760

De 250 a 440 mm. Ref. 006761

I-898

Fabricadas a medida. Opción 1 o 2 racks
Custom Made. Option 1 or 2 racks

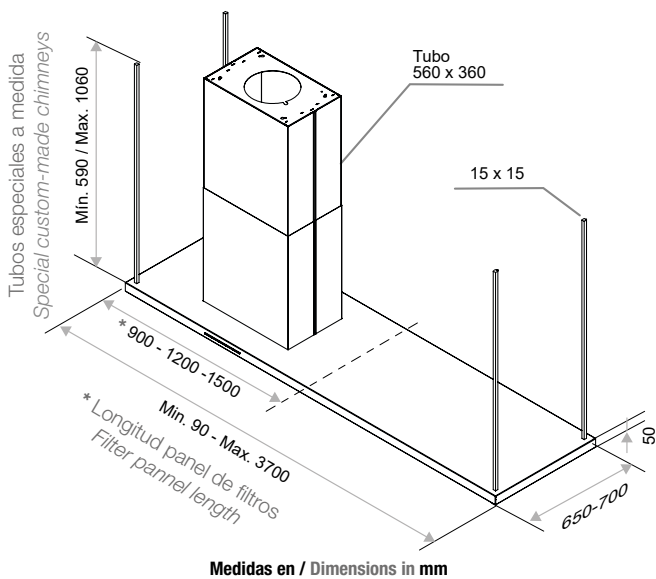

Medidas en / Dimensions in mm

Notas / Notes

AirClean

Sistema automático de funcionamiento del motor 10 min. cada hora durante 5 horas.
Automatic working motor system for 10 minutes every hour during 5 hours.

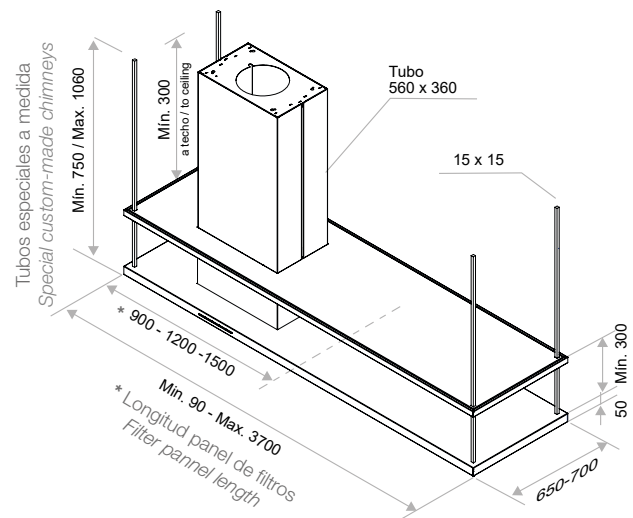

















Medidas en / Dimensions in mm



I-1300

Inox / Fabricadas a medida
Stainless Steel / Custom-made



							Opcionales* / Options*	
								

Lamas de aluminio lacadas personalizables en cualquier color de la carta RAL
Aluminium, lacquered fins, custom made in any RAL chart colour

Campana realizada a medida en cuanto a altura
Hood custom-made based on height

S.E.C. System® Motor Interior / Interior Motor

Front. (cm)	Motor	Ø tubo	Clas. Ener.	Ref.
Ø45	V.950	Ø150		

Opcionales* / Options*

AirLink

Modelo compatible. No se equipa de serie. Imprescindible solicitar en pedido.
Compatible Model. Is not included as standard. Must be ordered.

Deflector de aire para modelos de recirculación (FCLR-AE)
Air diffussor for recirculation models (FCLR-AE)

Opción de cambio de LED original a LED de 3000K. LED change to warm light
LED 3000K.

(*) Los opcionales se suministrarán junto con la campana. Indicar claramente "OPCIONAL" en el pedido e introducir los datos de forma clara.

(*) The optionals will be supplied together with the cooker hood. Indicate clearly 'OPTIONAL' in the order and enter the data clearly.



I-1300

**Fabricadas a medida.
Custom Made.**

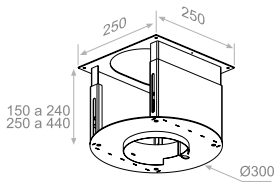

Soporte falso techo regulable
Adjustable false ceiling support

De 250 a 440 mm. Ref. 007282

Soporte falso techo
regulación de 150 a 240 mm.
en rotación (incluido)

False Ceiling Support
adjustable from 150 to 240 mm.
(included)

Soporte falso techo
regulación de 250 a 440 mm.
(opcional)

False ceiling support
adjustable from 250
to 440 mm (optional)

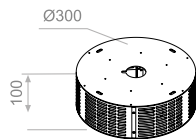

Deflector de aire para modelos
de reciclaje (FCLR-AE)
Air diffuser for recirculation
models (FCLR-AE)



Mando a distancia
Remote Touch Control
Ref. 620062200478



Alturas especiales bajo pedido. Máx. 1450 mm
Special heights on request. Max. 1450 mm

El Ø varía en función de la altura
The hood diameter varies
according to its height

Medidas en / Dimensions in mm



SKYLOOP CERAMIC

Inox - Ceramic
Stainless Steel - Ceramic

					Opcionales* Options*

AirLink

S.E.C. System® Interior / Interior

	Front. (cm)	Motor	Ø tubo	Ref.
Blanc / White	Ø69	V.1130 eco	Ø150	009722
Negro satinado / Satin black	Ø69	V.1130 eco	Ø150	009948
Oro / Gold	Ø69	V.1130 eco	Ø150	009725
Plata / Silver	Ø69	V.1130 eco	Ø150	009724
Cobre / Copper	Ø69	V.1130 eco	Ø150	009723

Opcionales* / Options*

AirLink

Modelo compatible. No se equipa de serie. Imprescindible solicitar en pedido.
Compatible Model. Is not included as standard. Must be ordered.

(*) Los opcionales se suministrarán junto con la campana. Indicar claramente "OPCIONAL" en el pedido e introducir los datos de forma clara.

(*) The optionals will be supplied together with the cooker hood. Indicate clearly 'OPTIONAL' in the order and enter the data clearly.



SKYLOOP CERAMIC

Kit cables / kit cables

L: 2500 mm 500050400114

L: 4000 mm 500050400115

Notas / Notes

Altura estándar del cable 1 metro. Alturas superiores solicitar en pedido
Cable standard height of 1 metre. Heights exceeding this size on request

Cuerpo cerámico. Base Filtrante inferior en acero inoxidable
Ceramic body. Stainless steel lower filtration base.

Iluminación circular LED 20W
Circular lighting LED 20W

Iluminación LED sólo disponible en 4000K
Lighting available only in LED 4000k

Solo disponible en sistema de filtros de carbón activado (recirculación).
Available only in activated carbon filter system (recirculation).

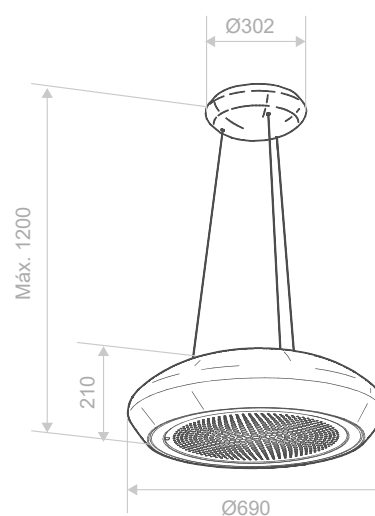

Medidas en / Dimensions in mm



A modern kitchen interior featuring light wood cabinetry, a marble countertop, and a bar area with two black stools. The kitchen includes built-in appliances like a microwave and a wine cooler. A large window offers a view of a mountain landscape. Track lighting is installed on the ceiling, and a long, dark pendant light hangs over the bar. A black text box in the upper right corner contains the text 'Pando INTEGRAL COOKING'.

Pando
INTEGRAL
COOKING

Hornos & Microondas

Cada horno de **Pando** es un ejemplo de atención al más mínimo detalle. Su objetivo es hacer que la cocina esté al alcance de todos, proporcionando una experiencia cómoda y sencilla, pero llena de posibilidades. Así, **Pando Integral Cooking** se convierte en una realidad que satisface las necesidades y expectativas de las personas.



Ovens & Microwaves

Each **Pando** oven is an example of attention to the smallest detail. Its goal is to make cooking accessible to everyone, providing a comfortable and simple experience, yet full of possibilities. In this way, **Pando Integral Cooking** becomes a reality that meets the needs and expectations of people.



Hornos
& Microondas

Ovens
& Microwaves

Todo lo que necesitas para sacar el máximo partido a tus creaciones culinarias.

Everything you need to make the most of your culinary creations.

Gama TOP



60 cm

PHB-861

HORNO MULTIFUNCIÓN
MULTIFUNCTION OVEN
60 cm - 72 L - TOUCH
p. 180

PHP-864

HORNO MULTIFUNCIÓN PIROLÍTICO
MULTIFUNCTION OVEN PYROLYSIS
60 cm - 72 L - TOUCH
p. 181

PHTV-862

HORNO MULTIFUNCIÓN + APORTACIÓN VAPOR
MULTIFUNCTION OVEN + STEAM INPUT FUNCTIONS
60 cm - 72 L - TOUCH
p. 182

45 cm

PHB-841

HORNO MULTIFUNCIÓN
MULTIFUNCTION OVEN
45 cm - 50 L - TOUCH
p. 183

PHM-850

MICROONDAS GRILL
MICROWAVE GRILL
38 cm - 34 L - TOUCH
p. 184

PHM-851

MICROONDAS + GRILL
MICROWAVE + GRILL
38 CM - 25 L - TOUCH
p. 185

38 cm





Gama PREMIUM

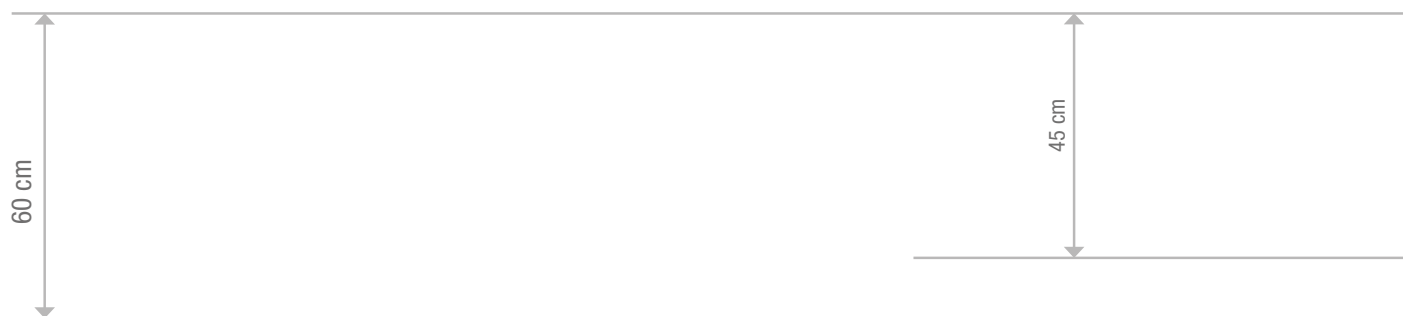

PHB-961
HORNO MULTIFUNCIÓN
 MULTIFUNCTION OVEN
60 cm - 70L
 p. 194

PHP-962
HORNO MULTIFUNCIÓN PIROLÍTICO
 MULTIFUNCTION OVEN PYROLYSIS
60 cm - 70L
 p. 196

PHT-963
HORNO MULTIFUNCIÓN
 MULTIFUNCTION OVEN
60 cm - 70L - TFT - Pando Chef
 p. 198

PHT-941
HORNO MULTIFUNCIÓN
 MULTIFUNCTION OVEN
45 cm - 44L - TFT - Pando Chef
 p. 200



PHTV-942
HORNO MULTIFUNCIÓN +
HORNO VAPOR COMPLETO
 MULTIFUNCTION OVEN +
 FULL STEAM OVEN
45 cm - 44L - TFT - Pando Chef
 p. 202

PHC-943
HORNO MULTIFUNCIÓN +
HORNO MICROONDAS "COMBI"
 MULTIFUNCTION OVEN +
 MICROWAVE OVEN "COMBI"
45 cm - 44L COMBI/MICRO
 p. 206

PHM-950 / PHM-950R
MICROONDAS + GRILL
 MICROWAVE + Grill
39 cm - 22L MICROONDAS
 p. 210

PCP-9600
CALIENTAPLATOS
 PLATE WARMER
 p. 208

Hornos &Microondas

Ovens &Microwaves

Todas las prestaciones que necesitas,
con un uso sencillo e intuitivo.

All the features you need,
with a simple and intuitive use.



**FUNCIONES
HORNO TRADICIONALES**
PROGRAMS
MULTIFUNCTIONAL OVENS



**FUNCIONES
HORNO VAPOR**
PROGRAMS
STEAM OVEN



**PRESTACIONES
DESTACABLES**
SPECIFIC
FEATURES

Gama TOP



Conexión
Connection



Convencional
Conventional



Solera
Base



Grill
Grill



MaxiGrill
MaxiGrill



MaxiGrill+turbina
MaxiGrill+fan



Convección
Convection



Convencional + turbina
Conventional + Fan



Pizza
Pizza



Eco
Eco



Descongelación
Defrosting



Fermentar masas
Ferment doughs



Pre calentamiento
rápido
Rapid preheating



Autolimpieza pirolítica
Pyrolytic self-cleaning



Microondas
Microwave



Microondas Grill
Grill Microwave



Descongelación
por peso
Defrosting by weight



Descongelación
por tiempo
Defrosting by time



Menú automático
Automatic menu



Desbloqueo
de seguridad
Unlock of security



Pando Chef
Pando Chef



Funciones aporte
de Vapor
Steam input functions



Limpieza
Cleaning



Vapor
Steam



Depósito de
agua
Water tank



Soft Close
Soft Close



Apertura puerta abatible
Downward opening door



Sonda térmica
Thermal probe



Plato giratorio
Spinning plate





Gama PREMIUM



Conexión
Connection



Convencional
Conventional



Solera
Base



Grill + solera
Grill with base



Grill
Grill



Grill+turbina
Grill+turbo



MaxiGrill
MaxiGrill



MaxiGrill+turbina
MaxiGrill+turbo



Turbo
Turbo



Turbo+solera
Turbo+base



Convencional con turbina
Conventional with turbo



Descongelación
Defrosting



Limpieza
Cleaning



Precalentamiento rápido
Fast Pre-heating



Pirólisis
Pyrolysis



Microondas grill
Microwave with grill



Microondas
Microwave



Microondas aire caliente
Microwave hot air



Fermentar masas
Ferment dough



Regeneración y esterilización
Regeneration and sterilisation



Eco
Eco



Pando Chef
Pando Chef



A fuego lento
At low heat



Desbloqueo de seguridad
Security Unlock



Vapor
Steam



Convencional
Conventional



Grill
Grill



Grill con turbina
Grill with turbo



Turbo
Turbo



Regeneración manual
Manual regeneration



Descalcificación
Decalling function



Cocción al vacío
Vacuum cooking



Dureza del agua
Hardness of water



Con puerta Soft Close
Door with Soft Close



Apertura Push-to-open
Push-to-open



Sonda térmica
Thermal probe



Grill abatible
Folding grill



Frontal abatible
Folding front



Sin plato giratorio (base cerámica)
No spinning plate (ceramic base)



Puerta fría
Cold door

Gama TOP

Hornos & Microondas

Pando incorpora la nueva e innovadora colección de hornos de gama TOP

La gama TOP ofrece al usuario una diversidad de opciones y combinaciones para la cocina, que revolucionará, a todos los niveles, los proyectos de interiorismo, gracias a sus altas prestaciones y su estética cuidada.

Esta nueva colección de hornos está compuesta por tres hornos de 60 cm con capacidad para 72 litros, un horno de 45 cm con capacidad para 50 litros y dos microondas grill, uno de 34 litros y el otro de 25 litros de capacidad.

Ovens & Microwaves

Pando incorporates the new and innovative collection of TOP range ovens

The TOP range offers the user a diversity of options and combinations for the kitchen, which will revolutionise interior design projects at all levels, thanks to its high performance and aesthetics.

This new best-in-class collection of ovens is made up of three 60cm ovens with a 72-liter capacity, a 45cm oven with a 50-liter capacity and two microwave grills, one with a 34-liter capacity and the other with a 25-liter capacity.





PHB-861

Horno Multifunción Multifunction Oven



Gama
TOP

60 cm
Altura
Height

72L
Capacidad
Capacity

11
Funciones de cocción
Cooking programs

2
Guías telescópicas
Telescopic guides

5
Alturas para la bandeja
Tray levels

Funciones hornos / Oven functions



A+

Características / Features

- Rango de temperatura 30° a 250°
- Triple aislamiento térmico de la puerta
- Tirador macizo anodizado en negro satinado
- Soft Close (Apertura y cierre amortiguado de la puerta)
- Potencia máxima: 2900 W
- Programa ECO para reducir el consumo energético
- Programa de Pre calentamiento rápido
- Bandeja pastelera profunda esmaltada
- Bandeja clásica para hornear
- Bandeja rejilla
- Iluminación interior LED
- Bloqueo de seguridad del panel de mandos (niños)

Airfry

- Operating temperature range 30° a 250°
- Triple glass door thermal insulation system
- Solid satin black anodized handle
- Soft Close (Smooth opening and closing of the door)
- Maximum Power: 2900 W
- ECO cooking función to reduce energy consumption
- Fast Pre-heating function
- Deep pastry tray enamelled
- Classic baking tray
- Grid tray
- Interior LED light
- Child safety-lock function of the control panel

Airfry

Prestaciones destacables / Special Features



Sistema de limpieza
Steam Cleaning System de Pando
Cleaning system
Steam Cleaning System by Pando



Display Touch Control
Touch Control Display



Función disponible, Julio 2025
Function available, July 2025

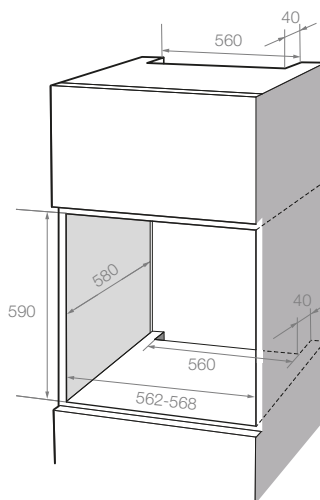

Encastre en Mueble
Built in Dimensions

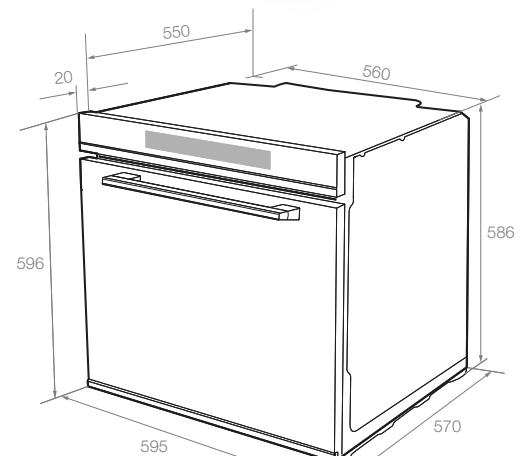

SLOWCOOK
COCINADO A BAJA TEMPERATURA
COOKING AT LOW TEMPERATURE

Medidas en / Dimensions in mm



PHP-864

Horno Multifunción PIROLÍTICO
PYROLYTIC Multifunction Oven

Gama
TOP

60 cm

Altura
Height

72L

Capacidad
Capacity

13

Funciones de cocción
Cooking programs

2

Guías telescópicas
Telescopic guides

5

Alturas para la bandeja
Tray levels

Funciones hornos / Oven functions



A+

Prestaciones destacables / Special Features



Función de autolimpieza pirólítica
Pyrolytic self-cleaning function

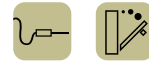

Display Touch Control
Touch Control Display

Características / Features

- Rango de temperatura 30° a 250°
- Cuádruple aislamiento térmico de la puerta
- Tirador macizo anodizado en negro satinado
- Soft Close (Apertura y cierre amortiguado de la puerta)
- Potencia máxima: 3200 W
- Programa ECO para reducir el consumo energético
- Programa de Pre calentamiento rápido
- Bandeja pastelera profunda esmaltada
- Bandeja clásica para hornear
- Bandeja rejilla
- Iluminación interior LED
- Bloqueo de seguridad del panel de mandos (niños)
- Inicio diferido

- Operating temperature range 30° a 250°
- Quaduple glass door thermal insulation system
- Solid satin black anodized handle
- Soft Close (Smooth opening and closing of the door)
- Maximum Power: 3200 W
- ECO cooking función to reduce energy consumption
- Fast Pre-heating function
- Deep pastry tray enamelled
- Classic baking tray
- Grid tray
- Interior LED light
- Child safety-lock function of the control panel
- Delayed start

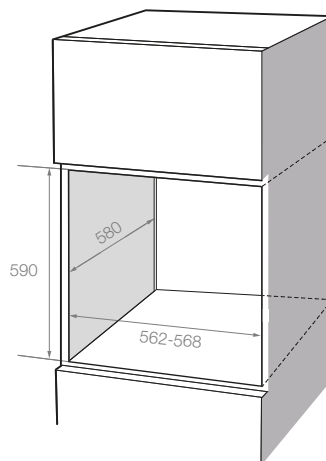

Encastre en Mueble
Built in Dimensions

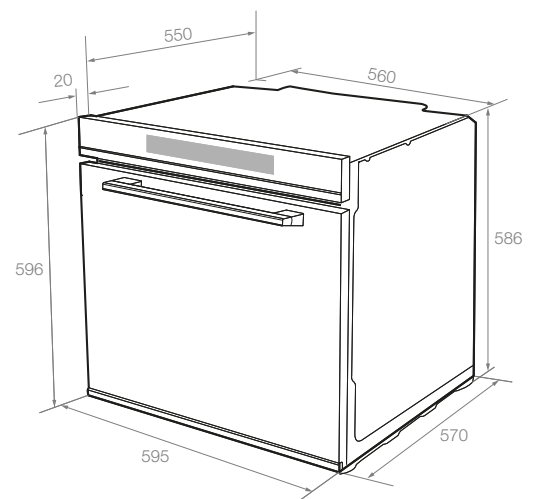

SLOWCOOK
COCINADO A BAJA TEMPERATURA
COOKING AT LOW TEMPERATURE

Medidas en / Dimensions in mm

NOTA: El mueble no debe llevar ventilación
NOTE: The cabinet should not have ventilation



PHTV-862

**Horno Multifunción
+ Aportación de Vapor
Multifunction Oven
+ Steam input functions**

Gama
TOP

60 cm

Altura
Height

72L

Capacidad
Capacity

13

Funciones de cocción
Cooking programs

2

Guías telescópicas
Telescopic guides

5

Alturas para la bandeja
Tray levels

Funciones hornos / Oven functions

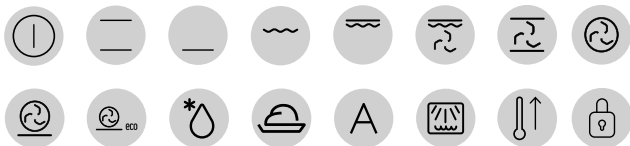

A+

Prestaciones destacables / Special Features



3 funciones aporte vapor
Steam input function

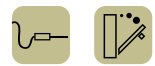

Sistema de limpieza
Steam Cleaning System de Pando
Cleaning system
Steam Cleaning System by Pando



Display Touch Control
Touch Control Display

Características / Features

- Rango de temperatura 30° a 250°
- Triple aislamiento térmico de la puerta
- Tirador macizo anodizado en negro satinado
- Soft Close (Apertura y cierre amortiguado de la puerta)
- Potencia máxima: 3150 W
- Programa ECO para reducir el consumo energético
- Programa de Pre calentamiento rápido
- Bandeja pastelera profunda esmaltada
- Bandeja clásica para hornear
- Bandeja rejilla
- Iluminación interior LED
- Bloqueo de seguridad del panel de mandos (niños)

- Operating temperature range 30° a 250°
- Triple glass door thermal insulation system
- Solid satin black anodized handle
- Soft Close (Smooth opening and closing of the door)
- Maximum Power: 3150 W
- ECO cooking función to reduce energy consumption
- Fast Pre-heating function
- Deep pastry tray enamelled
- Classic baking tray
- Grid tray
- Interior LED light
- Child safety-lock function of the control panel

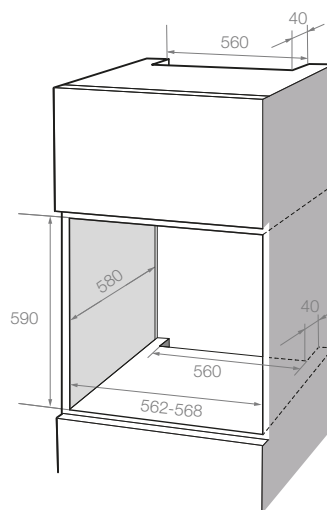

Encastre en Mueble
Built in Dimensions

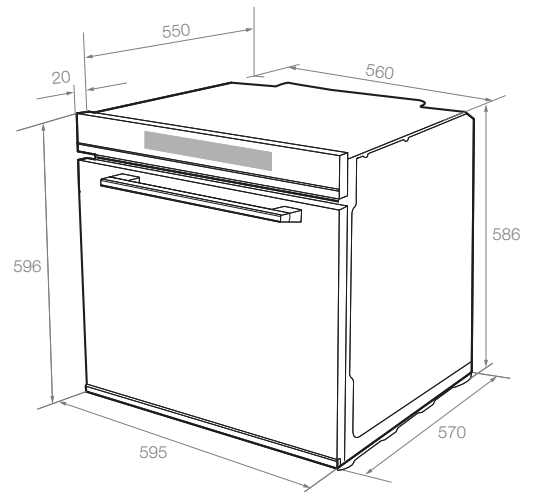

SLOWCOOK
COCINADO A BAJA TEMPERATURA
COOKING AT LOW TEMPERATURE

Medidas en / Dimensions in mm



PHB-841

Horno Multifunción Multifunction Oven

Gama
TOP

45 cm

Altura
Height

50L

Capacidad
Capacity

11

Funciones de cocción
Cooking programs

3

Alturas para la bandeja
Tray levels

Funciones hornos / Oven functions



A

Prestaciones destacables / Special Features



Sistema de limpieza
Steam Cleaning System de Pando
Cleaning system
Steam Cleaning System by Pando



Display Touch Control
Touch Control Display

SLOWCOOK

COCINADO A BAJA TEMPERATURA
COOKING AT LOW TEMPERATURE

Características / Features

- Rango de temperatura 30° a 250°
- Doble aislamiento térmico de la puerta
- Tirador macizo anodizado en negro satinado
- Potencia máxima: 3000 W
- Programa ECO para reducir el consumo energético
- Programa de Pre calentamiento rápido
- Bandeja clásica para hornear
- Bandeja rejilla
- Iluminación interior LED
- Bloqueo de seguridad del panel de mandos (niños)

- Operating temperature range 30° a 250°
- Double glass door thermal insulation system
- Solid satin black anodized handle
- Maximum Power: 3000 W
- ECO cooking función to reduce energy consumption
- Fast Pre-heating function
- Classic baking tray
- Grid tray
- Interior LED light
- Child safety-lock function of the control panel

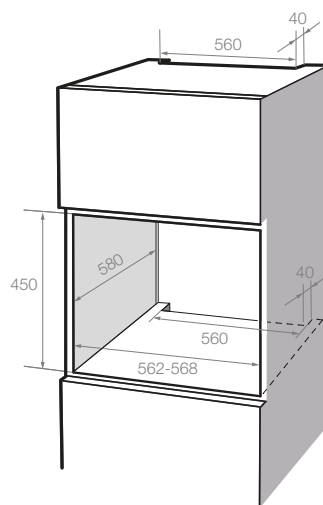

Encastre en Mueble
Built in Dimensions

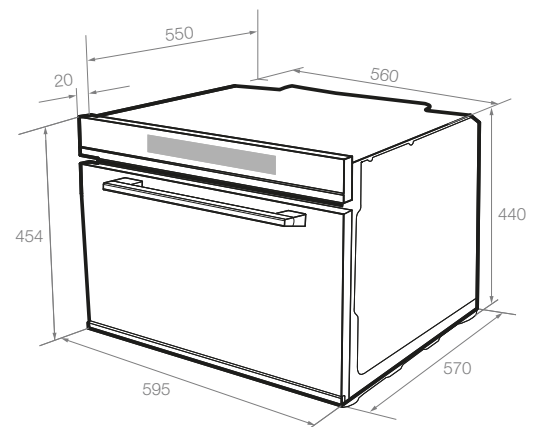

Medidas en / Dimensions in mm



PHM-850

Microondas + Grill
Microwave + Grill

Gama
TOP

38 cm

Altura
Height

34L

Capacidad
Capacity

8

Programas automáticos
Automatic programs

5

Niveles de potencia
Power levels

1

Grill de 1100W
Grill 1100W

Funciones hornos / Oven functions



Prestaciones destacables / Special Features



Características / Features

Plato giratorio Ø 34,5 cm
Apertura puerta abatible
Tirador macizo anodizado en negro satinado
5 niveles de potencia, de 90W a 900W (+Grill 1.450 W)
8 programas de funcionamiento automático
Función + 30 segundos
Display Touch Control
Función Descongelar
Función Cocinado rápido
Interior en acero inoxidable
Bloqueo de seguridad para niños en el panel de mandos
Rotary plate Ø 34,5 cm
Downward opening door
Solid satin black anodized handle
5 Power levels, from 90W a 900W (+Grill 1450W)
8 Automatic menus
Function + 30 seconds
Touch Control Display
Defrost function
Express Cooking function
Interior in stainless steel
Child safety-lock function of the Control panel

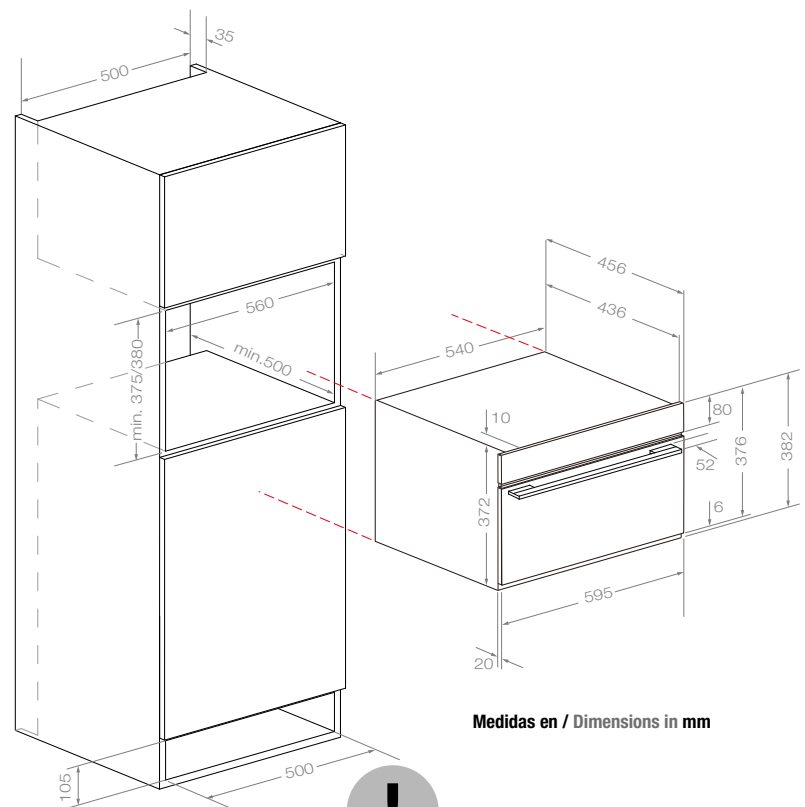

Medidas en / Dimensions in mm

NOTA: Instalación en columna
Built-in installation into column

Requiere una profundidad mínima del mueble de 500 mm.
Requires a depth of the cabinet of 500 mm.



Disponibilidad Julio 2025 / Available July 2025

PHM-851

Microondas + Grill Microwave + Grill



Gama
TOP

38 cm

Altura
Height

25L

Capacidad
Capacity

8

Programas automáticos
Automatic programs

5

Niveles de potencia
Power levels

1

Grill de 1000W
Grill 1000W

Funciones hornos / Oven functions



Prestaciones destacables / Special Features



Gran plato giratorio.
Ø 31,5 cm
Large turntable plate.
Ø 31,5 cm



Display Touch Control
Touch Control Display

Características / Features

- 8 programas de funcionamiento automático
- 5 niveles de potencia, de 90W a 900W
- Función descongelar
- Plato giratorio de Ø315 mm
- Potencia Grill: 1000 W
- Interior acero inoxidable
- Grill
- Bloqueo de seguridad del panel de mandos (niños)
- Señal fin de cocción
- 8 automatic operating programmes
- Power levels, from 90W a 900W
- Defrost function
- Turntable plate Ø315 mm
- Grill power: 1000 W
- Stainless steel interior
- Grill
- Child safety-lock function of the Control panel
- Cooking finish signal

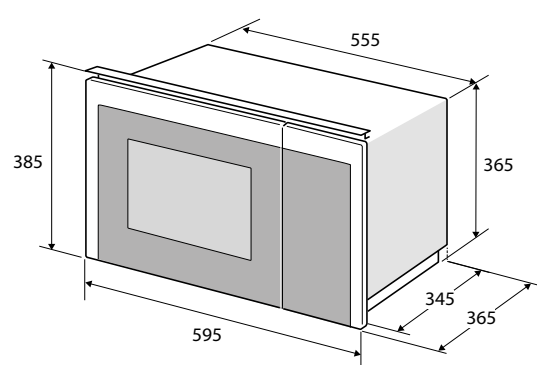
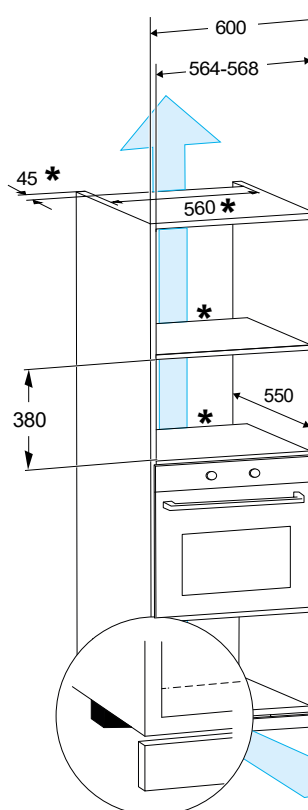

Medidas en / Dimensions in mm



Requiere una profundidad mínima del mueble de 500 mm.
Requires a depth of the cabinet of 500 mm.

NOTA: Instalación en columna
Built-in installation into column

Gama PREMIUM

Hornos & Microondas

La tecnología más vanguardista

La gama de hornos Premium de **Pando** cuenta con el diseño más elegante y la tecnología más vanguardista para su cocina.

Cada modelo de hornos ofrece a los usuarios la máxima comodidad y el más exquisito diseño con la garantía de la calidad Pando

La gama Premium ofrece una variedad de modelos especiales para cada tipo de cocina y uso del mismo, como tres hornos de 60cm con capacidad para 70 litros, tres hornos de 45cm con capacidad para 44 litros, un microondas de 22 litros y un calentaplatos.

Ovens & Microwaves

Late technology

The **Pando** Premium oven range features the most elegant design and state-of-the-art technology for your kitchen.

Pando ovens offer users maximum convenience and the most exquisite design combined with the highest Pando product quality.

The Premium oven range offers a variety of special models for every type of kitchen and cooking use, such as three 60cm ovens with a capacity of 70 litres, three 45cm ovens with a capacity of 44 litres, a 22-litre microwave oven and a plate warmer



Altas prestaciones. Máxima integración.

- 1 PANTALLA TFT CON ACCESO A RECETAS PREPROGRAMADAS. USO FÁCIL E INTUITIVO.**
Tamaño de 4". Muy visual e intuitiva. De fácil consulta.
- 2 TIRADOR NEGRO CON DETALLE INOX. POSIBILIDAD DE PERSONALIZACIÓN**
Elegante y robusto. Posibilidad de personalizarlo siguiendo la estética del resto del mobiliario de la cocina.
- 3 DOBLE SISTEMA SOFT-CLOSE DE APERTURA Y CIERRE**
Suaviza la apertura y cierre de la puerta evitando posibles portazos. Además, según el modelo, la puerta incorpora hasta cuatro cristales para un óptimo aislamiento térmico.
- 4 APERTURA AUTOMÁTICA PARA ACCESO AL DEPÓSITO DE AGUA**
Panel de mandos abatible que le permite acceder al depósito de agua de 800 ml. (en mod. PHTV-942).

Toda la tecnología. Calidad. Resistencia. Resultados.

- 1 GRILL Y MAXIGRILL ABATIBLE**
Perfecto para el gratinado más exquisito o para la cocción de las carnes más jugosas. Al ser abatible le facilita la limpieza general del interior.
- 2 CAVIDAD INTERIOR DE GRAN CAPACIDAD Y RESISTENCIA**
Interior de gran capacidad y máxima calidad gracias al esmalte SCS by Pando. Hasta 70 L. de capacidad y 5 alturas de cocinado. Posibilidad de guías extraíbles que le facilitará el trabajo, según modelo.
- 3 BANDEJAS PASTELERA Y PROFUNDA CON ESMALTE SCS BY PANDO Y Sonda TÉRMICA**
Doble bandeja de horneado para diferentes tipos de cocinado según su tamaño. Incorporación de Sonda térmica, según modelo.
- 4 DOBLE SISTEMA DE LIMPIEZA: VAPOR SCS (STEAM CLEAN SYSTEM BY PANDO) Y PIRÓLISIS 3 CICLOS**
SCS (Steam Cleaning System) tecnología que permite, mediante el vapor de agua, desincrustar la suciedad y la grasa. Pirólisis con 3 ciclos, desintegra los restos de suciedad y grasa convirtiéndolos en partículas sólidas para facilitar la limpieza.
- 5 GUÍAS TELESCÓPICAS DE EXTRACCIÓN TOTAL**
Facilita el acceso y la manipulación de los alimentos

Best-in-class performance Maximum integration.

- 4" TFT SCREEN WITH DIRECT ACCESS TO PRE-PROGRAMMED RECIPES**
Offers multiple cooking solutions by our Pando Chef. Very simple, intuitive usage and a lot of support for the unexperienced user.
- ELEGANT BLACK ALUMINIUM HANDLE WITH A FINE DETAIL IN STAINLESS STEEL**
Solid and strong handle that can be easily customized in order to match the colour of your cabinets or the finishing of your kitchen.
- DOUBLE "SOFT-CLOSE" SYSTEM (OPENING & CLOSING)**
Allows to smoothen the opening and closing of the door to avoid negative effects and future damages of slamming doors. In addition, the door incorporates between 3 and 4 layers of glass, to ensure perfect heat isolation.
- SIMPLE PUSH-TO-OPEN DIRECT ACCESS TO THE WATER DEPOSIT**
Control Panels folds down and provides easy and direct access to an 800ml water deposit for the steam oven (PHTV-942).

Latest technology. Quality. Resistance. Results.

- FOLDABLE GRILL AND MAXI GRILL**
Includes a grill and/or maxigrill function to ensure that your favourite dish receives the perfect gratin, and steaks stay juicy inside. Being "foldable" makes easier the overall cleaning process of the oven interior.
- RESISTENT INTERIOR CAVITY WITH GREAT CAPACITY**
The latest generation of Pando ovens offer a capacity of 70 L and up to 5 levels for cooking. The black interior is finished with very heat resistant enamel SCS by Pando. Telescopic guides simplify placing and taking out the trays.
- DEEP PASTRY TRAY WITH HEAT RESISTANT SCS ENAMEL BY PANDO / THERMAL PROBE**
Double baking tray for different types of cooking according to type and quantity of the food. Pando Steam Oven even permits cooking with a thermal probe.
- TWO STATE-OF-THE-ART CLEANING SYSTEMS: SCS Steam Cleaning by Pando and 3 CYCLES OF PYROLYSIS**
SCS Steam Cleaning by Pando is a very environmental-friendly technology that permits to clean your oven by using water and steam to eliminate easily even embedded rests of food and grease. Pyrolysis is a very heat intensive process that converts grease and embedded food rests into solid particles that then can be easily removed.
- TELESCOPIC TOTAL SLIDE-OUT GUIDES**
Facilitates access and handling of food.

outside



Gama
PREMIUM

inside



Hornos & Microondas

Dos sistemas de limpieza.
Rápidos. Eficaces. Ecológicos.

Ovens & Microwaves

Two cleaning systems.
Fast. Efficient. Ecofriendly.



STEAM CLEANING SYSTEM

La tecnología Steam Cleaning System es rápida, eficaz y ecológica.
Un sistema de limpieza en cuatro sencillos pasos:

1. Con el horno en frío, vierte un vaso de agua en la base.
2. Selecciona la función Steam Cleaning System.
3. El agua se evapora y condensa en las paredes, haciendo que se desprendan la grasa y la suciedad. El horno se enfría, para que puedas pasar al cuarto paso sin peligro de quemaduras.
4. Límpialo con un paño sin necesidad de productos adicionales.

En menos de media hora tu horno quedará limpio.
Este sistema se puede utilizar después de cada uso del horno.
Sistema de limpieza muy eficiente por su bajo consumo eléctrico.

Technology Steam Cleaning System. Fast, Efficient & Ecofriendly.
Four easy steps:

1. Pour a glass of water on the bottom of the oven.
2. Select the Steam Cleaning System function.
3. The water evaporates and condenses on the walls, loosening grease and dirt.
4. When the oven cools down, wipe it out with a cloth. There is no need for any chemical cleaning products.

In less than 30 minutes your oven will again be perfectly clean.
The SCS System by Pando can be used every time you use your oven.
Very energy efficient cleaning system.

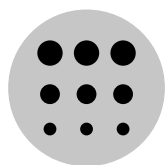

PYROLYSIS SYSTEM

SISTEMA PIROLÍTICO 3 CICLOS DE TIEMPO DIFERENCIADOS

Este innovador sistema hace que, gracias a la elevada temperatura, los restos de grasa o comida que quedan incrustados en nuestro horno después de su uso y que cuestan tanto de limpiar, se descompongan de tal manera que nos resulte muy fácil su eliminación.

PYROLYSIS CLEANING SYSTEM WITH 3 DIFFERENT CLEANING CYCLES

Using very high temperatures, this latest-generation cleaning process breaks down grease or food residues that often remain embedded in the oven walls and are often extremely difficult to remove. Once broken down by pyrolysis, they can be easily removed with a soft cloth.



STEAM CLEANING SYSTEM

Gama
PREMIUM



PYROLYSIS SYSTEM



Hornos & Microondas

Tiradores personalizados

Nuestra gama de hornos ofrece la posibilidad de personalizar sus tiradores, substituyendo el frontal del tirador por otro con el acabado que usted desee.

Ovens & Microwaves

Customized handles

Our range of ovens offers the possibility to customize its handles, replacing the standard front of the handle by a material or finishing of your choice.

Tirador personalizable
(con dimensiones interiores)
Customizable handle
(with inside dimensions)

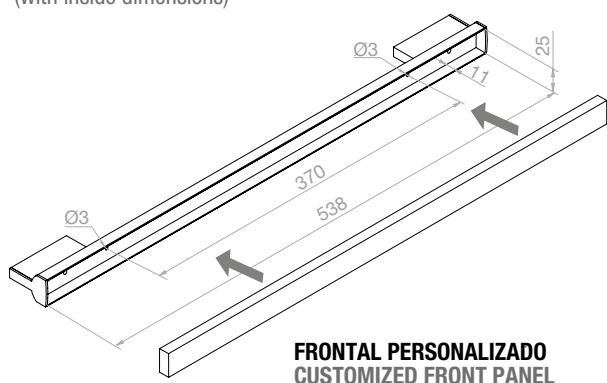

Ref.	Descripción / Description
010185	Tirador personalizable Customizable handle
010186	Tirador personalizable + Frontal Oro Customizable handle + Gold front
010187	Tirador personalizable + Frontal Cobre Customizable handle + Copper front
010192	Tirador personalizable + Frontal Inox Customizable handle + S/Steel front



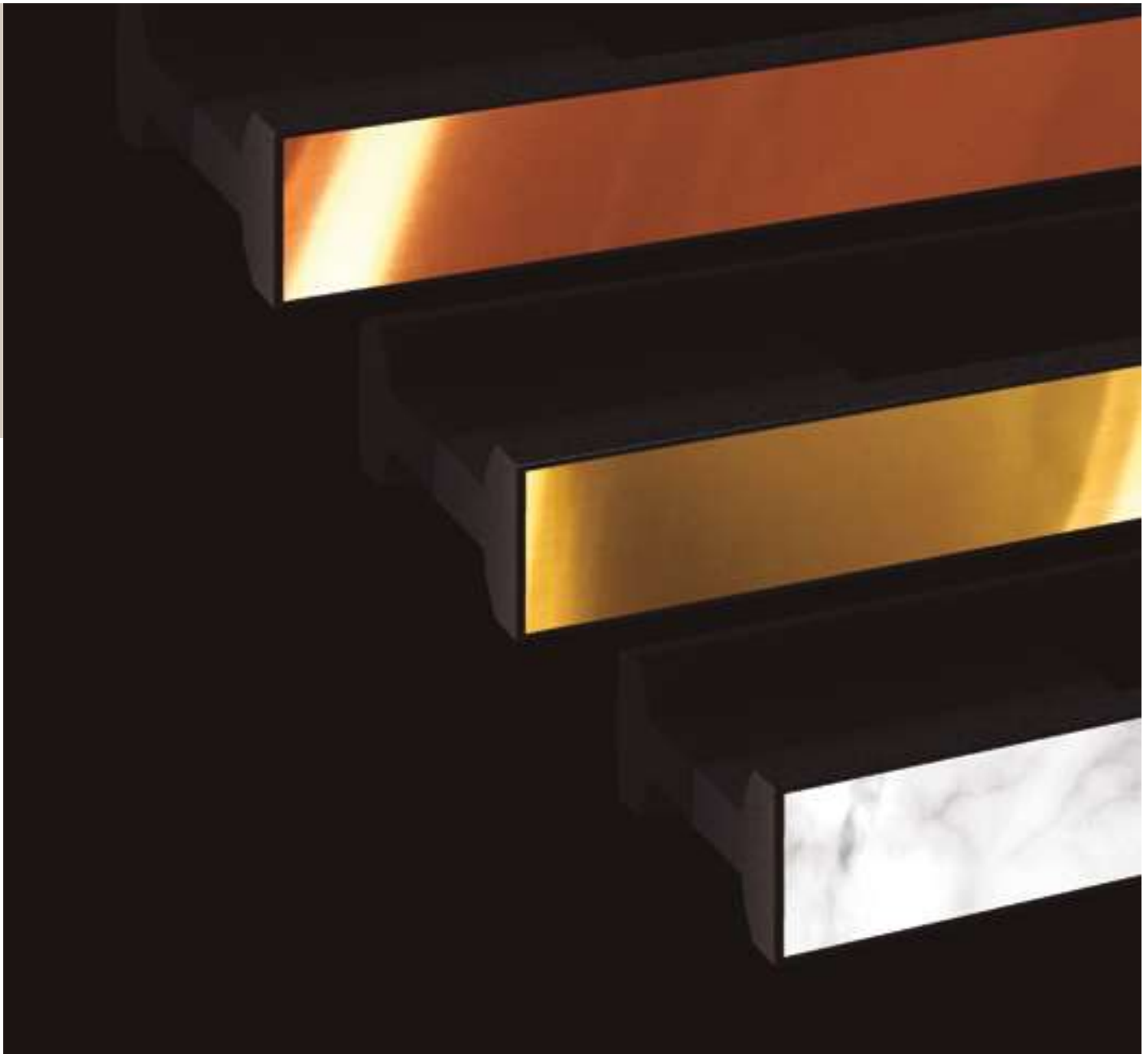



PHB-961

Horno multifunción

Multifunction Oven

60 cm

Altura
Height

70L

Capacidad
Capacity

12

Funciones
Programs

2

Guías extraíbles
Slide out guides

5

Alturas de cocinado
Cooking levels

Prestaciones destacables / Special Features



Steam Cleaning System (SCS) by Pando



A+

Características / Features

Rango de temperatura 50° a 250°	Operating temperature range 50°C to 250°C
Triple aislamiento térmico de la puerta	Triple glass door thermal insulation system
Tirador macizo anodizado en negro satinado	Solid aluminium anodized black handle
Soft Close (Apertura y cierre amortiguado de la puerta)	Soft Close (Smooth opening and closing of the door)
Propuesta automática de temperatura y tiempo	Automatic proposal of temperature and cooking time
Programador Touch Control de inicio y parada de cocción	Touch Control to choose Start and Stop of the cooking process
Función ECO	ECO program
Grill / Maxigrill, abatible	Fold-away Grill / Maxi Grill
Bandejas pastelera y profunda con esmalte SCS by Pando	Baking tray and Deep tray with SCS coating by Pando
Parrilla reforzada	Reinforced Grill
Iluminación Interior	Internal Lighting
Desconexión de seguridad en apertura de puerta	Safety switch-off function when door is opened
Bloqueo de seguridad para niños del panel de mandos	Child safety-lock function of the Control panel
Cavidad interior esmaltada by Pando	Enamel Interior by Pando
Modo Demo - Showroom	Demo mode - Showroom mode

Funciones hornos / Oven functions

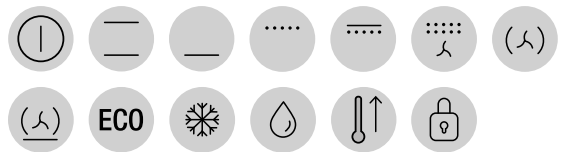

Gama
PREMIUM



PHB-961

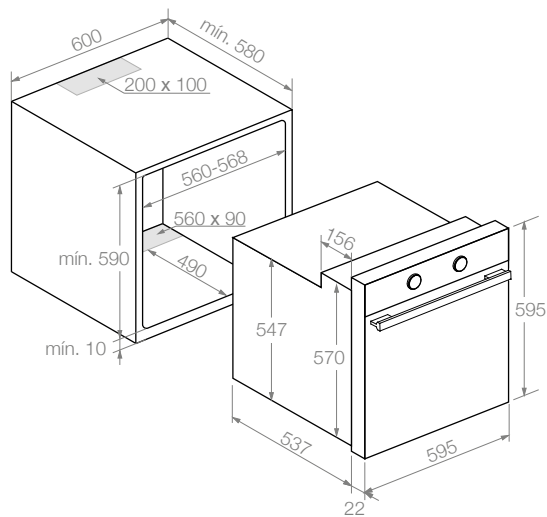
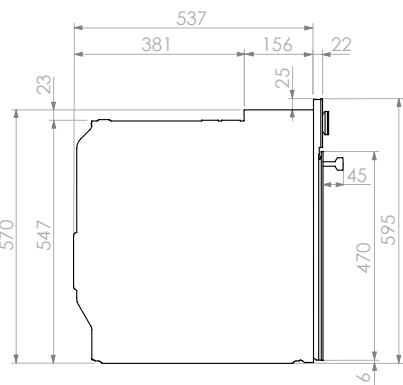

Medidas en / Dimensions in mm





PHP-962

Horno Multifunción Pirolítico Multifunction Oven Pyrolysis

60 cm

Altura
Height

70L

Capacidad
Capacity

12

Funciones
Programs

2

Guías extraíbles
Slide out guides

5

Alturas de cocinado
Cooking levels

Prestaciones destacables / Special Features



**Steam
Cleaning
System
by Pando**



**Pirólisis
Pyrolysis**



Puerta fría, excepto proceso pirólisis
Cold door, except pyrolysis process

Funciones hornos / Oven functions



A+

Características / Features

Rango de temperatura 50° a 250°	Operating temperature range 50°C to 250°C
Cuadruple aislamiento térmico de la puerta	Quadruple glass door thermal insulation system
Doble sistema de limpieza, Pirolítico y Vapor SCS by Pando	Double Cleaning System: Pyrolysis and Steam "SCS by Pando"
Pirólisis 3 ciclos - P1: 60 min. - P2: 90 min. - P3: 120 min	3 cycles of Pyrolysis - P1: 60 minutes, P2: 90 minutes, P3: 120
Tirador macizo anodizado en negro satinado	Solid aluminium anodized black handle
Soft Close (Apertura y cierre amortiguado de la puerta)	Soft Close (Smooth opening and closing of the door)
Propuesta automática de temperatura y tiempo	Automatic proposal of temperature and cooking time
Función ECO	ECO program
Grill / Maxigrill	Grill / Maxigrill
Bandejas pastelera y profunda con esmalte SCS by Pando	Baking tray and Deep tray with SCS coating by Pando
Parrilla reforzada	Reinforced Grill
Iluminación Interior	Internal Lighting
Programador Touch Control de inicio y parada de cocción	Touch Control to Start and Stop the cooking process
Desconexión de seguridad en apertura de puerta	Safety switch-off function when door is opened
Bloqueo de seguridad para niños del panel de mandos	Child safety-lock function of the Control panel
Cavidad interior esmaltada by Pando	Enamel Interior by Pando
Modo Demo - Showroom	Demo mode - Showroom mode



Gama
PREMIUM

PHP-962

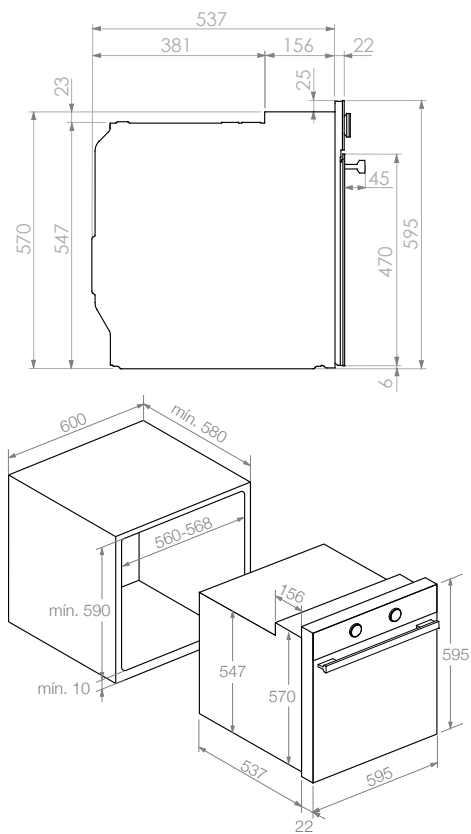

Medidas en / Dimensions in mm

NOTA: El mueble no debe llevar ventilación
NOTE: The cabinet should not have ventilation





PHT-963

Horno Multifunción Pando Chef Multifunction Oven Pando Chef

60 cm

Altura
Height

70L

Capacidad
Capacity

14

Funciones
Programs

2

Guías extraíbles
Slide out guides

5

Alturas de cocinado
Cooking levels

Prestaciones destacables / Special Features



**Steam
Cleaning
System
by Pando**



Pando Chef
Asesor personal de cocinado con
20 recetas preprogramadas
Personal Cooking Advisor
(20 pre-set recipes)



Pantalla TFT de 4"
4" TFT Screen

SLOWCOOK

COCINADO A BAJA TEMPERATURA
COOKING AT LOW TEMPERATURE

A+

Funciones hornos / Oven functions



Características / Features

Rango de temperatura 30° a 270°

Triple aislamiento térmico de la puerta

Tirador macizo anodizado en negro satinado

Soft Close (Apertura y cierre amortiguado de la puerta)

Propuesta automática de temperatura y tiempo

Sistema de limpieza por vapor SCS by Pando

Función ECO

Grill / MaxiGrill, abatible

Bandejas pastelera y profunda con esmalte SCS by Pando

Parrilla reforzada

Mandos retroiluminados

Iluminación Interior

Programador Touch Control de funciones

Desconexión de seguridad en apertura de puerta

Bloqueo de seguridad para niños del panel de mandos

Cavidad interior esmaltada by Pando

Modo Demo - Showroom

Operating temperature range 30°C to 270°C

Triple glass door thermal insulation system

Solid aluminium anodized black handle

Soft Close (Smooth opening and closing of the door)

Automatic proposal of temperature and cooking time

Steam Cleaning System "SCS by Pando"

ECO program

Fold-away Grill / MaxiGrill

Baking tray and Deep tray with SCS coating by Pando

Reinforced Grill

Backlit control knobs

Internal Lighting

Touch Control to choose cooking programs

Safety switch-off function when door is opened

Child safety-lock function of the Control panel

Enamel Interior by Pando

Demo mode - Showroom mode

Gama
PREMIUM

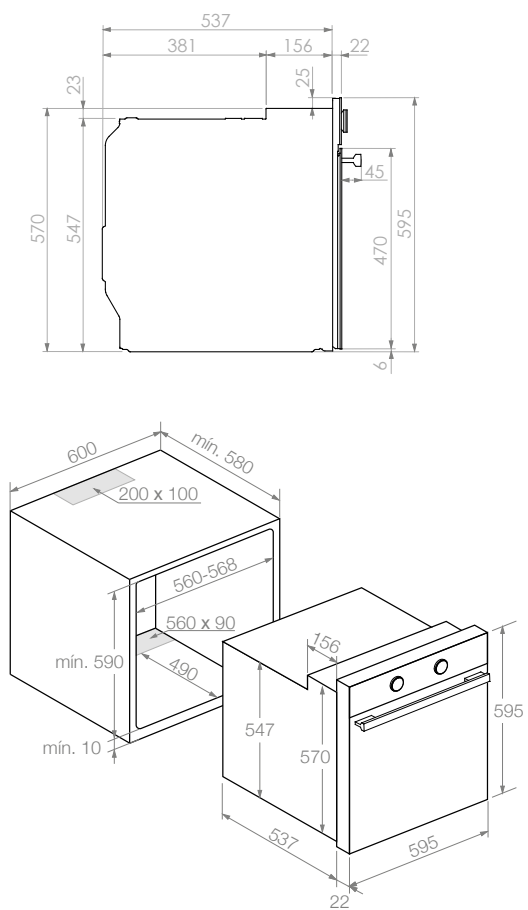

Medidas en / Dimensions in mm

PHT-963





PHT-941

Horno Multifunción Pando Chef Multifunction Oven Pando Chef

45 cm

Altura
Height

44L

Capacidad
Capacity

14

Funciones
Programs

1

Guías extraíbles
Slide out guides

3

Alturas de cocinado
Cooking levels

Prestaciones destacables / Special Features



**Steam
Cleaning
System
by Pando**



Pando Chef

Asesor personal de cocinado con
20 recetas preprogramadas
Personal Cooking Advisor
(20 pre-set recipes)



Pantalla TFT de 4"
4" TFT Screen

SLOWCOOK

COCINADO A BAJA TEMPERATURA
COOKING AT LOW TEMPERATURE

A+

Funciones hornos / Oven functions

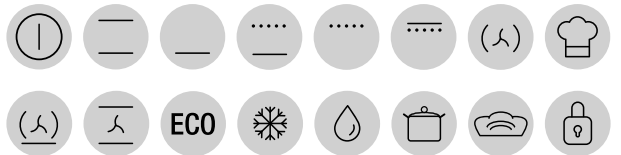

Características / Features

Rango de temperatura 30° a 270°	Operating temperature range 30°C to 270°C
Triple aislamiento térmico de la puerta	Triple glass door thermal insulation system
Tirador macizo anodizado en negro satinado	Solid aluminium anodized black handle
Soft Close (Apertura y cierre amortiguado de la puerta)	Soft Close (Smooth opening and closing of the door)
Propuesta automática de temperatura y tiempo	Touch Control to choose cooking programs
Sistema de limpieza por vapor SCS by Pando	Automatic proposal of temperature and cooking time
Función ECO	ECO programm
Grill / MaxiGrill, abatible	Fold-away Grill / MaxiGrill
Bandejas pastelera y profunda con esmalte SCS by Pando	Baking tray and Deep tray with SCS coating by Pando
Parrilla reforzada	Reinforced Grill
Mandos retroiluminados	Backlit control knobs
Iluminación Interior	Internal Lighting
Programador Touch Control de funciones	Touch Control to choose cooking programs
Desconexión de seguridad en apertura de puerta	Safety switch-off function when door is opened
Bloqueo de seguridad para niños del panel de mandos	Child safety-lock function of the Control panel
Cavidad interior esmaltada by Pando	Enamel Interior by Pando

Gama
PREMIUM



PHT-941

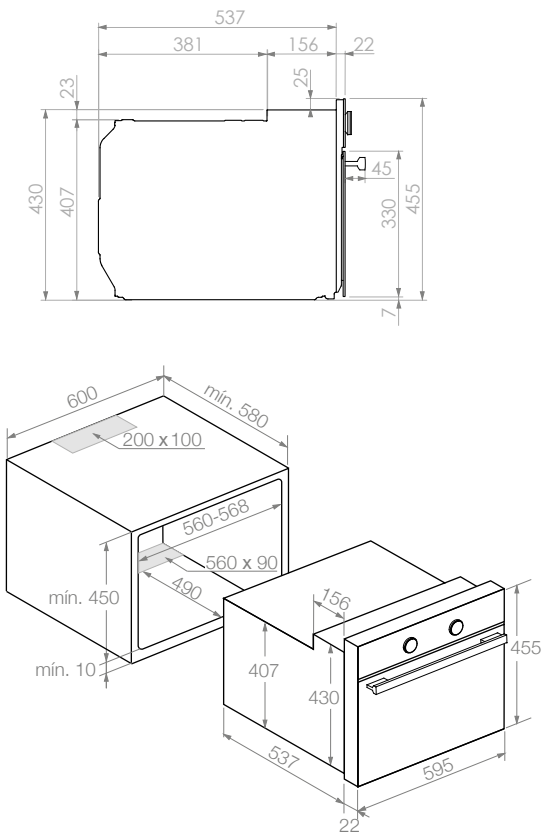

Medidas en / Dimensions in mm





vapor
steam

PHTV-942

Horno multifunción
+ Horno vapor completo

Listo para todo
lo que necesites

Multifunction Oven
+ Full steam oven

Includes everything
you can dream of

tradicional
traditional



completa
integral



Conviértase en
un auténtico **Chef**

Todas las opciones de cocinado en un mismo horno y además con "Pando Chef", su asesor personal para que todo salga perfecto.



Become
a real **Chef**

Combines all options and needs for a perfect cooking in one single oven, including "Pando Chef", your personal assistant to ensure that the outcome is always perfect.



PHTV-942

Horno Multifunción + Horno Vapor completo
Multifunction Oven + Full Steam Oven

3 en 1

45 cm

Altura
Height

44L

Capacidad
Capacity

14

Funciones
Programs

9

Funciones Vapor
Steam programs

3

Bandejas cocinado
Cooking trays

Prestaciones destacables / Special Features



Pando Chef

Asesor personal de cocinado con 20 recetas preprogramadas
 Personal Cooking Advisor
 (20 pre-set recipes)



Horno vapor
Steam oven



Pantalla TFT de 4"
4" TFT Screen

SLOWCOOK

COCINADO A BAJA TEMPERATURA
 COOKING AT LOW TEMPERATURE

A+

Funciones hornos / Oven functions



Funciones horno vapor / Steam Oven functions



Características / Features

Rango de temperatura - Multifunción 30° a 270°	Operating temperature range - Multi-function 30°C to 270°C
Rango de temperatura - Vapor 35° a 100°	Operating temperature range - Steam 35°C to 100°C
Triple aislamiento térmico de la puerta	Triple glass door thermal insulation system
Tres Bandejas de cocinado: 1 esmaltada SCS by Pando + 1 Bandeja Vapor en Inox + 1 Rejilla	Three Cooking trays: enamel SCS by Pando + 1 S/Steel Steam tray + 1 Rack
Cocción por sonda térmica	Cooking with thermal probe
Apertura automática del Panel de Mandos para acceder al depósito de agua	Automatic Panel Control opening for easy access to water tank
Mandos retroiluminados	Backlit control knobs
Tirador macizo anodizado en negro satinado	Solid aluminium anodized black handle
Soft Close (Apertura y cierre amortiguado de la puerta)	Soft Close (Smooth opening and closing of the door)
Propuesta automática de temperatura y tiempo	Automatic proposal of temperature and cooking time
Función ECO	ECO programm
Grill / MaxiGrill	Grill / MaxiGrill
Iluminación Interior	Internal Lighting
Desconexión de seguridad en apertura de puerta	Safety switch-off function when door is opened
Bloqueo de seguridad para niños del panel de mandos	Child safety-lock function of the Control panel
Cavidad interior esmaltada by Pando	Enamel Interior by Pando

Gama
PREMIUM



PHTV-942

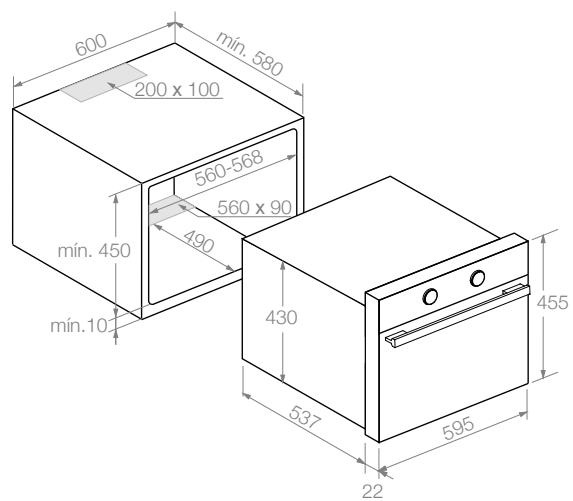
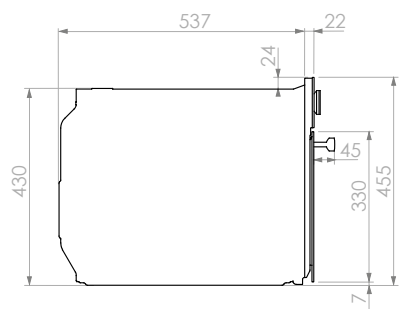

Medidas en / Dimensions in mm





PHC-943

Horno Multifunción + Horno Microondas "COMBI"
Multifunction Oven + Microwave Oven "COMBI"

45 cm

Altura
Height

44L

Capacidad
Capacity

7

Funciones
Programs

5

Niveles de potencia
Power levels

2

Bandejas cocinado
Cooking trays

Prestaciones destacables / Special Features



Combi+Micro

Horno Multifunción, Grill y Microondas, todo en uno
Combi + Micro: four multifunction, grill and microwave, all in one



Puerta fría
Cold door

A+

Funciones hornos / Oven functions

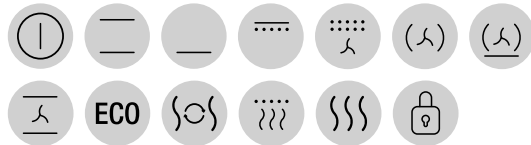

Display digital Touch Control multifunción con selector de tiempo y funciones
Multifunctional Digital Touch Control Display with timer and program selection

Características / Features

Rango de temperatura 50° a 250°	Operating temperature range 50°C to 250°C
Triple aislamiento térmico de la puerta	Triple glass door thermal insulation system
5 niveles de potencia como microondas, de 200W a 1000W	5 microwave power levels, from 200W to 1000W
Tirador macizo anodizado en negro satinado	Solid aluminium anodized black handle
Grill / MaxiGrill	Grill / MaxiGrill
Descongelación automática por tiempo y peso	Automatic defrost based on time and weight
Función + 30 segundos	Function + 30 seconds
Temporizador de 0 a 90 minutos	Timer from 0 to 90 minutes
Bandeja de cristal + Parrilla reforzada	Glass tray + Reinforced Grill
Iluminación Interior	Internal Lighting
Bloqueo de seguridad para niños del panel de mandos	Child safety-lock function of the Control panel
Cavidad interior esmaltada by Pando	Enamel Interior by Pando
Modo Demo - Showroom	Demo mode - Showroom mode

Gama
PREMIUM



PHC-943

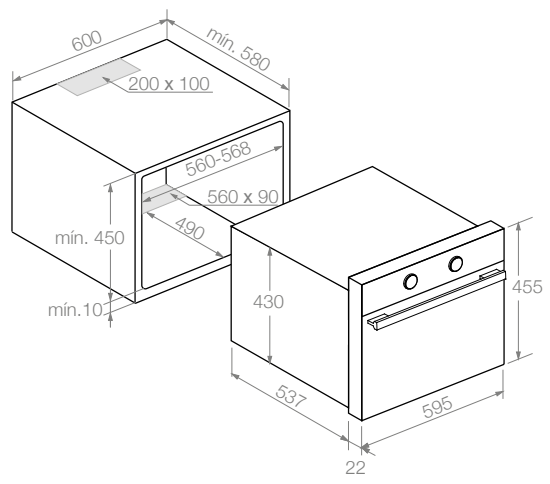
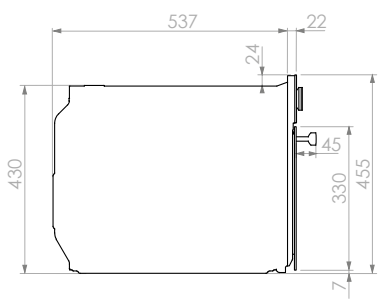

Medidas en / Dimensions in mm





PCP-9600

Calientaplatos Plate warmer

Sistema de aire caliente con termostato y ventilador que distribuye de forma óptima el calor en el cajón.

El fondo del cajón está provisto de un recubrimiento antideslizante que impide que la vajilla se mueva al abrir o cerrar el cajón.

Hot Air Fan and thermostat system for evenly heat fine distribution across the drawer.

The bottom of the drawer is provided with a non-slip coating avoiding the dish from moving when opening and closing the plate warmer.

Temperaturas / Temperatures*

Precalentar vajillas Preheating crockery	60°
Calor constante Constant heat	70°
Desgongelar Defrost	30°
Calentar Heating	80°
Cocción a baja temperatura Low temperature cooking	80°

(*)

Los valores indicados son orientativos y pueden variar según las condiciones de uso, el material de la vajilla y la cantidad de carga.

The values given are approximate and may vary according to the conditions of use, the material of the dishware and the amount of the amount of load.

Prestaciones destacables / Special Features



Características / Features

Rango de temperatura 30° a 80°	Operating temperature range 30°C to 80°C
Servicio para 6 personas	Service for 6 people
6 platos planos de 24 cm	6 x 24 cm flat plates
6 platos soperos de 10 cm	6 x 10 cm deep plates
1 fuente de 17, 19 o 32 cm	1 Baking bowl of 17Ø cm , 19Ø cm or 32Øcm
20 platos de 28cm de diámetro	20 flat plates of 28 Ø cm
80 tazas de café	80 coffee cups
40 tazas de té	40 tea cups
Base antideslizante	Non-sliping base
Apertura Push-to-open	Push-to-Open
Frontal de cristal negro	Black glass front
Touch Control	Touch control
Tiempo de 0 - 4 horas	Timer from 0 to 4 hours

Gama
PREMIUM



PCP-9600

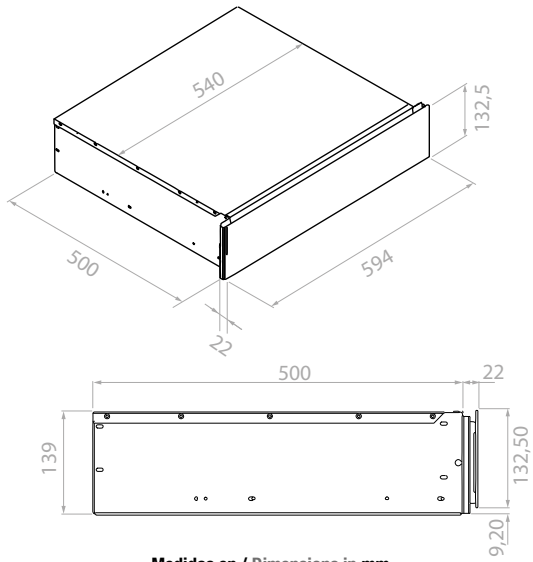

Medidas en / Dimensions in mm





PHM-950 / PHM-950R

Horno Microondas + Grill
Microwave Oven + Grill

39 cm

Altura
Height

22L

Capacidad
Capacity

7

Funciones
Programs

5

Niveles de potencia
Power levels

1

Grill 1200 W
1200 W Grill

PHM-950

Apertura izquierda
Opens to the left

PHM-950R

Apertura derecha
Opens to the right

Prestaciones destacables / Special Features



Pando Chef

Función de cocinado preprogramada para 5 tipos de alimentos
Preprogrammed cooking function for 5 types of food

Display digital
Display digital

Funciones hornos / Oven functions

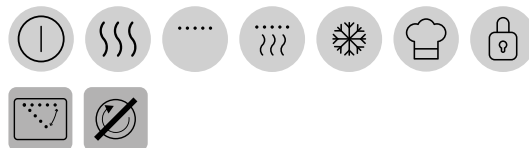

Características / Features

Microondas base cerámica	Ceramic based microwave oven
Perfil de aluminio anodizado negro	Black anodized aluminum profile
5 niveles de potencia, de 90W a 850W	5 power levels, from 90W to 850W
5 programas de descongelación automática por tiempo y peso	5 automatic defrost programs by time and weight
3 menús de acceso directo: microondas/grill/microondas+Grill	3 direct access panels: Microwave / Grill / Microwave+Grill
Temporizador de 0 a 90 minutos	Timer from 0 to 90 minutes
Función + 30 segundos	Function + 30 seconds
Interior en acero inoxidable	Interior in S/Steel
Parrilla especial grill	Special grill
Grill abatible	Fold-away Grill
Apertura electrónica de puerta	Electronic Door opening
Bloqueo de seguridad para niños en el panel de mandos	Child safety-lock function of the control panel
Modo Demo - Showroom	Demo mode - Showroom mode

Gama
PREMIUM



PHM-950 / PHM-950R

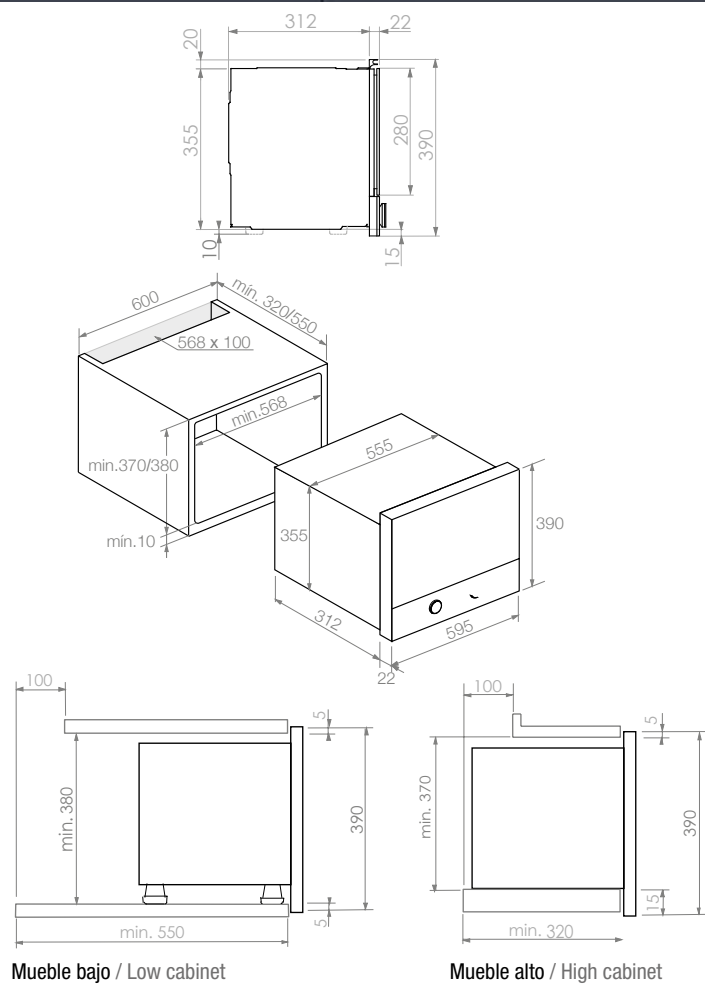

Mueble bajo / Low cabinet

Mueble alto / High cabinet

Medidas en / Dimensions in mm





PHM-950

Gama PREMIUM

Microondas
Microwave Oven

Fácil instalación tanto en mueble alto como en columna

Easy built-in installation into both: cabinets and columns

Nuestro Microondas PHM-950 está preparado para su instalación en mueble alto sin que tenga que modificar ni alterar el mueble.

Our new microwave PHM-950 is especially designed to be installed fully Built-in into tall units, without having to adapt the cabinet.

PHM-950

Accesorio cristal negro
Black glass accessory

Instalación perfecta en batería

Perfect installation in-line

No limite sus opciones de diseño por la diferencia de alturas entre los elementos de cocción.

Cristal negro 6 cm que permite equilibrar alturas con un horno de 45 y el microondas cuando se instalan en batería.

Do not limit your design options by the difference in heights between the cooking elements.

Black glass front piece that allows you to balance heights between a 45 cm oven and microwave when installed horizontally.



Ref.	Medias / Size
010188	595 x 60 x 4mm

Consultar otras medidas / Other sizes on request

Horno **Pando**
Oven



45,5 cm



39 cm

Microondas **Pando**
Microwave

6 cm

Accesorio **Pando**
Accessory

Horno **Pando**
Oven



45,5 cm



6 cm

Accesorio **Pando**
Accessory

39 cm

Microondas **Pando**
Microwave

Pando TOWER

La columna **totalmente Integrada** perfecta para cocinar

Un conjunto de productos **Pando**, perfectamente coordinados, diseñados para brindarte todas las comodidades de una cocina moderna y completamente equipada. Esta combinación ha sido pensada para ofrecerte todo lo que necesitas, permitiéndote disfrutar de tus platos y vinos favoritos siempre en su punto exacto.

A fully built-in, **completely integrated** column solution.

A perfectly coordinated set of Pando kitchen appliances designed to give you all the comforts of a modern, fully equipped kitchen.

This combination has been thought to offer you everything you need, allowing you to enjoy your favorite dishes and wines always at their exact point.

VISTA FRONTAL DEL MUEBLE
FRONT VIEW

Mueble grosor de 16 o de 19 mm.
Cabinet thickness 16 or 19 mm.

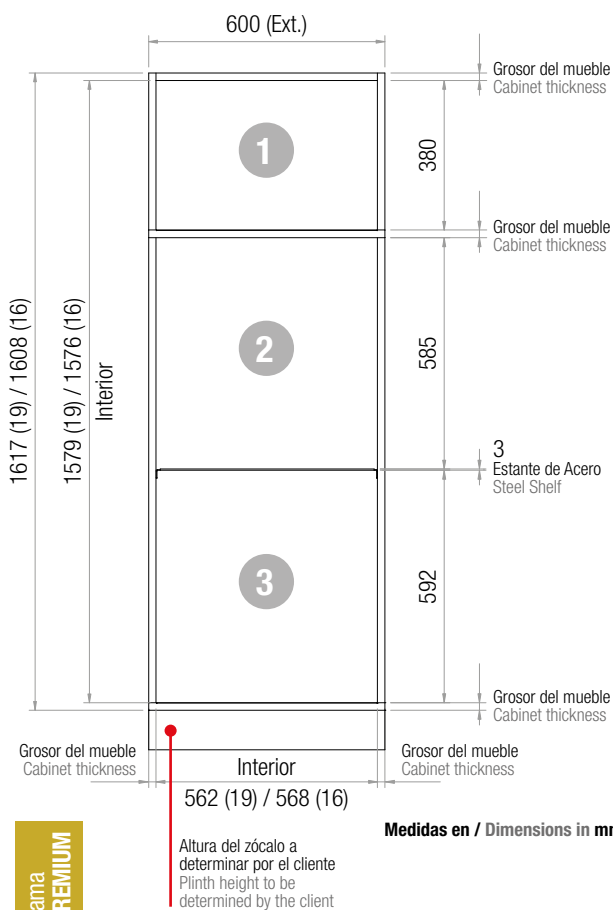

Medidas en / Dimensions in mm

Gama PREMIUM

Ref.	Descripción / Description	Medida Mesurament (mm)
010194	Estante Negro de acero para mueble de 19 mm Black Steel shelf for 19 mm cabinet	562 x 580
010195	Estante Negro de acero para mueble de 16 mm Black Steel shelf for 16 mm cabinet	568 x 580
010193	Ángulo Negro para mueble de 19 mm Black Profile for 19 mm cabinet	L 562
010196	Ángulo Negro para mueble de 16 mm Black Profile for 16 mm cabinet	L 568

L Ángulo en forma de L
L-shaped angle

T Ángulo en forma de T
T-shaped angle

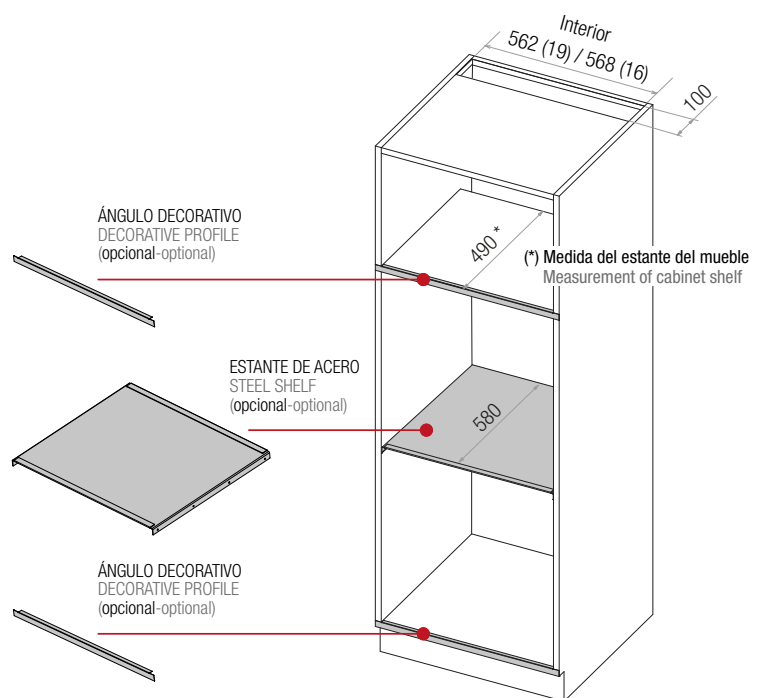

NOTA:
Ángulo decorativo y estante de acero pintados en negro brillante.
Decorative profile and steel shelf painted in glossy black.

Medidas en / Dimensions in mm

Gama TOP

Ref.	Descripción / Description	Medida Mesurament (mm)
010558	Estante Negro de acero para mueble de 19 mm Black Steel shelf for 19 mm cabinet	562 x 580
010559	Estante Negro de acero para mueble de 16 mm Black Steel shelf for 16 mm cabinet	568 x 580
010560	Ángulo Negro INFERIOR para mueble de 19 mm INFERIOR Black Profile for 19 mm cabinet	L 562
010561	Ángulo Negro INFERIOR para mueble de 16 mm INFERIOR Black Profile for 16 mm cabinet	L 568
010562	Ángulo Negro SUPERIOR para mueble de 19 mm SUPERIOR Black Profile for 19 mm cabinet	T 562
010563	Ángulo Negro SUPERIOR para mueble de 16 mm SUPERIOR Black Profile for 16 mm cabinet	T 568



1



PHM-950
Microondas + Grill
Microwave Oven + Grill



PHM-850 / PHM-851
Microondas + Grill
Microwave Oven + Grill

2

Opción A /Option A



**PHT-941, PHTV-942,
PHC-943**
Horno multifunción de 45 cm.
Multifunction Ovens of 45 cm.



PHB-841
Horno multifunción de 45 cm.
Multifunction Ovens of 45 cm.



PCP-9600
Calientaplatos Pando de 15 cm.
Pando plate warmer of 15 cm.



PVMC 15-5 CR
Vinoteca Cajón.
Wine cooler drawer

2

Opción B /Option B



**PHB-961, PHP-962,
PHT-963**
Horno multifunción de 60 cm.
Multifunction Ovens of 60 cm.



**PHB-861, PHTV-862,
PHP-864**
Horno multifunción de 60 cm.
Multifunction Ovens of 60 cm.

3



PVMAVP 60-23
Vinoteca mueble alto
Built-in wine cooler



PLI-7360
Lavavajillas mueble alto
Column built-in dishwasher

Placas de Gas e Inducción

Pando te lo pone fácil.
Para que cocinar se convierta en una experiencia cómoda, intuitiva y sin contratiempos.



Induction & Gas hobs

Pando makes it easy for you.
Turning cooking into a convenient,
intuitive and trouble-free experience.







Placas de Inducción



Induction hobs

Gama TOP

PI-3110

Cristal BISELADO / BEVELED Glass
59 x 52 cm
3 zonas circulares de cocción
3 round cooking zones
p. 221

PI-3150

Cristal BISELADO / BEVELED Glass
59 x 52 cm
2+1 zonas de cocción / Cooking Zones
p. 222

PI-3210

Cristal BISELADO / BEVELED Glass
59 x 52 cm
4 zonas de cocción / Cooking Zones
p. 223

PI-3111

Cristal RECTO / STRAIGHT Glass
59 x 52 cm
3 zonas circulares de cocción
3 round cooking zones
p. 221

PI-3151

Cristal RECTO / STRAIGHT Glass
59 x 52 cm
2+1 zonas de cocción / Cooking Zones
p. 222

PI-3211

Cristal RECTO / STRAIGHT Glass
59 x 52 cm
4 zonas de cocción / Cooking Zones
p. 223



Gama PREMIUM

PI-3100

59 x 52 cm

3 zonas circulares de cocción

3 round cooking zones

p. 228

PI-3200

59 x 52 cm

4 zonas de cocción / Cooking Zones

2 Flexizones BRIDGE

Inductor última generación OCTA G5

p. 229

PI-3300 *AirLink*

59 x 52 cm

4 zonas de cocción / Cooking Zones

2 Flexizones BRIDGE

Inductor última generación OCTA G5

p. 230

PI-3400

81 x 37 cm

**3 zonas circulares de cocción
alineadas**

3 round cooking zones in-line

p. 231

PI-3500 *AirLink*

90 x 52 cm

6 zonas de cocción / Cooking Zones

3 Flexizones BRIDGE

Inductor última generación OCTA G5

p. 233

PI-3800 *AirLink*

78 x 52 cm

6 zonas de cocción / Cooking Zones

3 Flexizones BRIDGE

Inductor última generación OCTA G5

p. 234

PI-DOM

38 x 52 cm

2 zonas de cocción / Cooking Zones

1 Flexizones BRIDGE

Inductor última generación OCTA G5

p. 236

PI-TEP

38 x 52 cm

2 zonas de cocción / Cooking Zones

1 Flexizones BRIDGE

Inductor última generación OCTA G5

p. 237

Gama TOP



Placas de Inducción

Tecnología Pando Flexi y Pando Modular

La gama TOP de placas de inducción de **Pando** incorporan las nuevas tecnologías **Pando Flexi** y **Pando Modular**, ideales para personalizar cada zona de cocción de la cocina.

Los modelos de placas TOP cuentan con acabados en cristal recto y cristal biselado y tres formatos con tecnología Flexi, Flexi/Modular y Modular.

Induction hobs

Pando Flexi and Pando Modular technologies

The TOP range of **Pando** induction hobs incorporating the new **Pando Flexi** and **Pando Modular** technologies, ideal for customising each cooking zone in the kitchen.

The TOP induction range is available in straight and beveled glass designs and three formats with Flexi, Flexi/Modular and Modular technology.



Gama
TOP

PI-3110 Cristal Biselado
Beveled Glass

PI-3111 Cristal Recto
Straight Glass

Placa inducción
Induction hob

59 x 52 cm

Medidas
Measurements

3

Zonas de cocción
Cooking zones

10

Niveles de potencia
Power levels

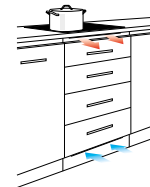

Ventilación recomendada ± 10 mm
Recommended ventilation ± 10 mm

Características / Features

Medidas: 590 x 520mm
 Gran zona de cocción de 290 mm. Ø (Zona C)
 Slider Touch Control General para los 3 Inductores
 Potencia total 7400W
 Indicador de potencia por cada zona de cocción
 Indicador de tiempo
 Ventilador de refrigeración
 Detector automático de recipiente
 Apagado automático de seguridad
 Función de bloqueo infantil
 Control timer – Temporizador
 Indicador de calor residual
 Color Panel de control azul

Dimensions: 590 x 520mm
 Largest cooking area: 290 mm Ø (Zone C)
 3 control Sliders Touch Control
 Total power 7400 W
 Power indicator per cooking zone
 Indicator of cooking time
 Cooling fan
 Automatic detection of pot/pan
 Automatic safety shut-off
 Child lock function
 Timer
 Keep warm function
 Control Panel Colour: Blue

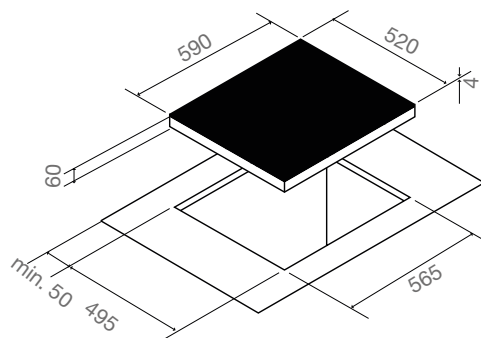

Medidas en / Dimensions in mm

Instalación sobre encimera. Para instalación enrasada del modelo PI-3111, consultar el Manual.

Installation above countertop. For flush-mounted installation of model PI-3111, please refer to the Manual.

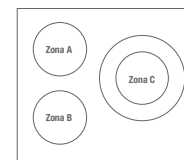

Min cocción Ø100mm en todas las zonas:
Min cooking Ø100mm in all zones:

	Zona A (mm)	Zona B (mm)	Zona C (mm)
Ø Ext:	180	180	290
Power:	1500 W	1500 W	3000 W
Booster:	2100 W	2100 W	3800 W



Gama
TOP

PI-3150 Cristal Biselado
Beveled Glass

PI-3151 Cristal Recto
Straight Glass

Placa inducción
Induction hob

59 x 52 cm

Medidas
Measurements

1

Flexizona BRIDGE
Flexizone BRIDGE

3

Zonas de cocción
Cooking zones

10

Niveles de potencia
Power levels

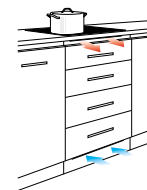

Ventilación recomendada ± 10 mm
Recommended ventilation ± 10 mm

Características / Features

Medidas: 590 x 520mm
Gran zona de cocción de 280 mm. Ø (Zona C)
Slider Touch Control General para los 3 Inductores
Potencia total 7400W
Indicador de potencia por cada zona de cocción
Indicador de tiempo
Ventilador de refrigeración
Detector automático de recipiente
Apagado automático de seguridad
Función de bloqueo infantil
Control timer – Temporizador
Indicador de calor residual
Color Panel de control azul

Dimensions: 590 x 520mm
Largest cooking area: 280 mm Ø (Zone C)
3 control Sliders Touch Control
Total power 7400 W
Power indicator per cooking zone
Indicator of cooking time
Cooling fan
Automatic detection of pot/pan
Automatic safety shut-off
Child lock function
Timer
Keep warm function
Control Panel Colour: Blue

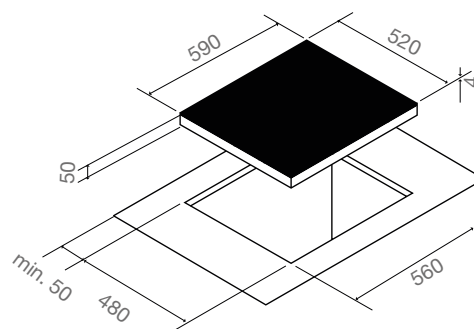

Medidas en / Dimensions in mm

Instalación sobre encimera. Para instalación enrasada del modelo PI-3151, consultar el Manual.
Installation above countertop. For flush-mounted installation of model PI-3111, please refer to the Manual.

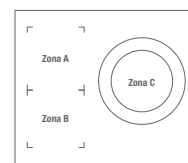

Mín cocción Ø100mm en todas las zonas:
Min cooking Ø100mm in all zones:

	Zona A (mm)	Zona B (mm)	Zona C (mm)
	190x210	190x210	280 Ø
Power:	2000 W	2000 W	2800 W
Booster:	3200 W	3200 W	3700 W

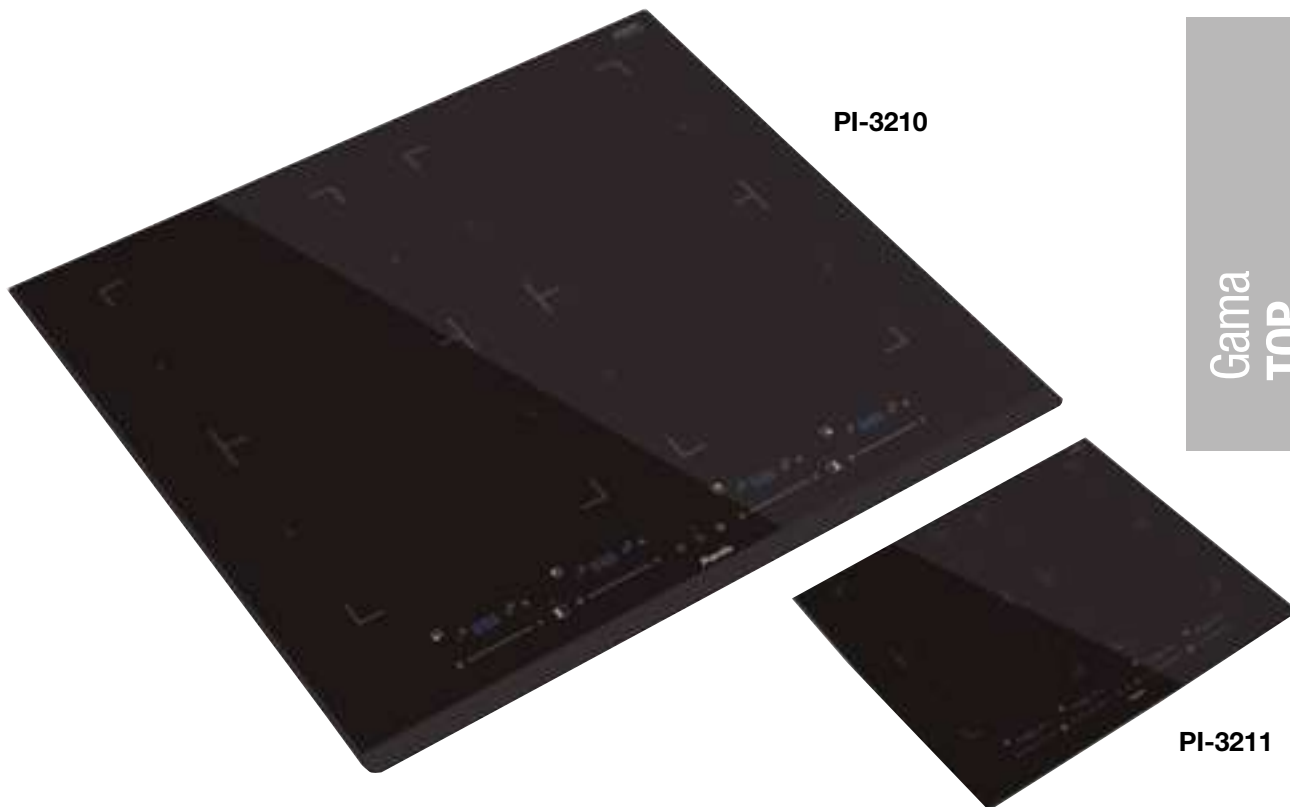

Gama
TOP

PI-3210 Cristal Biselado
Beveled Glass

PI-3211 Cristal Recto
Straight Glass

Placa inducción
Induction hob

59 x 52 cm

Medidas
Measurements

2

Flexizonas BRIDGE
Flexizones BRIDGE

4

Zonas de cocción
Cooking zones

10

Niveles de potencia
Power levels

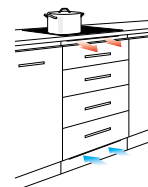

Ventilación recomendada ± 10 mm
Recommended ventilation ± 10 mm

Características / Features

Medidas: 590 x 520mm
Doble zona de cocción BRIDGE (205 x 370 mm)
Slider Touch Control General para los 4 Inductores
Potencia total 7400W
Indicador de potencia por cada zona de cocción
Indicador de tiempo
Ventilador de refrigeración
Detector automático de recipiente
Apagado automático de seguridad
Función de bloqueo infantil
Control timer – Temporizador
Indicador de calor residual
Color Panel de control azul

Dimensions: 590 x 520mm
Double cooking area BRIDGE (205 x 370 mm)
4 control Sliders Touch Control
Total power 7400 W
Power indicator per cooking zone
Indicator of cooking time
Cooling fan
Automatic detection of pot/pan
Automatic safety shut-off
Child lock function
Timer
Keep warm function
Control Panel Colour: Blue

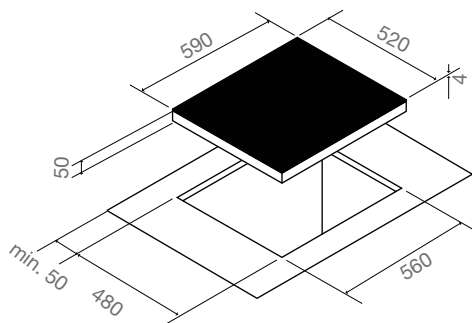

Medidas en / Dimensions in mm

Instalación sobre encimera. Para instalación enrasada del modelo PI-3211, consultar el Manual.
Installation above countertop. For flush-mounted installation of model PI-3111, please refer to the Manual.

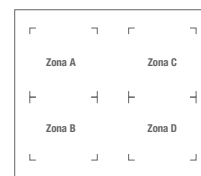

Mín cocción $\varnothing 100$ mm en todas las zonas:
Min cooking $\varnothing 100$ mm in all zones:

	Zona A (mm)	Zona B (mm)	Zona C (mm)	Zona D (mm)
	185x205	185x205	185x205	185x205
Power:	2200 W	2200 W	2200 W	2200 W
Booster:	3300 W	3300 W	3300 W	3300 W

Gama PREMIUM

**Dedícate a lo que
realmente importa**

**Dedicate your
attention to what
really matters**



Más comodidad

Sistema de control inteligente de funcionamiento combinado de campana y placa de inducción.

- Conexión de la iluminación al conectar la placa.
- Puesta en marcha del motor al iniciar el ciclo de cocción de cualquier inductor.
- Aumento y disminución de la potencia del motor de la campana, en función de la exigencia de potencia que se ordene al inductor de la placa.
- Opción de control manual de todas las funciones de la campana.

Total sincronización

RECOMENDACIONES DEL SISTEMA

La campana y la placa de inducción, para su instalación óptima, deberían instalarse en la misma línea de corriente eléctrica.

Sistema Airlink by Pando únicamente es posible, si se realiza el pedido de campana y placa conjuntamente, y se vende exclusivamente vía estudios y tiendas especializadas de mueble de cocina. La campana y la placa deberían sincronizarse, por lo deben ser totalmente compatibles. Consulte las campanas y placas que permiten utilizar el sistema Airlink by Pando. En el 90% de nuestras campanas se puede instalar el sistema Airlink.

More comfort

Smart control system to combine cooker hood and induction hob functions.

- Light turns on automatically when hob is connected.
- Motor starts automatically when cooking cycle begins on any part of the hob.
- Motor speed increases or decreases, depending on the power level set on the cooktop.
- All hood functions can also be controlled manually.

Full synchronization

SYSTEM RECOMMENDATIONS

To ensure an optimal operation, the hood and the induction hob must be installed using the same power line.

The system Airlink by Pando can only be installed into cooker hoods and induction hobs bought together in the same purchase order. The Airlink by Pando system is sold exclusively through designers and premium kitchen studios. Hood and hob must be synchronized, so they ought to be compatible. Please check which cooker hoods and induction hobs can use the system Airlink by Pando. This Airlink system can be installed in 90% of our cooker hoods.

Gama
PREMIUM



POWER

Placas de Inducción Induction hobs



CRISTAL CERÁMICO KERASPECTRUM® KERASPECTRUM CERAMIC GLASS®

- 1 SISTEMA BRIDGE - FLEXIZONA**
Esta función permite sincronizar las zonas de cocción para ofrecer un calor más uniforme. Ideal para sartenes de gran tamaño, besugeros, planchas y paellas de hasta 40 cm.
- 2 CONTROL SLIDER TOUCH CONTROL**
Sistema táctil de selección de las diferentes funciones y temperaturas. Incluye el sistema Slider que facilita el uso de la placa.
- 3 PROGRAMAS AUTOMÁTICOS DE COCCIÓN**
Para que el acto de cocinar se convierta en una experiencia cómoda, intuitiva y sin contratiempos.
- 4 AIRLINK**
Sistema de control inteligente de funcionamiento combinado de campana y placa de inducción.

BRIDGE SYSTEM - FLEXIZONE

This function allows to synchronize the different cooking areas to provide a uniform heat. Ideal for Paella, large pots, pans and/or plates.

CONTROL SLIDER TOUCH CONTROL

Tactile control system to select the different functions and temperatures. Includes a slider system that makes it very easy to use.

PRE-ESTABLISHED COOKING PROGRAMS

Simple to use. Converts cooking into a great, hassle free experience, even for the unexperienced cook.

AIRLINK

Smart control system that combines the control panels of your cooker hood and your induction cooktop into one.



Gama
PREMIUM

PI-3100 **Cristal Biselado** Beveled Glass

Placa inducción Induction hob

59 x 52 cm

Medidas
Measurements

3

Zonas de cocción
Cooking zones

11

Niveles de potencia
Power levels

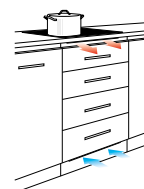

Ventilación recomendada ± 10 mm
Recommended ventilation ± 10 mm

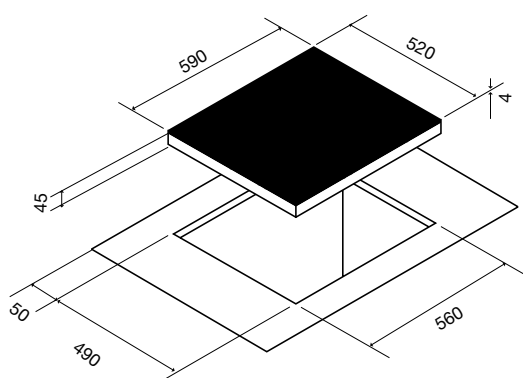

Medidas en / Dimensions in mm

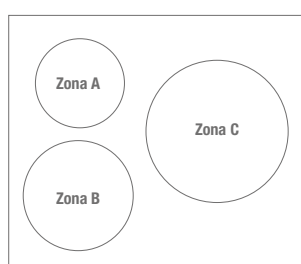

Medidas: 590x520mm	Dimensions: 590x520mm
Cristal cerámico Keraspectrum® Biselado	Beveled Keraspectrum® ceramic glass
1 Slider Touch Control para los 3 Inductores	1 Slider General Touch Control for 3 induction rings
Potencia total 6700W	Total power 6700W
Indicador del tiempo	Time indicator
Indicador de potencia	Power indicator
Botón mantener caliente 72°C	Keep warm function 72°C
Indicador de zona activa / modo temporizador	Active zone indicator / timer mode
Temporizador Stop & Go	Stop&Go / Pause key
Detección de recipiente	Automatic detection of recipient
Cocción automática	Automatic cooking
Función de bloqueo	Child lock function
Control timer - Temporizador	Timer
Indicador de Calor Residual	Keep warm function

(mm)	Zona A	Zona B	Zona C
Ø Ext:	180	220	280
Ø Mín:	90	100	110
Ø Máx:	200	240	300
Power:	1100 W	2300 W	2300 W
Booster:	1400 W	3000 W	3000 W

Gama
PREMIUM

PI-3200 Cristal Biselado
Beveled Glass

Placa inducción
Induction hob

Con inductor EGO de última generación OCTA G5
With EGO inductor of latest generation OCTA G5

59 x 52 cm
Medidas
Measurements

2
Flexizonas BRIDGE
Flexizones BRIDGE

4
Zonas de cocción
Cooking zones

14
Niveles de potencia
Power levels

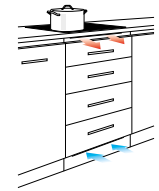

Ventilación recomendada ± 10 mm
Recommended ventilation ± 10 mm

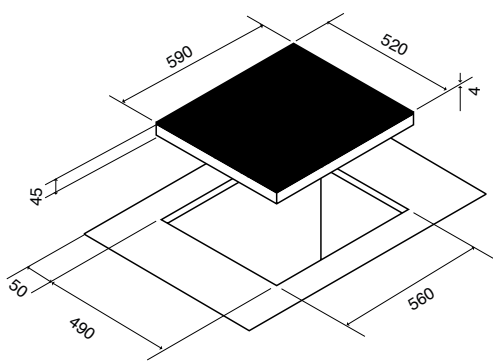

Medidas en / Dimensions in mm

Ideal para recipientes con un Ø máximo de 400 mm (tipo paella)
Ideal for recipients with a maximum Ø of maximum 400 mm (paella type).

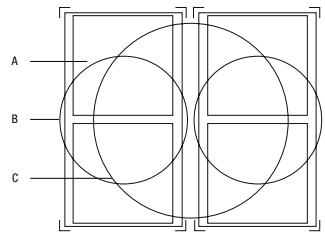

Medidas: 590x520mm	Dimensions: 590x520mm
Cristal cerámico Keraspectrum® Biselado	Beveled Keraspectrum® ceramic glass
Control inductor/campana display azul	Blue LED display to control induction / hood
4 control Sliders Touch Control	4 control Sliders Touch Control
Potencia total 7400W	Total power 7400W
3 Programas automáticos de cocción 42°C, 72°C, 94°C	3 automatic cooking programs 42°C, 72°C, 94°C
Indicador conservación de calor	Indicator heat conservation
Control Timer - Temporizador	Timer
Indicador de tiempo	Indicator of cooking time
Temporizador Stop & Go	Stop&Go / Pause key
Función bloqueo	Child lock function
Indicador de puesta en marcha	Startup indicator
Indicador de zona activa	Active zone indicator
Detección automática de la función bridge	Automatic detection of bridge function
Detección automática de recipiente	Automatic detection of recipient
Cocción automática	Automatic cooking function
Función Grill	Grill function
Last Time Automático (después de 5 min. de su uso)	Automatic Last Time function (5 min.)

(mm)	Zona A	Zona B	Zona C
□ Ext:	220x180	220x360	460x360
□ Mín:	100	135	330
□ Máx:	180	220	400

Power: 2100W
Booster: 2600 W
Super Booster: 3700W

Gama
PREMIUM

PI-3300 **Cristal Biselado** Beveled Glass

AirLink | **BRIDGE**

Placa inducción
Induction hob

Con inductor EGO de última generación OCTA G5
With EGO inductor of latest generation OCTA G5

59 x 52 cm

Medidas
Measurements

2

Flexizonas BRIDGE
Flexizones BRIDGE

4

Zonas de cocción
Cooking zones

14

Niveles de potencia
Power levels

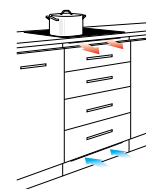

Ventilación recomendada ± 10 mm
Recommended ventilation ± 10 mm

AirLink

Sistema de control inteligente de funcionamiento combinado de campana y placa de inducción.
Smart control system for combined management of hood and induction hob.

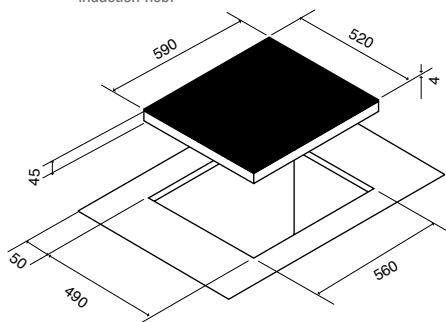

Medidas en / Dimensions in mm

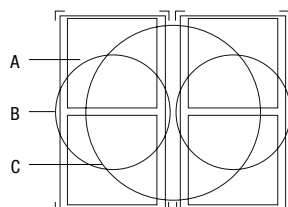

(mm)	Zona A	Zona B	Zona C
<input type="checkbox"/> Ext:	220x180	220x360	460x360
<input type="checkbox"/> Mín:	100	135	330
<input type="checkbox"/> Máx:	180	220	400

Power: 2100W | Booster: 2600 W
Super Booster: 3700W

Medidas: 590x520mm

Cristal cerámico Keraspectrum® Biselado

Control inductor/campana display azul

4 control Sliders Touch Control

Potencia total 7400W

3 Programas automáticos de cocción
42°C, 72°C, 94°C

Indicador conservación de calor

Control Timer - Temporizador

Indicador de tiempo

Temporizador Stop & Go

Función bloqueo

Indicador de puesta en marcha

Indicador de zona activa

Detección automática de la función bridge

Detección automática de recipiente

Cocción automática

Función Grill

Last Time Automático (después de 5 min. de su uso)

Dimensions: 590x520mm

Beveled Keraspectrum® ceramic glass

Blue LED display to control induction / hood

4 control Sliders Touch Control

Total power 7400W

3 automatic cooking programs
42°C, 72°C, 94°C

Indicator heat conservation

Timer

Indicator of cooking time

Stop&Go / Pause button

Child lock function

Startup indicator

Active zone indicator

Automatic detection of bridge function

Automatic detection of recipient

Automatic cooking function

Grill function

Automatic Last Time function (5 min.)

Panel de control de la campana

Control panel for the cooker hood

Indicador de potencia	Power level indicator
Botón Timer (-, +)	Timer (-, +)
Iluminación Campana on/off	Cooker hood Light on/off
Botón Automático	Automatic button
Botón Stop & Go	Stop & Go key

Gama
PREMIUM



PI-3400 Cristal Biselado
Beveled Glass

Placa inducción
Induction hob

81 x 37 cm
Medidas
Measurements

3
Zonas de cocción
Cooking zones

11
Niveles de potencia
Power levels

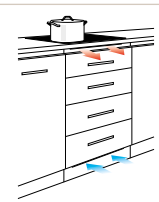

Ventilación recomendada ± 10 mm
Recommended ventilation ± 10 mm

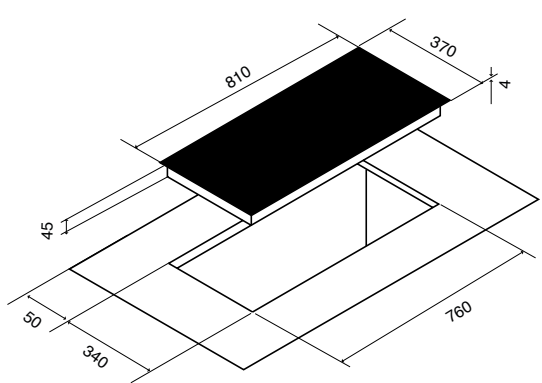

Medidas en / Dimensions in mm

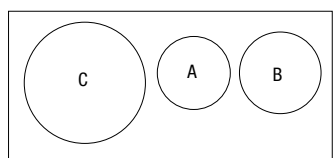

Medidas: 810x370mm	Dimensions: 810x370mm
Cristal cerámico Keraspectrum® Biselado	Beveled Keraspectrum® ceramic glass
1 Slider Touch Control General	1 Slider General Touch Control
Potencia total 6400W	Total power 6400W
Indicador de tiempo	Indicator of cooking time
Botón (mantener caliente) 72°C	Keep warm function 72°C
Indicador de zona activa / modo temporizador	Timer
Temporizador Stop & Go	Stop&Go / Pause button
Detección de recipiente	Automatic detection of recipient
Cocción automática	Automatic cooking function
Función de bloqueo	Child lock key
Indicador de Calor Residual	Keep warm function

	Zona A (mm)	Zona B (mm)	Zona C (mm)
Ø Ext:	180	200	300
Ø Min:	90	90	110
Ø Máx:	200	220	300
Power:	1100 W	1400 W	2300 W
Booster:	1400 W	2000 W	3000 W



Medidas: 900 x 520 mm	Dimensions: 900 x 520 mm
Cristal cerámico Keraspectrum® Biselado	Beveled Keraspectrum® ceramic glass
6 control Sliders Touch Control	6 control Sliders Touch Control
Potencia total 11000W	Total power 11000W
3 Programas automáticos de cocción 42°C, 72°C, 94°C	3 automatic cooking programs 42°C, 72°C, 94°C
Indicador conservación de calor	Indicator heat conservation
Control Timer - Temporizador	Timer
Indicador de tiempo	Indicator of cooking time
Temporizador Stop & Go	Stop&Go / Pause button
Función bloqueo	Child lock function
Indicador de puesta en marcha	Startup indicator
Indicador de zona activa	Active zone indicator
Detección automática de la función bridge	Automatic detection of bridge function
Detección automática de recipiente	Automatic detection of recipient
Cocción automática	Automatic cooking function
Función Grill	Grill function
Last Time Automático (después de 5 min. de su uso)	Automatic Last Time function (5 min.)

Panel de control de la campana Control panel for the cooker hood

Indicador de potencia	Power level indicator
Botón Timer (-, +)	Timer (-, +)
Iluminación Campana on/off	Cooker hood Light on/off
Botón Automático	Automatic button
Botón Stop & Go	Stop & Go key

Gama
PREMIUM



PI-3500 Cristal Biselado
Beveled Glass

AirLink | BRIDGE

Placa inducción
Induction hob

Con inductor EGO de última generación OCTA G5
With EGO inductor of latest generation OCTA G5

90 x 52 cm
Medidas
Measurements

3
Flexizonas BRIDGE
Flexizones BRIDGE

6
Zonas de cocción
Cooking zones

14
Niveles de potencia
Power levels

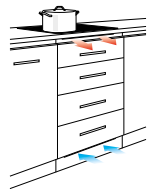

Ventilación recomendada ± 10 mm
Recommended ventilation ± 10 mm

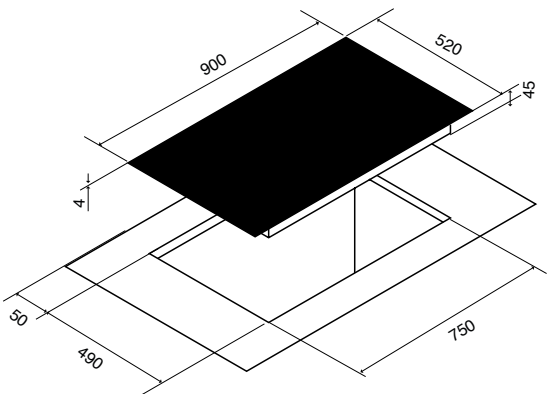

Medidas en / Dimensions in mm

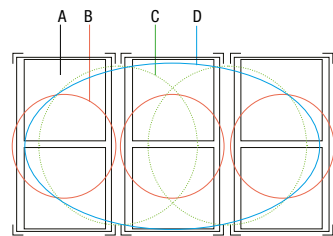

	Zona A (mm)	Zona B (mm)	Zona C (mm)	Zona D (mm)
□ Ext:	220x180	220x360	460x360	700x360
□ Mín:	100	135	330	---
□ Máx:	180	220	400	700x360
Power:	2100 W			
Booster:	2600 W			
Super Booster:	3700 W			

AirLink

Sistema de control inteligente de funcionamiento
combinado de campana y placa de inducción.
Smart control system for combined management of hood and
induction hob.

Gama
PREMIUM



PI-3800 Cristal Biselado
Beveled Glass

AirLink | BRIDGE

Placa inducción
Induction hob

Con inductor EGO de última generación OCTA G5
With EGO inductor of latest generation OCTA G5

78 x 52 cm

Medidas
Measurements

3

Flexizonas BRIDGE
Flexizones BRIDGE

6

Zonas de cocción
Cooking zones

14

Niveles de potencia
Power levels

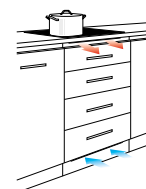

Ventilación recomendada ± 10 mm
Recommended ventilation ± 10 mm

AirLink

Sistema de control inteligente de funcionamiento combinado de campana y placa de inducción.
Smart control system for combined management of hood and induction hob.

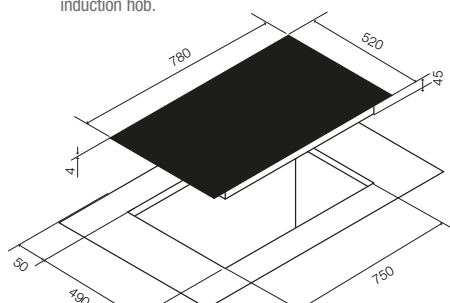

Medidas en / Dimensions in mm

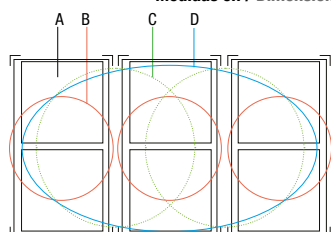

(mm)	Zona A	Zona B	Zona C	Zona D
□ Ext:	220x180	220x360	460x360	660x360
□ Mín:	100	135	330	---
□ Máx:	180	220	360	660x360

Power: 2100W | Booster: 2600 W
Super Booster: 3700W

Medidas: 780 x 520mm

Cristal cerámico Keraspectrum® Biselado

6 control Sliders Touch Control

Potencia total 11000W

6 Zonas 4 Flexizonas Bridge

3 Programas automáticos de cocción

42°C, 72°C, 94°C

Indicador conservación de calor

Control Timer - Temporizador

Botón timer

Indicador de tiempo

Botón Stop & Go

Función bloqueo

Indicador de puesta en marcha

Indicador de zona activa

Detección automática de la función bridge

Detección automática de recipiente

Cocción automática

Función Grill

Last Time Automático (después de 5 min. de su uso)

Dimensions: 780 x 520mm

Beveled Keraspectrum® ceramic glass

6 control Sliders Touch Control

Total power 11000W

6 Zones / 4 Bridge Flexizones

3 automatic cooking programs

42°C, 72°C, 94°C

Indicador heat conservation

Timer

Timer keys

Indicator of cooking time

Stop&Go / Pause button

Child lock key

Startup indicator

Indicator of active zones

Automatic detection of bridge function

Automatic detection of recipient

Automatic cooking function

Grill function

Automatic Last Time function (5 min.)

Panel de control de la campana
Control panel for the cooker hood

Indicador de potencia	Power level indicator
Botón Timer (-, +)	Timer (-, +)
Iluminación Campana on/off	Cooker hood Light on/off
Botón Automático	Automatic button
Botón Stop & Go	Stop & Go key

Gama
PREMIUM



PI-4-ACC

Plancha rectangular
Rectangular Cooking plate

43 x 23 x 3,5 cm
Medidas
Mesuraments

Optimizada para zonas BRIDGE

Optimized for BRIDGER zones



Diseño personalizado **Pando** en hierro fundido con revestimiento esmaltado que optimiza la distribución y la eficiencia del calor del inductor. La zona de Plancha grande es ideal para preparar todo tipo de alimentos (carne, huevos revueltos, panqueques...). La zona de Grill permite marcar un filete o preparación de verduras a tiras, pescados, mariscos, etc...

Pando personalised design in cast iron to optimise induction heat distribution and efficiency. The large griddle area is ideal for preparing all kinds of food (meat, scrambled eggs, pancakes, etc.) The grill area enables you to sear filets or to cut vegetables or to prepare fish, shellfish, shrimps, etc.

De gran estabilidad al incorporar 4 soportes protectores termo resistente que protegen la placa de inducción de posibles rayadas, evitando también desplazamientos mientras se está cocinando. Su peso es de 4,7 Kg.

It is very stable as it incorporates 4 thermo-resistant protective supports that protect the induction hob from possible scratches, also avoiding displacements while it is cooking. Its weight is 4.7 Kg.



Medidas: 430 x 230 x 35 mm

Dimensions: 430 x 230 x 35 mm

Asas laterales ergonómicas

Ergonomic side handles

Superficie de total de cocción XL 700 cm²

XL total cooking surface 700 cm²

Superficie de la parrilla 350 cm²

Grill surface area 350 cm²

Superficie de plancha 342 cm²

Griddle pan surface area 342 cm²

Para la correcta utilización, accionar la función de parrilla que disponen las placas de inducción **Pando** (Mod. PI-3200 / PI-3300 / PI-3500 / PI-3800 / PI-DOM)

For correct usage, turn on the grill function of the **Pando** induction hob. (Models PI-3200 / PI-3300 / PI-3500 / PI-3800 / PI-DOM)

Coincide a la perfección con el tamaño y forma de los inductores

Perfect match with the size and shape of the induction zones

Esmalte específico de calidad alimentaria

Special food-quality coating

Limpieza: A mano con una esponja suave y agua jabonosa

Cleaning: Hand-washed using a mild sponge and soapy water

Gama
PREMIUM



PI-DOM **Cristal Biselado** Beveled Glass

Placa inducción
Induction hob

Con inductor EGO de última generación OCTA G5
With EGO inductor of latest generation OCTA G5

38 x 52 cm

Medidas
Measurements

1

Flexizona BRIDGE
Flexizone BRIDGE

2

Zonas de cocción
Cooking zones

14

Niveles de potencia
Power levels

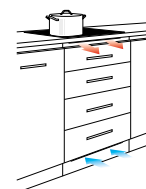

Ventilación recomendada ± 10 mm
Recommended ventilation ± 10 mm

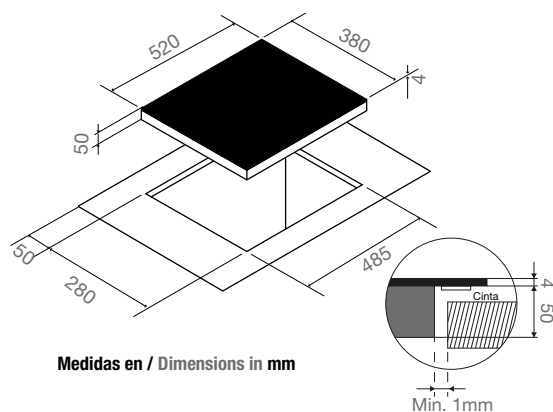

Medidas en / Dimensions in mm

Medidas: 380x520mm

Cristal cerámico Biselado

Control inductor display azul

2 control Sliders Touch Control

Potencia total 3700W

3 Programas automáticos de cocción

42°C, 72°C, 94°C

Indicador conservación de calor

Control Timer – Temporizador

Indicador de tiempo

Temporizador Stop & Go

Función bloqueo

Indicador de puesta en marcha

Indicador de zona activa

Detección automática de la función bridge

Detección automática de recipiente

Cocción automática

Función Grill

Dimensions: 380x520 mm

Beveled ceramic glass

Blue LED display control

2 control Sliders Touch Control

Total power 3700 W

3 automatic cooking programs

42°C, 72°C, 94°C

Indicator heat conservation

Timer

Indicator of cooking time

Stop&Go / Pause key

Child lock function

Startup indicator

Active zone indicator

Automatic detection of bridge function

Automatic detection of recipient

Automatic cooking function

Grill function

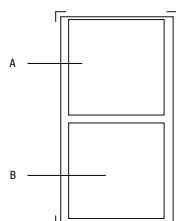

(mm)	Zona A	Zona B
□ Ext:	220x180	220x180
□ Mín:	100	100
□ Máx:	180	180
Power:	2100 W	
Booster:	2650 W	
Super Booster:	3700 W	

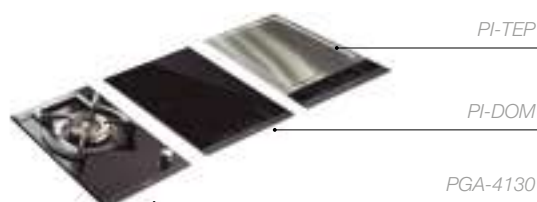

Distancia mínima de encastre entre productos: 10 cm
Minimum built-in distance between products: 10 cm

Gama
PREMIUM



PI-TEP Cristal Biselado
Beveled Glass

Placa inducción TEPPAN YAKI
TEPPAN YAKI Induction hob

Con inductor EGO de última generación OCTA G5
With EGO inductor of latest generation OCTA G5

38 x 52 cm
Medidas
Measurements

1
Flexizona BRIDGE
Flexizone BRIDGE

2
Zonas de cocción
Cooking zones

10
Niveles de potencia
Power levels

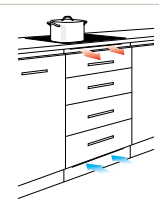

Ventilación recomendada ± 10 mm
Recommended ventilation ± 10 mm

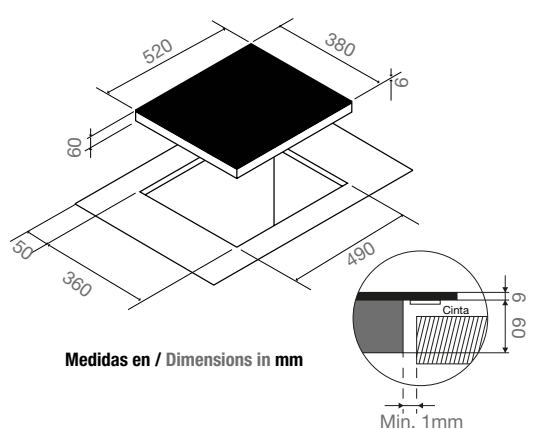

Medidas en / Dimensions in mm

Medidas: 380x520mm	Dimensions: 380x520mm
Rango de temperaturas 50°C a 220°C	Temperature range 50°C to 220°C
Cristal cerámico Biselado	Beveled ceramic glass
Control display azul	Blue LED display to control
2 control Sliders Touch Control	2 control Sliders Touch Control
Potencia total 2800W	Total power 2800 W
Temporizadores independientes por zona	Independent timers per zone
Indicador conservación de calor	Indicator heat conservation
Cocción automática: Carne y pescado	Automatic cooking: Meat and fish
Control Timer – Temporizador	Timer
Indicador de tiempo	Indicator of cooking time
Temporizador Stop & Go	Stop&Go / Pause key
Función bloqueo	Child lock function
Indicador de puesta en marcha	Startup indicator
Indicador de zona activa	Active zone indicator
Bridge	Automatic detection of bridge function
Función de limpieza	Cleaning function
Recordatorio últimos ajustes	Reminder last settings
Detección de desbordamiento	Overflow detection

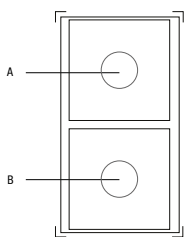

(mm)	Zona A	Zona B
Ø	145	145
Power:	2 x 1400 W	
Total Power:	2800 W	

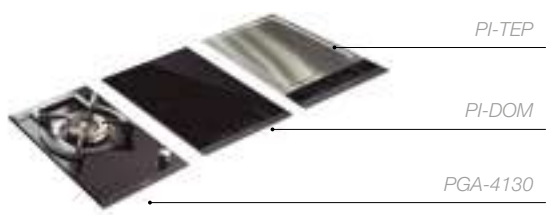

Distancia mínima de encastre entre productos: 10 cm
Minimum built-in distance between products: 10 cm

Placas de
Gas
Gas
hobs

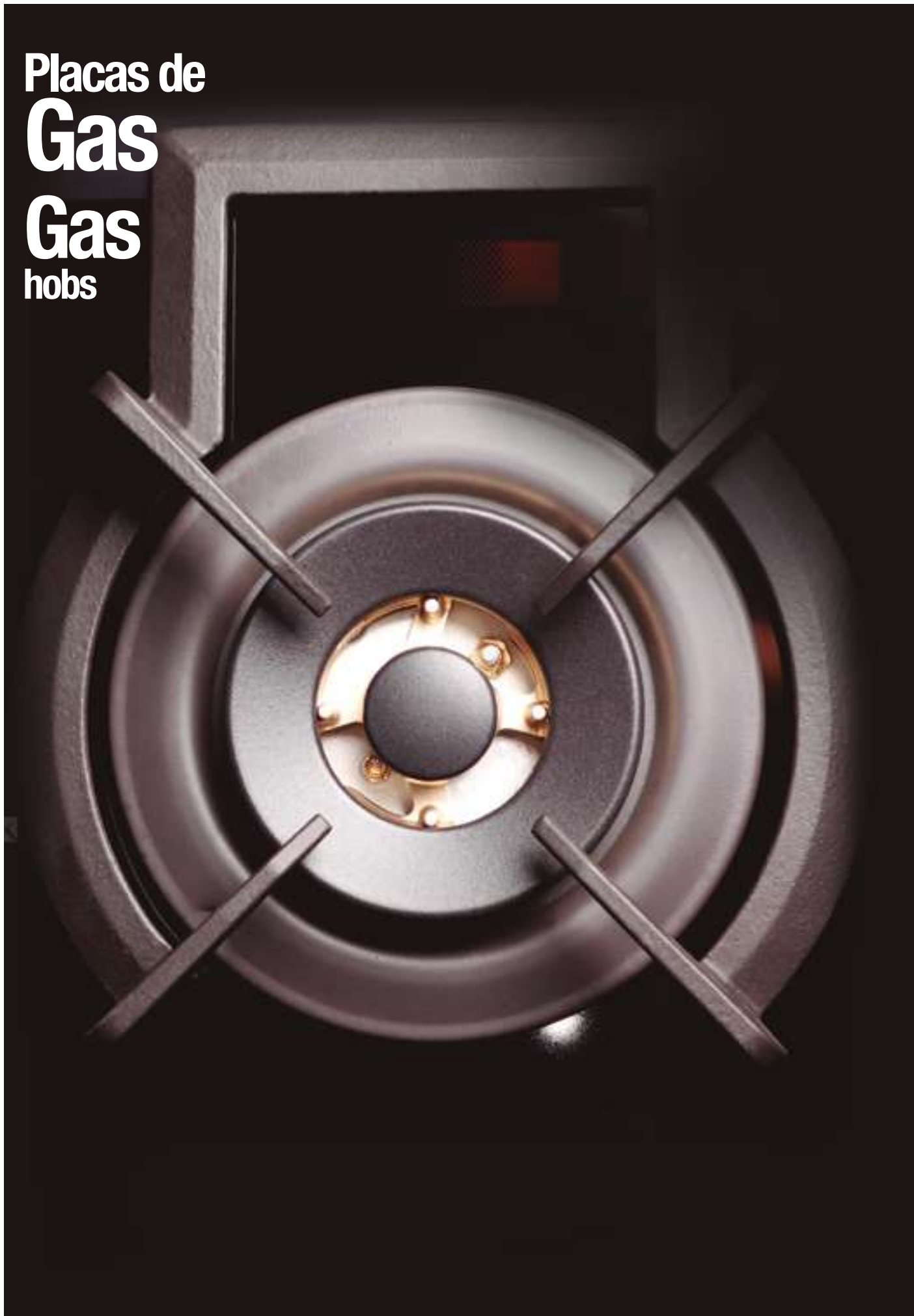



Gama PREMIUM

PGA-4130

31 x 51 cm
1 zona de cocción
1 round cooking zone
p. 240

PGA-4261

62 x 51 cm
3 zonas de cocción
3 round cooking zones
p. 241

PGA-4371

71 x 51 cm
5 zonas de cocción
5 round cooking zones
p. 242

PGA-4492

88 x 51 cm
5 zonas de cocción
5 round cooking zones
p. 243

Gama
PREMIUM



PGA-4130 **Cristal Biselado** Beveled Glass

Placa de gas
Gas hob

31 x 51 cm

Medidas
Measurements

1

Zonas de cocción
Cooking zones

6 KW

Potencia Máxima
Total Power



Opción mandos en negro
Black control option
Ref. 010650

Medidas: 310x510 mm	Dimensions: 310x510 mm
Cristal Vitroceramico biselado	Beveled Vitroceraamic Glass
Potencia máxima 6,0 Kw	Maximum power 6,0 Kw
Placa de cocción a gas (natural o butano/propano)	Gas hob (natural or butane/propane)
Acabado sin marco exterior	Finishing without external frame
Mando frontal incorporado	Built-in front control knob
Parrilla de hierro fundido con soporte WOK	Cast iron grill with built-in wok stand
1 quemador función Dual doble corona (135 mm)	1 Double-crown burner with dual function (135 mm)
Autoencendido integrado en quemador y accionado por cada mando	Auto ignition built into each burner and operated by each control
Dispositivo de seguridad con bloqueo automatico	Includes automatic safety lock
Seguridad por termopar integrada en quemador individual	Safety thermocouple built into individual burner

Preparadas de serie para Gas Natural (G20), como accesorios se incluyen inyectores para transformación a Gas Butano (G30)
Standard prepared for Natural Gas (G20), as accessories include injectors for processing to Gas Butano (G30)

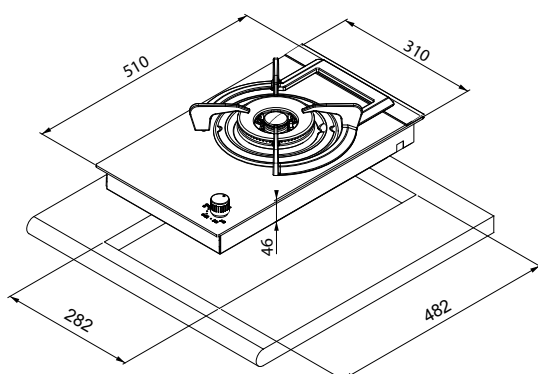

Medidas en / Dimensions in mm

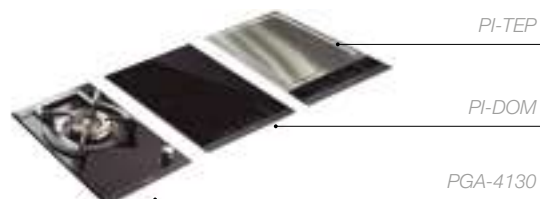

Distancia mínima de encastre entre productos: 10 cm
Minimum built-in distance between products: 10 cm

Gama
PREMIUM



PGA-4261

Cristal Biselado
Beveled Glass

Placa de gas
Gas hob

62 x 51 cm

Medidas
Measurements

3

Zonas de cocción
Cooking zones

7,8 KW

Potencia Máxima
Total Power



Opción mandos en negro
Black control option
Ref. 010650

quemador triple corona
triple crown ring

Ø133 mm
4,0 Kw

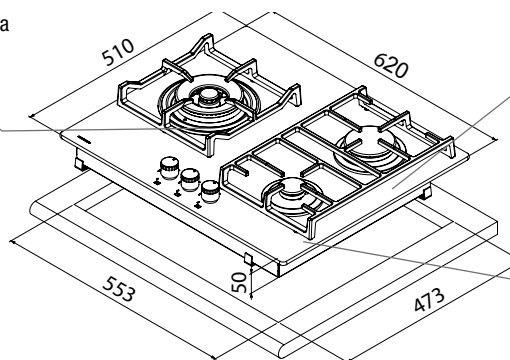

Ø100 mm
2,8 Kw

Ø55 mm
1,0 Kw

Medidas en / Dimensions in mm

Medidas: 620x510 mm	Dimensions: 620x510 mm
Cristal Vitroceramico biselado	Beveled Vitroceramic Glass
Potencia máxima 7,8 Kw	Maximum power 7,8 Kw
Placa de cocción a gas (natural o butano/propano)	Gas hob (natural or butane/propane)
Acabado sin marco exterior	Finishing without external frame
Mandos frontales incorporados	Built-in front control knobs
Parrillas de hierro fundido	Cast iron grills
Autoencendido integrado en quemador y accionado por cada mando	Auto ignition built into each burner and operated by each control
Dispositivo de seguridad con bloqueo automatico	Includes automatic safety lock
Seguridad por termopar integrada en quemador individual	Safety thermocouple built into individual burner

Preparadas de serie para Gas Natural (G20), como accesorios se incluyen inyectores para transformación a Gas Butano (G30)
Standard prepared for Natural Gas (G20), as accessories include injectors for processing to Gas Butano (G30)

Gama
PREMIUM



PGA-4371

Cristal Biselado
Beveled Glass

Placa de gas
Gas hob



71 x 51 cm

Medidas
Measurements

5

Zonas de cocción
Cooking zones

10,95 KW

Potencia Máxima
Total Power



Opción mandos en negro
Black control option
Ref. 010650

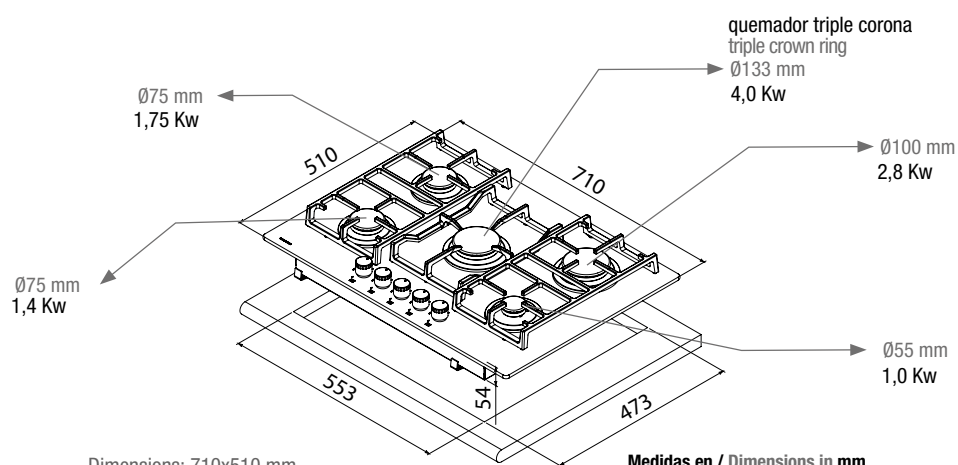

Medidas: 710x510 mm

Cristal Vitroceramico biselado

Potencia máxima 10,95 kW

Placa de cocción a gas (natural o butano/propano)

Acabado sin marco exterior

Mandos frontales incorporados

Parrillas de hierro fundido

Autoencendido integrado en quemador y accionado por cada mando

Dispositivo de seguridad con bloqueo automatico

Seguridad por termopar integrada en quemador individual

Dimensions: 710x510 mm

Beveled Vitroceramic Glass

Maximum power 10,95 kW

Gas hob (natural or butane/propane)

Finishing without external frame

Built-in front control knobs

Cast iron grills

Auto ignition built into each burner and operated by each control

Includes automatic safety lock

Safety thermocouple built into individual burner

Medidas en / Dimensions in mm

Preparadas de serie para Gas Natural (G20), como accesorios se incluyen inyectores para transformación a Gas Butano (G30)
Standard prepared for Natural Gas (G20), as accessories include injectors for processing to Gas Butano (G30)

Gama
PREMIUM



PGA-4492 **Cristal Biselado**
Beveled Glass

Placa de gas
Gas hob



88 x 51 cm Medidas Measurements	5 Zonas de cocción Cooking zones	10,70 KW Potencia Máxima Total Power
--	---	---



Opción mandos en negro
Black control option
Ref. 010650

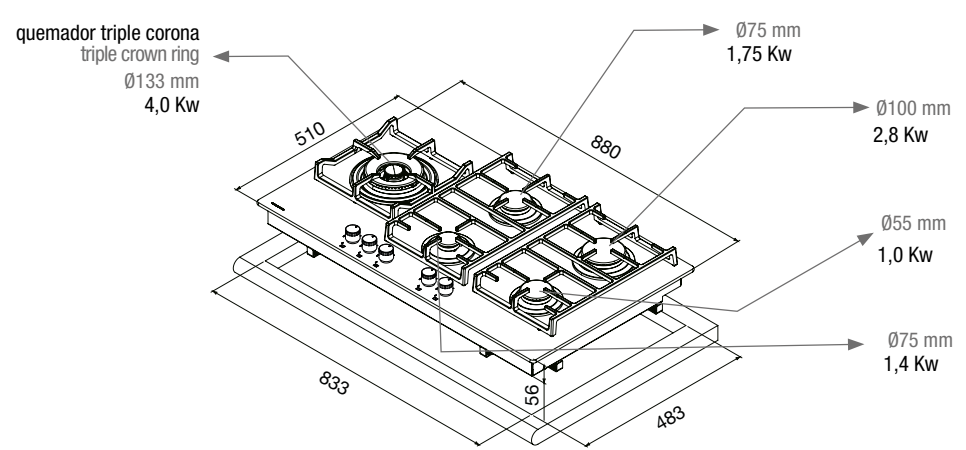

Medidas: 880x510 mm	Dimensions: 880x510 mm
Cristal Vitroceramico biselado	Beveled Vitroceramic Glass
Potencia máxima 10,70 kW	Maximum power 10,70 kW
Placa de cocción a gas (natural o butano/propano)	Gas hob (natural or butane/propane)
Acabado sin marco exterior	Finishing without external frame
Mandos frontales incorporados	Built-in front control knobs
Parrillas de hierro fundido	Cast iron grills
Autoencendido integrado en quemador y accionado por cada mando	Auto ignition built into each burner and operated by each control
Dispositivo de seguridad con bloqueo automatico	Includes automatic safety lock
Seguridad por termopar integrada en quemador individual	Safety thermocouple built into individual burner

Medidas en / Dimensions in mm

Preparadas de serie para Gas Natural (G20), como accesorios se incluyen inyectores para transformación a Gas Butano (G30)
Standard prepared for Natural Gas (G20), as accessories include injectors for processing to Gas Butano (G30)

Lavavajillas integrables

Los lavavajillas **Pando** se integran perfectamente al diseño de cualquier cocina sin alterar su armonía. Gracias a su sistema de puerta deslizante, el lavavajillas **Pando** queda perfectamente adaptado con el resto de mobiliario, facilitando su instalación, ya que no tendrá que recortar el zócalo.



Dishwashers integrated

Pando Dishwashers integrate perfectly into the seamless design of any kitchen without altering its harmony.

Thanks to its sliding door system, **Pando** Dishwashers perfectly adapt to the rest of the kitchen and allow easy installation and operation without the need to adjust the plinth.



Lavavajillas de integración panelable
Fully-integrated dishwashers



PLT-7461

**Anchura / Size: 60 cm
Natural Dry System**

p.248



Altura de la puerta
Door height

PLT-7462 XXL

Anchura / Size: 60 cm
Natural Dry System
p. 250

PLB-7161

Anchura / Size: 60 cm
Natural Dry System
p. 252

PLB-7146

Anchura / Size: 45 cm
Natural Dry System
p. 254

**Pensando en
todos los detalles**

**Considering
every detail**

Flexible / Flexibility



1

TERCERA BANDEJA PARA CUBIERTOS

Totalmente modular para mayor comodidad en la colocación de cubiertos y utensilios de cocina.

THIRD DRAWER FOR CUTLERY

Completely modular to provide various loading solutions for cutlery to meet your particular needs.

3

DOBLE BANDEJA ABATIBLE

Permite aumentar la capacidad y colocar tazas o vasos pequeños

DOUBLE TRAY FOLDABLE

Increases capacity by providing extra space for small glasses and cups.

4

INTERIORES FLEXIBLES ADAPTABLES

Diseñados para facilitar la distribución de elementos de cualquier tamaño.

FLEXIBLE INTERIOR DESIGN

Facilitates placement of pots, plates and dishes of any size and form.

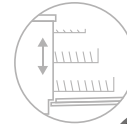
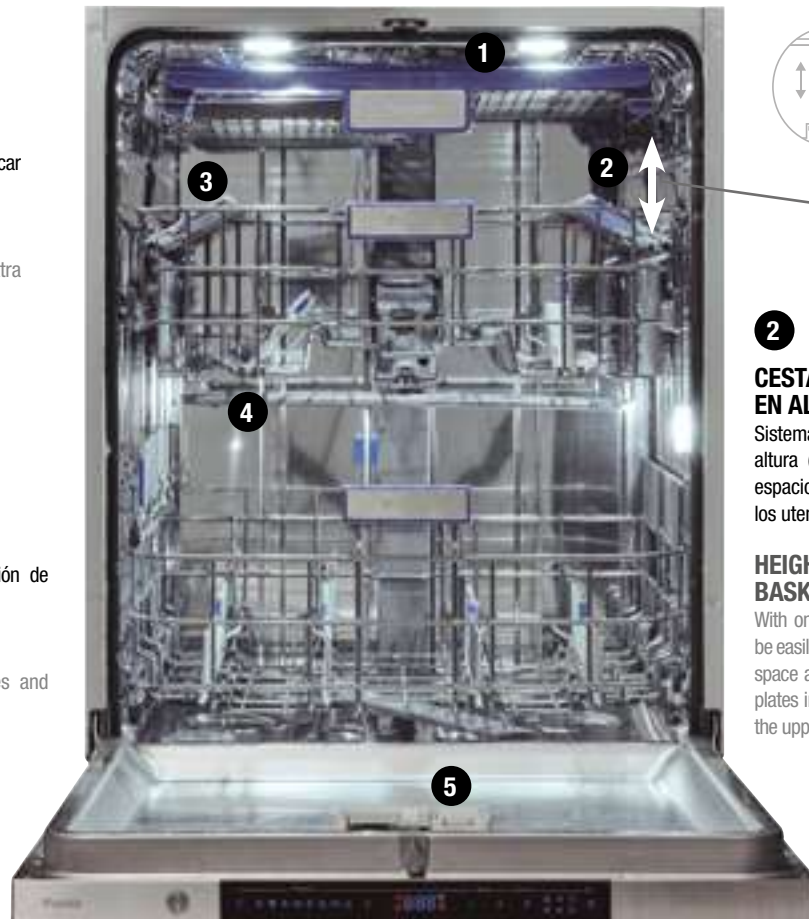

2

CESTA SUPERIOR REGULABLE EN ALTURA

Sistema de regulación a 2 niveles de altura (+/- 5cm ...) que le facilitará el espacio necesario para la colocación de los utensilios de mayor tamaño.

HEIGHT-ADJUSTABLE UPPER BASKET

With only one "click" the upper Basket can be easily adjusted (+/- 5cm ...) to offer more space and flexibility to load larger pots and plates in the lower basket, or tall glasses in the upper Basket.



5

SISTEMA DUAL DE LAVADO

Nos permite seleccionar la zona de lavado que necesitamos, superior, inferior o ambas, sin necesidad de cargar completamente el lavavajillas

DUAL ZONE WASHING SYSTEM

Allows to choose the area of cleaning as we need it: upper area only, lower area only or both.

Adaptable / Adaptable



MÁXIMA COMODIDAD

Interiores diseñados para facilitar la distribución de elementos de cualquier tamaño

MAXIMUM COMFORT

To facilitate the distribution of silverware of any size and form.



DOBLE BANDEJA ADAPTABLE

Permite aumentar la capacidad y colocar tazas o vasos pequeños

DOUBLE FOLDABLE TRAY

Increases capacity by providing extra space for small glasses and cups.

Integración / Integration



LUZ EXTERIOR DE FUNCIONAMIENTO

Al ser un lavavajillas muy silencioso, con la luz encendida sabrá que está trabajando

EXTERIOR ON-OFF BLUE LED LIGHT

As this is an extremely silent product, blue light on the floor indicates if the dishwasher is working.

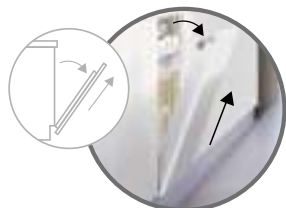

PUERTA DESLIZANTE

Gracias a su sistema de puerta deslizable, el lavavajillas Pando queda perfectamente integrado con el resto de mobiliario.

SLIDING DOOR

Thanks to its sliding door system, Pando Dishwashers perfectly adapt to the rest of the kitchen cabinet.



PANEL DE MANDO INTERIOR

Para mayor integración con el resto del mobiliario, el panel de control se encuentra en la parte superior de la puerta.

INTERIOR TOUCH CONTROL PANEL

The control panel is located at the upper inside of the door to facilitate a perfect integration with your kitchen cabinet.

Programa especial ECO / Special ECO Program



MEJOR LIMPIEZA CON UN MÍNIMO CONSUMO

Avanzada tecnología que mejora el rendimiento de limpieza, reduciendo el consumo tanto de agua como de energía. Todo ello gracias a su programa especial ECO.

IMPROVED CLEANING WHILE REDUCING CONSUMPTION

The special ECO program by **Pando** offers advanced technology that visibly improves the cleaning performance while reducing at the same time both: water and energy consumption.

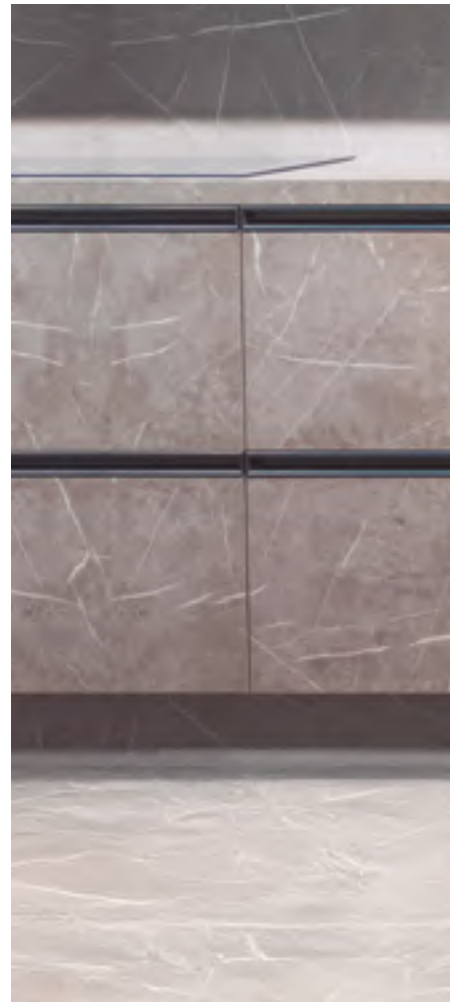

PLT-7461

Ref. 010793

Lavavajillas de integración panelable
Fully-integrated Dishwasher

60 cm

Mueble
Cabinets

8⁽¹⁾

Programas
Programs

16

Servicios
Place settings

3

Brazos pulverizadores
Spray arms



Iluminación LED interior
Interior LED illumination

Prestaciones destacables / Special Features



Programa ECO
ECO Program



Media carga
Half load



Puerta
deslizante
Sliding door



Tercera bandeja
para cubiertos
Third Drawer
for cutlery



Cesta regulable
en altura
Height-
adjustable
upper basket



Luz exterior de
funcionamiento
Exterior operating
light



Lavado
superior
Washing
Upper



Lavado
inferior
Washing
Lower



Lavado
normal
Standard
Washing

Sistema dual de lavado
Dual zone washing system



Características / Features

Capacidad de servicios	Service set capacity	16
Programación diferida	Start delay option	1-24 hrs.
Consumo energético por lavado	Energy consumption per cycle	0,56 kWh
Consumo de agua por lavado	Water consumption per cycle	9 ltrs.
Nivel sonoro	Noise level	43 dB(A)
Iluminación LED interior	Interior LED illumination	Sí / Yes
Panel de control	Control Panel	Touch
AquaStop - Sistema antifugas	AquaStop - Anti-leakage system	Sí / Yes
Guías deslizantes	Sliding guides	Sí / Yes
Descalcificador	Water softener	Sí / Yes
Lavado automático	Automatic washing	Sí / Yes
Peso de la puerta del mueble	Weight of door panel	Min. 5 Kg. / Max. 11 Kg.

(1) Auto | Intensivo | Normal | Eco | Cristalería | 58 min. | Rápido | Auto-limpieza
Auto | Higiene | Normal | Eco | Vidro e cristal | 58 min. | Rápido | Self cleaning



Panel de control / Control Panel: Touch control



Peso puerta del mueble
Weight of door panel
min. 5 kg / max. 11 kg

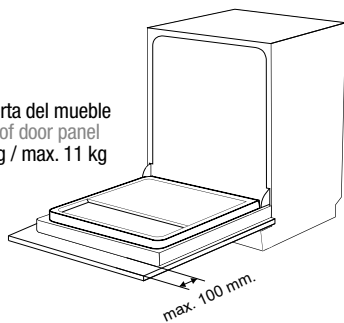

Sistema antibalanceo gracias a sus 4 puntos de sujeción laterales
Anti-balancing system thanks to 4 lateral fixing points



Secado Natural

Al finalizar el ciclo de secado, el lavavajillas abre automáticamente la puerta para favorecer la entrada de aire de forma natural, facilitando la salida del vapor y reduciendo al mínimo el consumo energético en este proceso. El resultado es un excelente secado a coste cero en energía.

Natural Drying

At the end of the drying cycle, the door opens automatically to allow the air flow to enter naturally, making it easier for the steam to escape and minimizing the energy consumption in this process.

The result is an excellent drying at zero energy cost.

PLT-7461

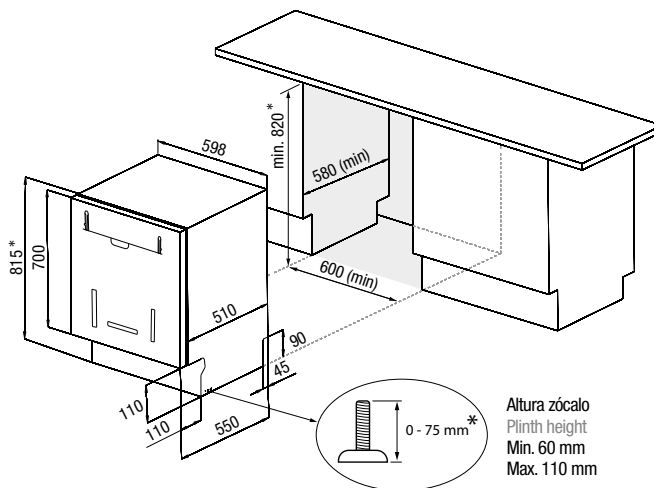

Vista lateral / Side View

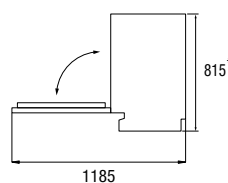

Medidas Panel / Panel Measures

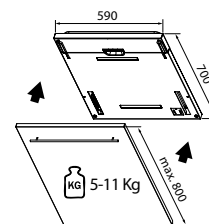

Medidas en / Dimensions in mm



PLT 7462 XXL

Ref. 010794

Lavavajillas de integración panelable
Fully-integrated Dishwasher

60 cm

Mueble
Cabinets

8⁽¹⁾

Programas
Programs

16

Servicios
Place settings

3

Brazos pulverizadores
Spray arms



Permite platos
de gran tamaño
Allows large plates



Altura de la puerta
Door height



Iluminación LED interior
Interior LED illumination

Prestaciones destacables / Special Features



Programa ECO
ECO Program



Media carga
Half load



Puerta
deslizante
Sliding door



Tercera bandeja
para cubiertos
Third Drawer
for cutlery



Cesta regulable
en altura
Height-
adjustable
upper basket



Luz exterior de
funcionamiento
Exterior operating
light



Lavado
superior
Washing
Upper



Lavado
inferior
Washing
Lower



Lavado
normal
Standard
Washing

Sistema dual de lavado
Dual zone washing system



Características / Features

Capacidad de servicios	Service set capacity	16
Programación diferida	Start delay option	1-24 hrs.
Consumo energético por lavado	Energy consumption per cycle	0,56 kWh
Consumo de agua por lavado	Water consumption per cycle	9 ltrs.
Nivel sonoro	Noise level	42 dB(A)
Iluminación LED interior	Interior LED illumination	Sí / Yes
Panel de control	Control Panel	Touch
AquaStop - Sistema antifugas	AquaStop - Anti-leakage system	Sí / Yes
Guías deslizantes		Sí / Yes
Descalcificador		Sí / Yes
Lavado automático		Sí / Yes
Peso de la puerta del mueble	Weight of door panel	Min. 5 Kg. / Max. 11 Kg.

(1) Auto | Intensivo | Normal | Eco | Cristalería | 58 min. | Rápido | Auto-limpieza
Auto | Higiene | Normal | Eco | Vidro e cristal | 58 min. | Rápido | Self cleaning



Panel de control / Control Panel: Touch control



Peso puerta del mueble
Weight of door panel
Min. 5 Kg / Max. 11 Kg

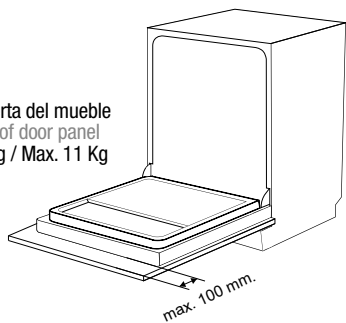

Sistema antibalanceo gracias a sus 4 puntos de sujeción laterales
Anti-balancing system thanks to 4 lateral fixing points



Secado Natural

Al finalizar el ciclo de secado, el lavavajillas abre automáticamente la puerta para favorecer la entrada de aire de forma natural, facilitando la salida del vapor y reduciendo al mínimo el consumo energético en este proceso. El resultado es un excelente secado a coste cero en energía.

Natural Drying

At the end of the drying cycle, the door opens automatically to allow the air flow to enter naturally, making it easier for the steam to escape and minimizing the energy consumption in this process.

The result is an excellent drying at zero energy cost.

PLT-7462 XXL

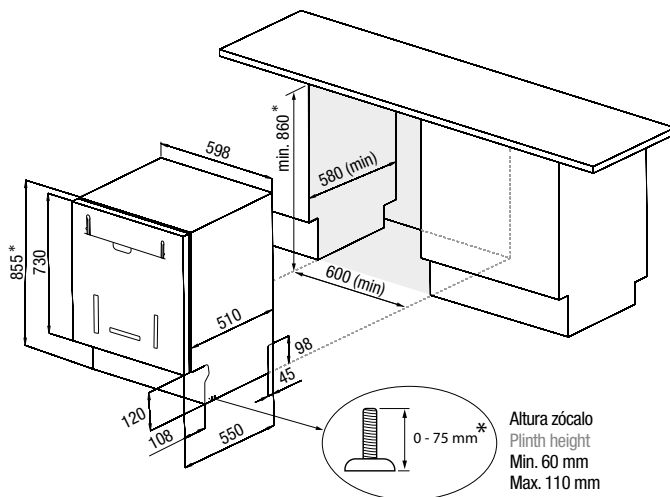

Vista lateral / Side View

Medidas Panel / Panel Measures

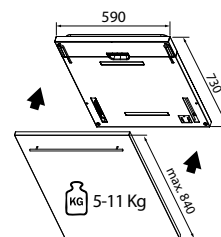
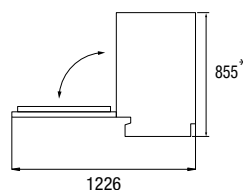

Medidas en / Dimensions in mm



PLB-7161

Lavavajillas de integración panelable Fully-integrated Dishwasher

60 cm

Mueble
Cabinets

7⁽¹⁾

Programas
Programs

14

Servicios
Place settings

2

Brazos pulverizadores
Spray arms

Prestaciones destacables / Special Features



Programa ECO
ECO Program



Media carga
Half load



Puerta
deslizante
Sliding door



Tercera bandeja
para cubiertos
Third Drawer
for cutlery



Cesta regulable
en altura
Height-
adjustable
upper basket



Luz exterior de
funcionamiento
Exterior operating
light



Lavado
superior
Washing
Upper



Lavado
inferior
Washing
Lower



Lavado
normal
Standard
Washing

Sistema dual de lavado
Dual zone washing system



Características / Features

Capacidad de servicios	Service set capacity	14
Programación diferida	Start delay option	1-24 hrs.
Consumo energético por lavado	Energy consumption per cycle	0,95 kWh
Consumo de agua por lavado	Water consumption per cycle	9,9 ltrs.
Nivel sonoro	Noise level	45 dB(A)
Número de temperaturas	Number of temperatures	5
AquaStop - Sistema antifugas	AquaStop - Anti-leakage system	Sí / Yes
Números de brazos pulverizadores	Number of spray arms	2
Peso de la puerta del mueble	Weight of door panel	Min. 4 Kg. / Max. 9 Kg.

(1) Auto | Intensivo | Normal | Eco | Cristalería | 90 min. | Rápido
Auto | Intensive | Normal | Eco | Glass | 90 min. | Quick wash



Panel de control / Control Panel: Touch control



Peso puerta del mueble
Weight of door panel
Min. 4 Kg. / Max. 9 Kg.

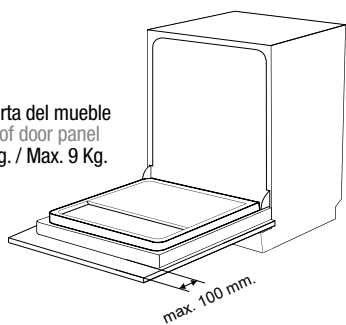

Sistema antibalaceo gracias a sus 4 puntos de sujeción laterales
Anti-balancing system thanks to 4 lateral fixing points



Secado Natural

Al finalizar el ciclo de secado, el lavavajillas abre automáticamente la puerta para favorecer la entrada de aire de forma natural, facilitando la salida del vapor y reduciendo al mínimo el consumo energético en este proceso. El resultado es un excelente secado a coste cero en energía.

Natural Drying

At the end of the drying cycle, the door opens automatically to allow the air flow to enter naturally, making it easier for the steam to escape and minimizing the energy consumption in this process.

The result is an excellent drying at zero energy cost.

PLB-7161

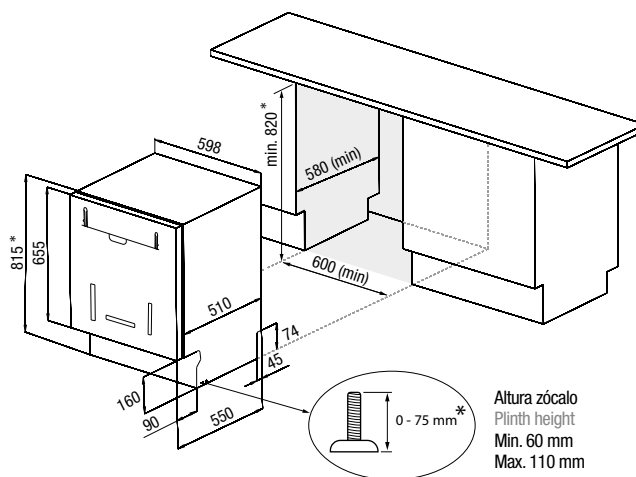

Vista lateral / Side View

Medidas Panel / Panel Mesures

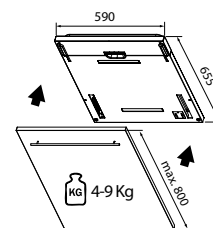
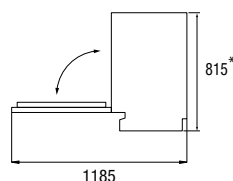

Medidas en / Dimensions in mm



PLB-7146

Lavavajillas de integración panelable Fully-integrated Dishwasher

45 cm

Mueble
Cabinets

7⁽¹⁾

Programas
Programs

10

Servicios
Place settings

2

Brazos pulverizadores
Spray arms

Prestaciones destacables / Special Features



Programa ECO
ECO Program



Media carga
Half load



Puerta
deslizante
Sliding door



Tercera bandeja
para cubiertos
Third Drawer
for cutlery



Cesta regulable
en altura
Height-
adjustable
upper basket



Luz exterior de
funcionamiento
Exterior operating
light



Lavado
superior
Washing
Upper



Lavado
inferior
Washing
Lower



Lavado
normal
Standard
Washing

Sistema dual de lavado
Dual zone washing system



Características / Features

Capacidad de servicios	Service set capacity	10
Programación diferida	Start delay option	1-24 hrs.
Consumo energético por lavado	Energy consumption per cycle	0,75 kWh
Consumo de agua por lavado	Water consumption per cycle	8 ltrs.
Nivel sonoro	Noise level	45 dB(A)
Número de temperaturas	Number of temperatures	5
AquaStop - Sistema antifugas	AquaStop - Anti-leakage system	Sí / Yes
Números de brazos pulverizadores	Number of spray arms	2
Peso de la puerta del mueble	Weight of door panel	Min. 4 Kg. / Max. 8 Kg.

(1) Auto | Intensivo | Normal | Eco | Cristalería | 90 min. | Rápido
Auto | Higiene | Normal | Eco | Vidro e cristal | 90 min. | Rápido



Panel de control / Control Panel: Touch control



Peso puerta del mueble
Weight of door panel
Min. 4 Kg. / Max. 8 Kg.

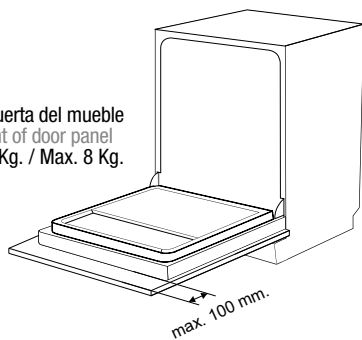

Secado Natural

Al finalizar el ciclo de secado, el lavavajillas abre automáticamente la puerta para favorecer la entrada de aire de forma natural, facilitando la salida del vapor y reduciendo al mínimo el consumo energético en este proceso. El resultado es un excelente secado a coste cero en energía.

Natural Drying

At the end of the drying cycle, the door opens automatically to allow the air flow to enter naturally, making it easier for the steam to escape and minimizing the energy consumption in this process. The result is an excellent drying at zero energy cost.

PLB-7146

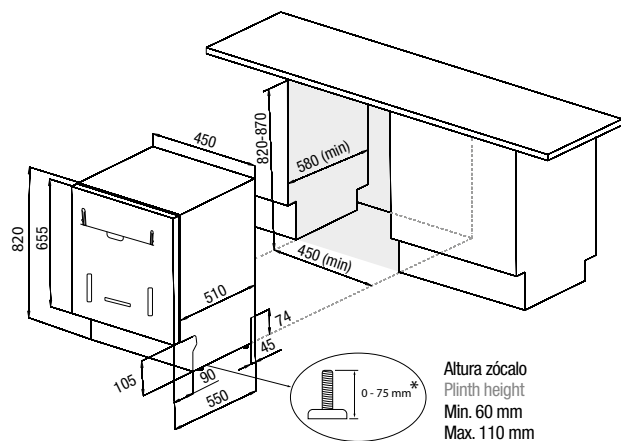

Vista lateral / Side View

Medidas Panel / Panel Measures

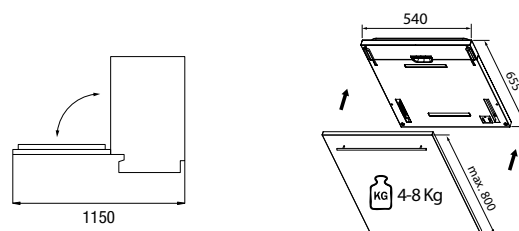

Medidas en / Dimensions in mm

Lavadoras y secadoras

Pando Integral Cooking presenta su séptima gama; las lavadoras y secadoras, fusionando tecnología avanzada, diseño de vanguardia y eficiencia energética. Disponible en versiones de libre instalación e integración a mueble, garantiza rendimiento superior, así como un mínimo consumo de agua y energía. Con un diseño elegante y funciones inteligentes, optimiza cada ciclo para resultados impecables.

Washing machines and Dryers

Pando Integral Cooking presents its seventh range; the washers and dryers, merging advanced technology, cutting-edge design, and energy efficiency. Available in freestanding and built-in versions, it guarantees superior performance, as well as minimal water and energy consumption. With an elegant design and smart functions, it optimizes each cycle for impeccable results.



Lavadoras y secadoras
Washing machine



PWL-9160
Lavadora
de integración Panelable
Washing Machine
Integrated Panel Door
60 cm - 8 Kg
p. 262



PWLS-9161
Lavadora-Secadora
de integración Panelable
Washer-Dryer
Integrated Panel
60 cm - 8 Kg / 5 Kg
p. 264



PWL-8160
Lavadora
de libre instalación
Washing Machine
Freestanding
60 cm - 8 Kg
p. 266



PWS-8161
Secadora
de libre instalación
Dryer
Freestanding
60 cm - 8 Kg
p. 268

Descubre el futuro del lavado
con **Pando**

Discover the future of laundry
with **Pando**



Pure Care

Elimina hasta el 99,9 % de alérgenos y bacterias.
Con altas temperaturas, brindando una limpieza profunda y segura. Ideal para personas con piel sensible o alergias.

It eliminates up to 99.9% of allergens and bacteria
with high temperatures, providing a deep and safe clean. Ideal for people with sensitive skin or allergies.



Eco Longlife Motor

Motor de alta eficiencia, fiabilidad y ultra silencioso
La avanzada tecnología del motor ofrece alta eficiencia, fiabilidad y funcionamiento ultra silencioso. Su diseño minimiza el desgaste, prolongando la vida útil y optimizando el rendimiento. Cuenta con una garantía de 10 años para el motor.

High-efficiency, reliable, and ultra-quiet motor.
The advanced engine technology offers high efficiency, reliability and ultra-quiet operation. Its design minimises wear and tear, prolonging service life and optimising performance.

*Nota: No todas nuestras lavadoras y secadoras incorporan todas estas características
Note: Not all of our washing machines/dryers include all of these features.*



Aquastop

Previene fugas de la lavadora

Detiene automáticamente la entrada de agua ante fallos en la tubería o manguera, evitando inundaciones.

Prevents washing machine leaks

Automatically stops the water supply in case of pipe or hose failures, preventing flooding.



Multi Jet

Mejora el lavado en solo 12 minutos

Inyecta agua con detergente directamente en la ropa, mejorando el lavado en solo 12 minutos. Su sistema de recirculación ahorra energía y agua, optimizando la limpieza.

Improving the wash in just 12 minutes

It injects water with detergent directly into the clothes, improving the wash in just 12 minutes. Its recirculation system saves energy and water, optimising cleaning.



Ultra Dry

Dos programas de secado rápido

Diseñados para secar la ropa de manera eficiente en menos tiempo. Camisas 20' seca las camisas en 20 minutos y el Express 34' en 34 minutos, proporcionando un secado eficiente y rápido para diferentes tipos de prendas.

Two quick drying programs

Designed to dry clothes efficiently in less time. The 20' Shirts program dries shirts in 20 minutes, and the Express 34' dries in 34 minutes, providing efficient and fast drying for different types of garments.



Aquaball

Evita el desperdicio de detergente

Válvula especial que evita el desperdicio de detergente, manteniéndolo en la cuba. Esto reduce costos de lavado y mejora la eficiencia.

Prevents the waste of detergent

Special valve that prevents the waste of detergent, keeping it in the drum. This reduces washing costs and improves efficiency.



Steam Care

Vapor que reduce arrugas

Esta tecnología utiliza vapor a alta temperatura para reducir arrugas y mejorar la higiene. Al final del ciclo, una sesión de vapor optimiza los resultados en 26 minutos.

Steam to reduce creases

The technology uses high-temperature steam to reduce creases and improve hygiene. At the end of the cycle, a steam session optimises the results in 26 minutes.



Anti-crease Program

Programa antiarrugas

Las soluciones antiarrugas incluyen un tambor perlado, un sistema de elevación y mecanismos exclusivos para un secado delicado y uniforme, reduciendo las arrugas y cuidando las prendas al final del ciclo.

Anti-crease Program

The Anti-crease Program includes a pearlised drum, a lifting system and exclusive mechanisms for delicate and uniform drying, reducing creases and taking care of clothes at the end of the cycle.



Eco-logic

Ajusta energía, agua y tiempo en media carga

Eco-Logic System ajusta automáticamente energía, agua y tiempo en media carga, reduciendo hasta un 50% el consumo y optimizando los recursos.

Adjusts energy, water and time in half-load mode

Eco-Logic System automatically adjusts energy, water and time in half-load mode, reducing consumption by up to 50% and optimising resources.



Spillover Safety

Sistema de seguridad automático de desagüe

Mediante un sensor de presión (EPS) que mide el nivel de agua, previene desbordamientos. Si los niveles son altos, se activa automáticamente la bomba de desagüe para evitar riesgos.

Automatic drainage safety system

Using a pressure sensor (EPS) that measures the water level, it prevents overflow. If the levels are high, the drainage pump is automatically activated to avoid risks.



Bloqueo para niños / Child lock

Bloquea el panel de control de mandos

La función de bloqueo para niños impide que se modifique el ciclo de lavado al tocar los mandos. Al activarla, los botones del panel de control quedan bloqueados, evitando cambios accidentales.

Locked de control panel buttons

The child lock function prevents the washing cycle from being modified by touching the controls. When activated, the control panel buttons are locked, preventing accidental changes.

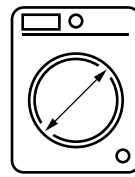

Ø47 cm



PWL-9160

Ref. 010867

Lavadora de integración Panelable - Inox
Washing Machine Integrated Panel Door - Stainless Steel

60 cm

Mueble
Cabinets

8 kg

Capacidad
Capacity

15

Programas
Programs

10

Funciones
Functions

Pando

10 AÑOS

GARANTIA

Exclusiva para motores
Exclusive for motors



Programas / Programs

Eco 40-60 | Algodón | Algodón prelavado | Algodón 20°C | Colores | Lana | Aclarar | Allergy care
Centrifugado/Drenaje | Lavado a mano/Delicado | Sintéticos | Edredón | Vaqueros | Rápido 12 min. | Rápido 60 min. 60°C

Eco 40-60 | Cotton | Cotton pre-wash | Cotton 20° | Colours | Wool | Rinse | Allergy care | Spin/Drain
Hand wash/Delicate | Synthetics | Duvet | Jeans | Rapid 12 min. | Fast 60 min. 60°C

Características / Features

Capacidad (kg)	Capacity (kg)	8
Volumen (L)	Voluma (L)	51
Programas	Programmes	15
Programa ECO	Program ECO	Sí / Yes
Consumo energético por ciclo	Energy consumption per cycle	0,47 kWh
Nivel sonoro	Noise level	46dB(A)
Centrifugado (rpm)	Centrifuged (rpm)	1400
Ø Puerta (cm)	Ø Door (cm)	47
Display	Display	Touch



PWL-9160

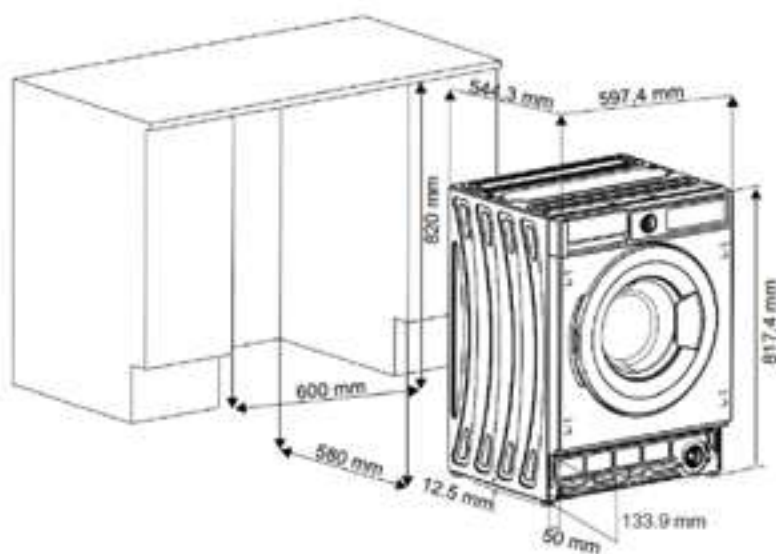

Notas / Notes

Posibilidad de cambiar el sentido de apertura de la puerta panelable del mueble
 Option to change the opening direction of the panelable door of the cabinet

Medidas en / Dimensions in mm

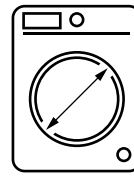

Ø47 cm



PWLS-9161

Ref. 010868

Lavadora-Secadora de integración Panelable - Inox
Washer-Dryer Integrated Panel Door - Stainless Steel

60 cm

Mueble
Cabinets

8 kg

Capacidad Lavadora
Capacity

5 kg

Capacidad Secadora
Capacity

15

Programas
Programs

10

Funciones
Functions

Pando
10 AÑOS
GARANTIA

Exclusiva para motores
Exclusive for motors

Programas / Programs

Eco 40-60 | Algodón | Algodón 20° | Sintético | Lana y seda | Edredón | Aclarado | Allergy care | Centrifugado/Drenaje
Rápido 15 min. | Rápido 60 min. 60° | Secado suave | Secado algodón | Lavado y secado rápido | Lavado y secado de algodón

Eco 40-60 | Cotton | Cotton 20° | Synthetics | Wool & Silk | Duvet | Rinse | Allergy care | Spin/Drain | Rapid 15 min.
Fast 60° 60°C | Gentle Dry | Cotton Dry | Quick Wash & Dry | Cotton Wash & Dry

Lavadora



Secadora



Características / Features

Capacidad lavadora (kg)	Washing capacity (kg)	8
Capacidad secadora (kg)	Dryer capacity (kg)	5
Volumen (L)	Voluma (L)	51
Programas lavadora	Washing programmes	15
Programas secadora	Dryer programmes	3
Programa ECO	Program ECO	Sí / Yes
Consumo energético por ciclo (Lavado)	Energy consumption per cycle (Washing)	0,47 kWh
Consumo energético por ciclo (Secado)	Energy consumption per cycle (Drying)	2,67 kWh
Nivel sonoro Lavadora	Washing noise level	53dB(A)
Nivel sonoro Secadora	Dryer noise level	64dB(A)
Centrifugado (rpm)	Centrifuged (rpm)	1400
Tipo de secado Condensación	Drying type Condensation	Sí / Yes
Ø Puerta (cm)	Ø Door (cm)	47
Display	Display	Touch



PWLS-9161

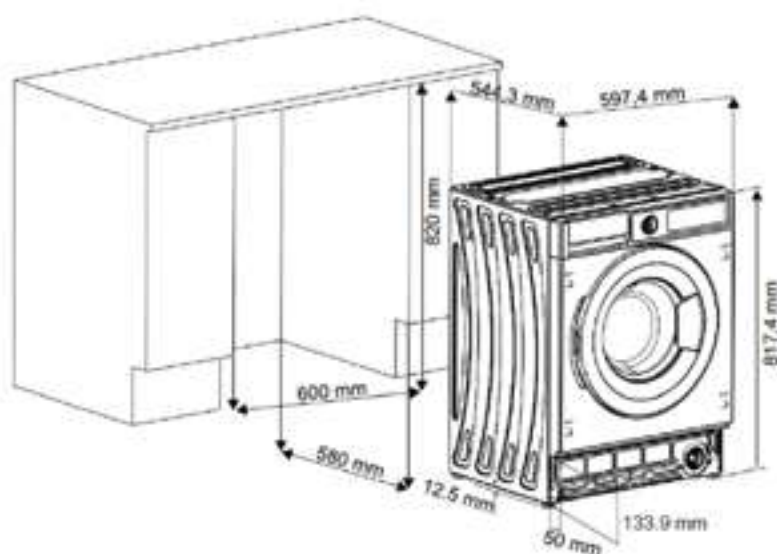

Notas / Notes

Posibilidad de cambiar el sentido de apertura de la puerta panelable del mueble
 Option to change the opening direction of the panelable door of the cabinet

Medidas en / Dimensions in mm

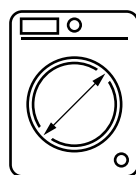

Ø51 cm



PWL-8160

Ref. 010865

Lavadora de libre instalación - Blanca
Freestanding washing machine - White

60 cm

Mueble
Cabinets

8 kg

Capacidad
Capacity

16

Programas
Programs

10

Funciones
Functions

Pando

10 AÑOS

GARANTIA

Exclusiva para motores
Exclusive for motors



-20%

Programas / Programs

Eco 40-60 | Algodón | Algodón prelavado | Algodón 20°C | Colores | Lana | Aclarar | Pure care | Centrifugado/Drenaje
Lavado a mano/Delicado | Sintéticos | Edredón | Tejanos | Rápido 12 min. | Rápido 15 min. | Rápido 60 min. 60°C

Eco 40-60 | Cotton | Cotton pre-wash | Cotton 20° | Colours | Wool | Rinse | Pure care | Spin/Drain Hand wash
Delicate | Synthetics | Duvet | Jeans | Rapid 12 min. | Rapid 15 min. | Fast 60 min. 60°C

Características / Features

Capacidad lavadora (kg)	Capacity (kg)	8
Volumen (L)	Voluma (L)	55
Programas	Programmes	16
Programa ECO	Program ECO	Sí / Yes
Consumo energético por ciclo	Energy consumption per cycle	0,47 kWh
Nivel sonoro	Noise level	64dB(A)
Centrifugado (rpm)	Centrifuged (rpm)	1400
Ø Puerta (cm)	Ø Door (cm)	51
Display	Display	Touch



Accesorio para montaje en columna de una secadora y una lavadora.
Accessory for column installation of a dryer and a washing machine

Kit Unión Lavadora-Secadora
Washer-Dryer Connection Kit
Ref. 010881



Kit Unión Lavadora-Secadora con mesa extraíble
Washing machine-dryer connection kit with pull-out table
Ref. 010882



PWL-8160

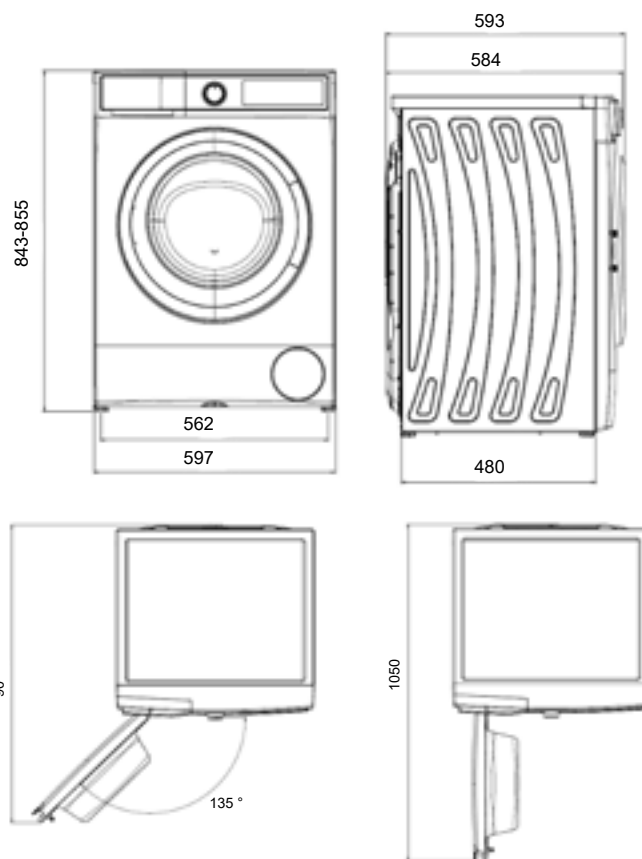

Medidas en / Dimensions in mm

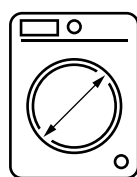

Ø51 cm

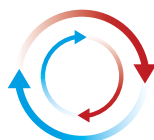

Tipo de secado
Bomba de Calor
Drying Type
Heat pump



PWS-8161

Ref. 010866

Secadora de libre instalación - Blanca
Freestanding Dryer - White

60 cm

Mueble
Cabinets

8 kg

Capacidad
Capacity

15

Programas
Programs



Tambor con doble Giro
Drum with double turn

Pando

10 AÑOS

GARANTIA

Exclusiva para motores
Exclusive for motors



Programas / Programs

Algodón Extra Seco | Algodón ecológico | Algodón Planchado en seco | Sintéticos Armario Seco | Sintéticos Planchado en seco
Delicado | Mezclado | Cuidado del bebé | Toallas | Higiénico | Ultra Dry | Programa Antiarrugas | Edredón | Lana

Cotton Extra Dry | Organic Cotton | Cotton Dry Cleaner | Synthetics Dry Wardrobe | Synthetics Dry Cleaner | Synthetics Dry
Ironing | Delicate | Blended | Baby Care | Towels | Hygienic | Ultra Dry | Anti-Crease Program | Duvet | Wool | Wool

Características / Features

Capacidad (kg)	Capacity (kg)	8
Volumen (L)	Voluma (L)	112
Programas	Programmes	15
Programa ECO	Program ECO	Sí / Yes
Nivel sonoro	Noise level	64dB(A)
Consumo energético por ciclo	Energy consumption per cycle	1,02 kWh
Acabado tambor interior	Finishing inside drum	INOX
Tipo de secado Bomba de calor	Drying Type Heat pump	Sí / Yes
Ø Puerta (cm)	Ø Door (cm)	51
Display	Display	Touch
Iluminación interior	Interior lighting	Sí / Yes



Accesorio para montaje en columna de una secadora y una lavadora.
Accessory for column installation of a dryer and a washing machine

Kit Unión Lavadora-Secadora
Washer-Dryer Connection Kit
Ref. 010881



Kit Unión Lavadora-Secadora con mesa extraíble
Washing machine-dryer connection kit with pull-out table
Ref. 010882



PWS-8161

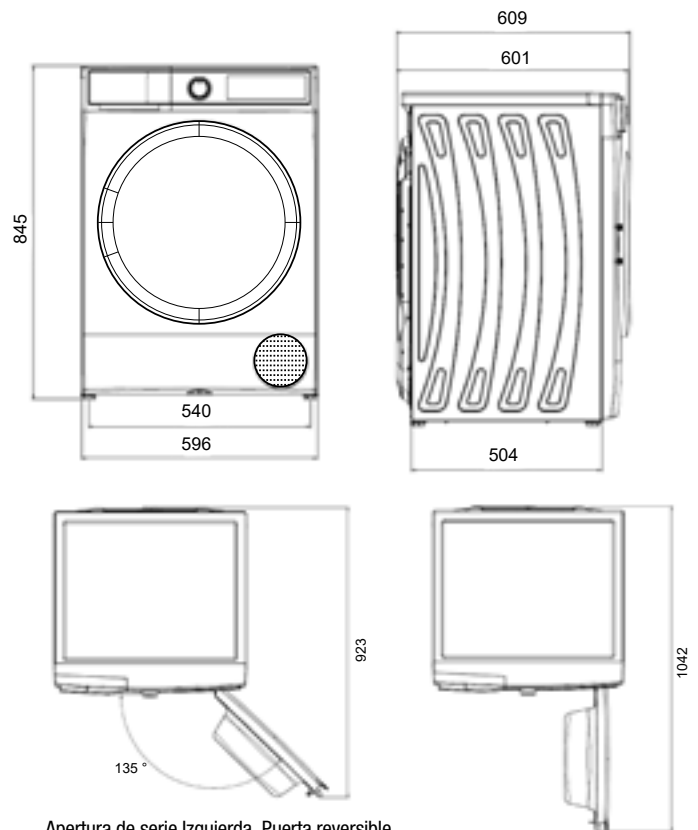

Apertura de serie Izquierda. Puerta reversible
Standard opening Left. Reversible door

Medidas en / Dimensions in mm

Frigoríficos

Máximas prestaciones y tecnología de vanguardia.

Fabricados con la Personalidad y el Diseño **Pando**

Refrigerators

maximum performance and state-of-the-art technology

Made with **Pando** Personality and Design







PFBE CONG
Ref. 010665

Congelador de integración panelable bajo encimera
Built-in freezer for overlay decor panel
82 x 59 cm - 83 L
p. 276

Frigoríficos COMBI de integración panelable
Built-in COMBI refrigerators for overlay decor panel
177 x 54 cm - 243 L
p. 278-280

PFBI FRIGO
Ref. 010336

Frigorífico de integración panelable
Built-in refrigerator for overlay decor panel
177 x 54 cm - 294 L
p. 282

PFBI CONG
Ref. 010337

Congelador de integración panelable
Built-in freezer for overlay decor panel
177 x 54 cm - 197 L
p. 284

PFBI L COMBI
Ref. 010523

Frigorífico COMBI L de integración panelable
Built-in refrigerator COMBI L for overlay decor panel
194 x 54 cm - 267 L
p. 286

Frigoríficos

Pando presenta la gama completa de frigoríficos y congeladores con las máximas prestaciones y tecnología de vanguardia.

La gama de frío de **Pando**, ha sido especialmente diseñada para complementar nuestro ya extenso portfolio de productos, ofreciendo al cliente una solución completa e integral de productos **Pando** para su proyecto de cocina.

Refrigerators

Pando presents a complete range of refrigerators and freezers with the highest performance and cutting-edge technology.

The **Pando** refrigeration range has been specially designed to complement our already extensive product portfolio, offering the customer a complete and integral solution of **Pando** products for their kitchen project.



PFBI XL COMBI Ref. 010522

Frigorífico COMBI XL de integración panelable
Built-in COMBI XL for overlay decor panel
194 x 69 cm - 341 L
p. 288

PFBI XL FRIGO Ref. 010681

Frigorífico XL de integración panelable
Built-in refrigerator XL for overlay decor panel
194 x 69 cm - 335 L
p. 290

PFLC COMBI Ref. 010338 Cristal negro

Frigorífico COMBI libre instalación.
Refrigerator COMBI Freestanding. Black glass
201 x 59 cm - 367 L
p. 292

Frigorífico COMBI Americano libre instalación 4 Puertas
American COMBI refrigerator Freestanding 4 Doors
190 x 90 x 60 cm - 503 L
p. 294

Frigorífico COMBI Americano XL libre instalación 4 Puertas
American COMBI refrigerator XL Freestanding 4 Doors
190 x 91 x 69 cm - 600 L
p. 296

**Tecnología *Pando*
para una perfecta conservación**

***Pando* Technology
for a perfect conservation**



**Óptima
conservación
de los alimentos**
**Optimal
conservation
of food**

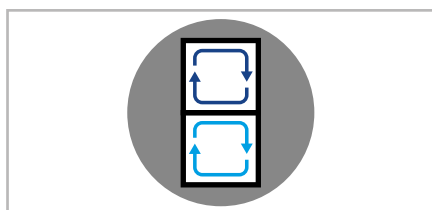

Doble Sistema de Refrigeración

Natural Flow Cooling by Pando, incorporado a nuestros frigoríficos que, mediante la inyección de aire frío, mantiene una temperatura constante y más eficiente y sin reseca los alimentos. NO-Frost, sistema anti-escarcha que incorporan nuestros congeladores.

Dual Cooling System

Natural Flow Cooling by Pando, incorporated into our refrigerators which, by injecting cold air, maintains a constant temperature in a very efficient way, and without drying out food. NO-Frost, anti-frost system that all our freezers incorporate.



Bisagra Profesional Puerta Fija

Los frigoríficos panelables incorporan una bisagra profesional de gran resistencia, que se coloca directamente a Puerta Fija y soporta una puerta panelable de hasta 50 Kg.

Professional hinge “Door-on-Door”

Built-in refrigerators come with a professional hinge of great resistance, which is placed directly onto a Fixed Door and supports an overlay panel door of up to 50 Kg.



Sistema Puerta Deslizante

En el sistema de puerta deslizante, el panel se fija al armario con bisagras y se une al frigorífico mediante guías adicionales, permitiendo un deslizamiento suave al abrir y cerrar.

Sliding Door System

In the sliding door system, the panel is fixed to the cabinet with hinges and attached to the refrigerator by means of additional guides, allowing soft sliding when opening and closing.

Nota: No todos nuestros frigoríficos incorporan estas 12 características
Note: Not all our refrigerator models have all 12 features.



Inverter Compressor Technology

Compresores de última generación con tecnología Inverter que aceleran el proceso de refrigeración, reduciendo el tiempo de enfriamiento, minimizando emisión de ruidos y consumo energético

State-of-the-art compressors with inverter technology reduce the time needed to cool down the interior, and minimize noise emission and energy consumption.



Pure Beam+

Aplicando un sistema de radiación ultravioleta UV-C con luces LED en combinación con un filtro de carbón, establece una solución desinfectante que no solo es eficaz contra malos olores, sino también elimina bacterias y virus en el aire.

Applying a system of UV-C ultraviolet radiation with LED lights in combination with a carbon filter, creates a disinfectant environment that is effective against bad odors, but also eliminates bacteria and viruses floating in the air.

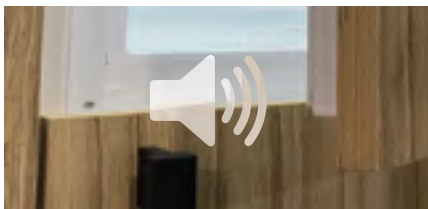

Alarma Puerta abierta

Señal acústica que avisa si la puerta se ha quedado abierta o no se ha cerrado correctamente. Así nos aseguramos el buen funcionamiento del aparato evitando pérdidas de frío y un consumo energético innecesario.

Open Door alarm

Acoustic warning signal that, if the door is open, or not properly closed, for a period of time, ensures proper functioning of the refrigerator, and avoids excessive losses of cold air, as well as a higher energy consumption than necessary.



UltraFresh Technology

Elimina el gas etileno, que emiten los alimentos frescos de forma natural al madurarse dentro del cajón de verduras. Esto mejora la conservación de los alimentos, especialmente de las frutas y verduras, manteniéndolos en estado fresco durante más tiempo.

Removes ethylene gas, a gas which is naturally emitted by fresh food when riping in the vegetable drawer. This maximizes the conservation of fresh food, especially fruits and vegetables, keeping them fresh for longer.



Cold Air Station by Pando

Sistema innovador de refrigeración mediante ventiladores que garantiza un reparto óptimo y una circulación constante del aire frío dentro del frigorífico y así evita condensación y escarcha.

Innovative Pando cooling system using several fans, which ensures an optimal distribution and constant circulation of cold air inside the refrigerator and thus avoids condensation and frost.



Iluminación interior LED

La iluminación interna es mediante tecnología LED, lo que significa una mayor capacidad lumínica con un muy reducido consumo energético.

Interior LED light illumination

The internal lighting is fully based on LED technology, which means more light and a very low energy consumption.



Humidity Control

El cajón de verduras y/o la Zona Cero incorpora un controlador que permite regular el nivel de humedad en el interior del cajón.

The vegetable drawer and/or Zero Degree Zone incorporate a controller that allows to regulate the humidity level inside the drawer.



Metal Cooling

Accesorio metálico situado en la pared interior trasera del frigorífico, que mantiene y conserva el frío dentro del refrigerador mientras que se realiza un uso frecuente, como la apertura o cierre de la puerta.

Metal accessory placed on the inside rear wall of the refrigerator, which keeps and maintains the cold inside the refrigerator during frequent use, such as opening or closing the door.



Control electrónico Touch Control

Display moderno con tecnología Touch Control de fácil manejo y muy visual. Ubicado en el interior de cada modelo (excepto modelo Americano)

Electronic Touch Control Panel

Modern display with Touch Control technology that is easy to use and very visual, placed in the interior of the product (except American refrigerator).



PFBE CONG 82 X 59

Ref. 010665

Congelador de integración panelable bajo encimera
Built-in freezer for overlay decor panel



83 L
Capacidad
Capacity



Bisagra profesional.
Puerta Fija
Professional hinge.
"Door-on-Door"



83 L
NO Frost
Technology



Características / Features

Dimensiones producto (AlxAnxF)	Product size (HxWxD)	820/870 x 596 x 550 mm
Total Volumen	Total Volume	83 L
Temperatura de ajuste	Temperature setting	-16 / -24 °C
Consumo de energía	Energy Consumption	151 kWh/año-year
Nivel de ruido acústico	Noise level	38 dBA
Bisagra Fija profesional	Professional hinge. "Door-on-Door"	Si / Yes
Clase Climática	Climate Class	SubTropical
Panel de control	Control panel	Electronic
Super congelación	Super Freezer	Si / Yes
Peso máximo puerta panelable	Maximum weight of panel door	45 Kg



PFBE CONG 82 X 59

Ref. 010665



Condensador Trasero = Laterales Frios
Rear Condenser Coil = Cold Sides

Apertura de serie Izquierda
Puerta reversible
Standard opening Left
Reversible door

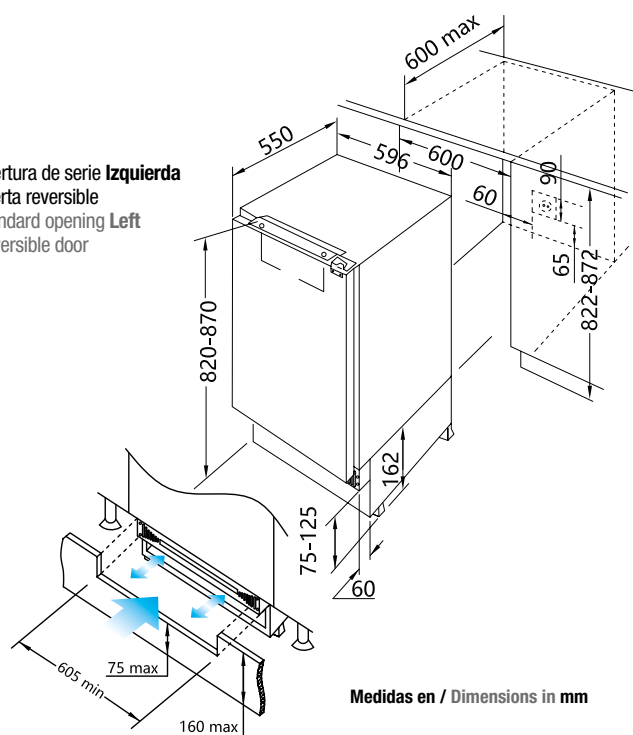

Medidas en / Dimensions in mm



PFBI COMBI

Ref. 010334

PUERTA DESLIZANTE SLIDING DOOR

Frigorífico COMBI de integración panelable
Built-in refrigerator COMBI for overlay decor panel

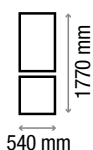

243 L
Capacidad
Capacity



UltraFresh
Technology



Sistema Sliding Door
Sliding Door System



180 L
Natural
Flow Cooling

63 L
NO Frost
Technology



Características / Features

Dimensiones producto (AlxAxAnxF)	Product size (HxWxD)	1770x540x545 mm
Total Volumen	Total Volume	243 L
Capacidad Frigorífico	Refrigerator Volume	180 L
Capacidad Congelador	Freezer Volume	63 L
Consumo de energía	Energy Consumption	218 kWh/año-year
Nivel de ruido acústico	Noise level	41 dBA
Iluminación interior LED	Interior LED Lighting	Sí / Yes
Clase Climática	Climate Class	Tropical
Peso máximo puerta panelable	Maximum weight of panel door	50 Kg

FUNCIONES: Modo vacaciones | Modo ECO | Modo Rápido | Modo Demo



Condensador Trasero = Laterales Fríos
Rear Condenser Coil = Cold Sides

PUERTA DESLIZANTE PFBI COMBI SLIDING DOOR

Ref. 010334

Composición/ Composition: Side by Side

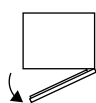

Apertura de serie Derecha
Puerta reversible
Standard opening Right
Reversible door

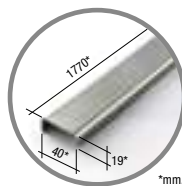

Opcional / Optional
Ref. 010463
Perfil de unión Inox
Stainless Steel + connecting profile

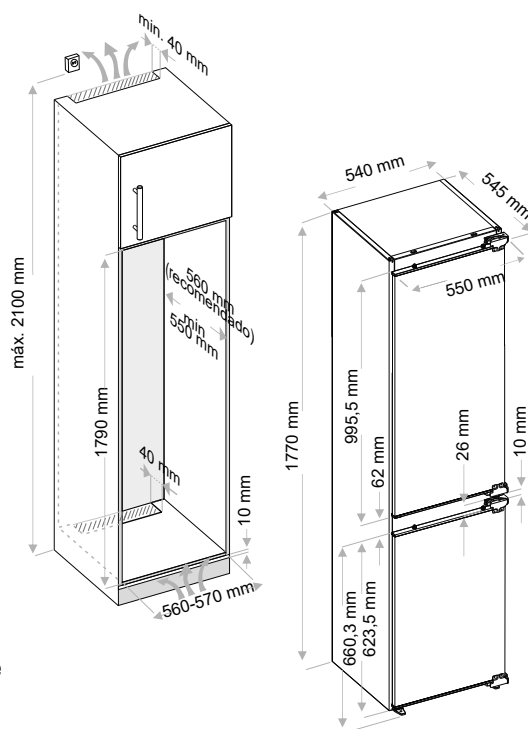

Medidas en / Dimensions in mm

PFBI COMBI + PFBI COMBI
Ref. 010334 Ref. 010334



PFBI COMBI

Ref. 010335

**PUERTA FIJA
DOOR-ON-DOOR**

Frigorífico COMBI de integración panelable
Built-in refrigerator COMBI for overlay decor panel

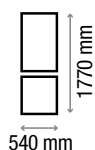

243 L
Capacidad
Capacity



**UltraFresh
Technology**

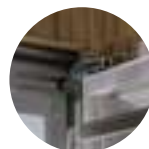

Bisagra profesional.
Puerta Fija
Professional hinge.
"Door-on-Door"



180 L
Natural
Flow Cooling

63 L
NO Frost
Technology



Características / Features

Dimensiones producto (AlxAnxF)	Product size (HxWxD)	1770x540x545 mm
Total Volumen	Total Volume	243 L
Capacidad Frigorífico	Refrigerator Volume	180 L
Capacidad Congelador	Freezer Volume	63 L
Consumo de energía	Energy Consumption	218 kWh/año-year
Nivel de ruido acústico	Noise level	41 dBA
Iluminación interior LED	Interior LED Lighting	Sí / Yes
Clase Climática	Climate Class	Tropical
Peso máximo puerta panelable	Maximum weight of panel door	50 Kg

FUNCIONES: Modo vacaciones | Modo ECO | Modo Rápido | Modo Demo



Condensador Trasero = Laterales Fríos
Rear Condenser Coil = Cold Sides

PUERTA FIJA
DOOR-ON-DOOR

PFBI COMBI
Ref. 010335

Composición/ Composition: Side by Side



Apertura de serie **Derecha**
Puerta reversible
Standard opening **Right**
Reversible door

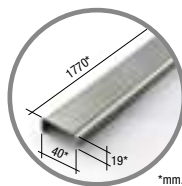

Opcional / Optional
Ref. 010463
Perfil de unión Inox
Stainless Steel + connecting profile

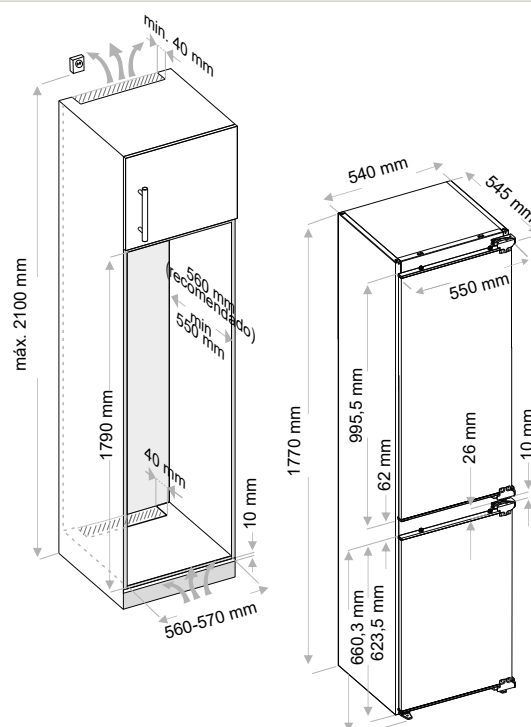

Medidas en / Dimensions in mm

PFBI COMBI + **PFBI COMBI**
Ref. 010335 Ref. 010335



PFBI FRIGO

Ref. 010336

Frigorífico de integración panelable
Built-in refrigerator for overlay decor panel

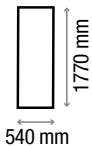

294 L
Capacidad
Capacity



UltraFresh
Technology

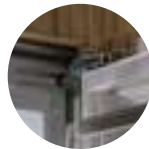

Bisagra profesional.
Puerta Fija
Professional hinge.
"Door-on-Door"



294 L
Natural
Flow Cooling



Características / Features

Dimensiones producto (AlxAnxF)	Product size (HxWxD)	1770x540x545 mm
Total Volumen	Total Volume	294 L
Capacidad Frigorífico	Refrigerator Volume	294 L
Consumo de energía	Energy Consumption	112 kWh/año-year
Nivel de ruido acústico	Noise level	39 dBA
Iluminación interior LED	Interior LED Lighting	Sí / Yes
Clase Climática	Climate Class	Subtropical
Peso máximo puerta panelable	Maximum weight of panel door	50 Kg

FUNCIONES: Modo vacaciones | Modo ECO | Modo Rápido | Modo Demo



Condensador Trasero = Laterales Fríos
Rear Condenser Coil = Cold Sides

PFBI FRIGO

Ref. 010336

Composición / Composition: Side by Side

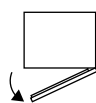

Apertura de serie **Derecha**
Puerta reversible
Standard opening **Right**
Reversible door

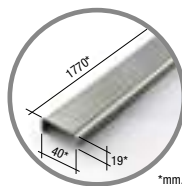

Opcional / Optional
Ref. 010463
Perfil de unión Inox
Stainless Steel + connecting profile

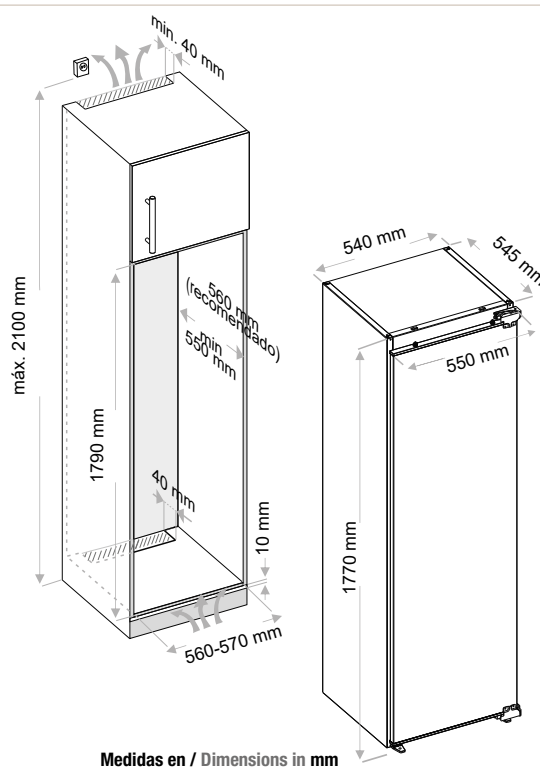

Medidas en / Dimensions in mm

PFBI CONG + **PFBI FRIGO**
Ref. 010337 Ref. 010336



PFBI CONG

Ref. 010337

Congelador de integración panelable
Built-in freezer for overlay decor panel

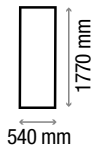

197 L
Capacidad
Capacity



Bisagra profesional.
Puerta Fija
Professional hinge.
"Door-on-Door"



197 L
NO Frost
Technology



Características / Features

Dimensiones producto (AlxAnxF)	Product size (HxWxD)	1770x540x545 mm
Total Volumen	Total Volume	197 L
Capacidad Congelador	Freezer Volume	197 L
Consumo de energía	Energy Consumption	231 kWh/año-year
Nivel de ruido acústico	Noise level	40 dBA
Iluminación interior LED	Interior LED Lighting	Sí / Yes
Clase Climática	Climate Class	Tropical
Peso máximo puerta panelable	Maximum weight of panel door	50 Kg

FUNCIONES: Modo vacaciones | Modo ECO | Modo Rápido | Modo Demo



Condensador Trasero = Laterales Fríos
Rear Condenser Coil = Cold Sides

PFBI CONG

Ref. 010337

Composición/ Composition: Side by Side

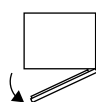

Apertura de serie **Derecha**
Puerta reversible
Standard opening **Right**
Reversible door

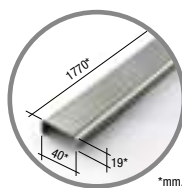

Opcional / Optional
Ref. 010463
Perfil de unión Inox
Stainless Steel + connecting profile

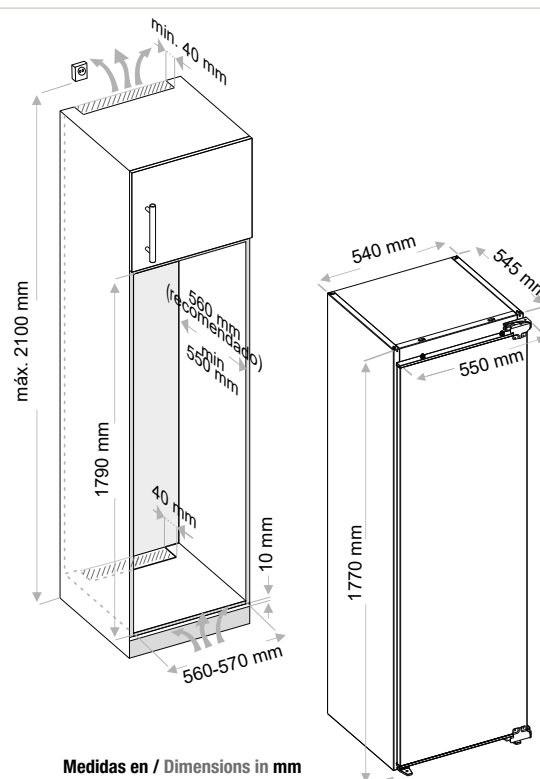

Medidas en / Dimensions in mm

PFBI CONG
Ref. 010337



PFBI FRIGO
Ref. 010336



PFBI L COMBI

Ref. 010523

Frigorífico COMBI de integración panelable 194 x 54
Built-in refrigerator COMBI for overlay decor panel 194 x 54

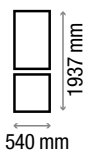

267 L
Capacidad
Capacity



UltraFresh
Technology

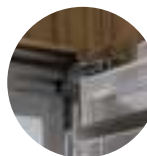

Bisagra profesional.
Puerta Fija
Professional hinge.
"Door-on-Door"



Iluminación LED
pared trasera
Back wall with LED
backlight



200 L
NO Frost
Technology

67 L
NO Frost
Technology



Características / Features

Dimensiones producto (AlxAnxF)	Product size (HxWxD)	1937x540x550
Total Volumen	Total Volume	267 L
Capacidad Frigorífico	Refrigerator Volume	200 L
Capacidad Congelador	Freezer Volume	67 L
Consumo de energía	Energy Consumption	232 kWh/año-year
Nivel de ruido acústico	Noise level	41 dBA
Iluminación interior LED	Interior LED Lighting	Sí / Yes
Clase Climática	Climate Class	Subtropical
Peso máximo puerta panelable	Maximum weight of panel door	30 Kg



PFBI L COMBI

Ref. 010523



Condensador Trasero = Laterales Fríos
Rear Condenser Coil = Cold Sides

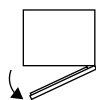

Apertura de serie **Derecha**
Puerta reversible
Standard opening **Right**
Reversible door

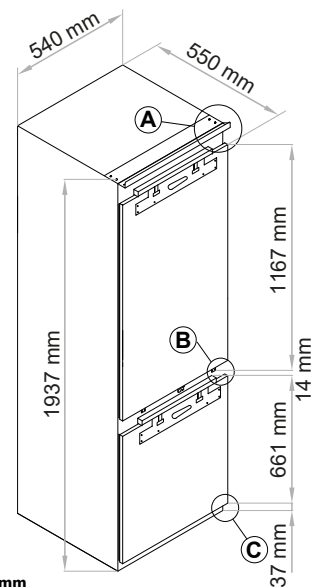
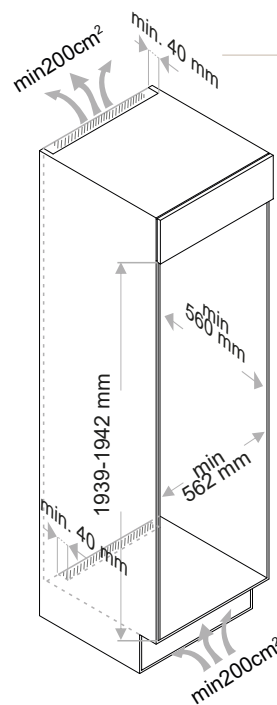
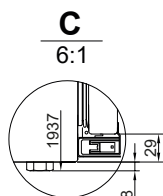
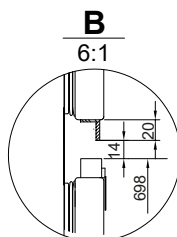
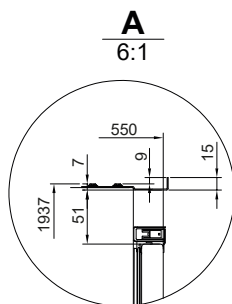

Medidas en / Dimensions in mm



PFBI XL COMBI

Ref. 010522

Frigorífico COMBI de integración panelable 194 x 69
Built-in refrigerator COMBI for overlay decor panel 194 x 69

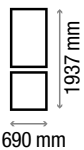

341 L
Capacidad
Capacity



UltraFresh
Technology

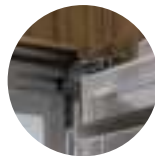

Bisagra profesional.
Puerta Fija
Professional hinge.
"Door-on-Door"



Iluminación LED
pared trasera
Back wall with LED
backlight



257 L
NO Frost
Technology

84 L
NO Frost
Technology

75 cm
Puerta mueble
Cabinet door



Características / Features

Características / Features	Product size (HxWxD)	Value
Dimensiones producto (AlxAxF)	Product size (HxWxD)	1937x690x550 mm
Total Volumen	Total Volume	341 L
Capacidad Frigorífico	Refrigerator Volume	257 L
Capacidad Congelador	Freezer Volume	84 L
Consumo de energía	Energy Consumption	250 kWh/año-year
Nivel de ruido acústico	Noise level	41 dBA
Iluminación interior LED	Interior LED Lighting	Sí / Yes
Clase Climática	Climate Class	Subtropical
Peso máximo puerta panelable	Maximum weight of panel door	45 Kg



PFBI XL COMBI

Ref. 010522



Condensador Trasero = Laterales Fríos
Rear Condenser Coil = Cold Sides

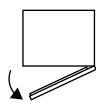

Apertura de serie Derecha
Puerta reversible
Standard opening Right
Reversible door

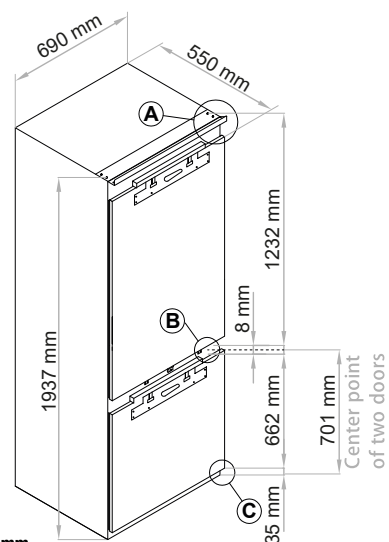
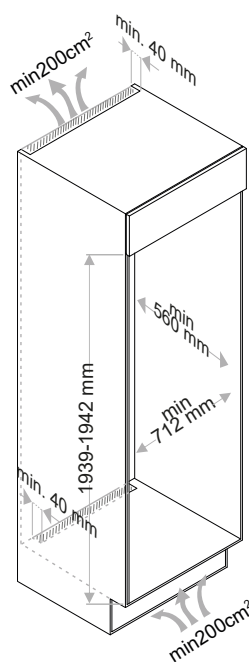
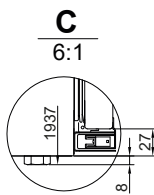
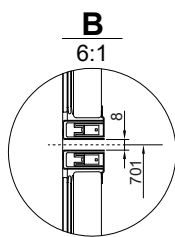
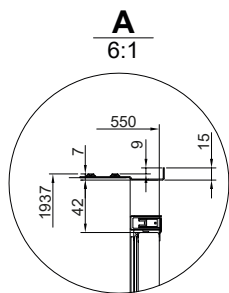

Medidas en / Dimensions in mm



PFBI XL FRIGO

Ref. 010681

Frigorífico de integración panelable 194 x 69
Built-in refrigerator for overlay decor panel 194 x 69

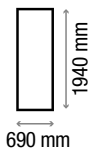

337 L
Capacidad
Capacity

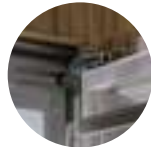

Bisagra profesional.
Puerta Fija
Professional hinge.
"Door-on-Door"



337 L
NO Frost
Technology

75 cm
Puerta mueble
Cabinet door



Características / Features

Dimensiones producto (AlxAnxF)	Product size (HxWxD)	1937x690x550 mm
Total Volumen	Total Volume	337 L
Capacidad Frigorífico	Refrigerator Volume	337 L
Capacidad Congelador	Freezer Volume	---
Consumo de energía	Energy Consumption	165 kWh/año-year
Nivel de ruido acústico	Noise level	39 dBA
Iluminación interior LED	Interior LED Lighting	Sí / Yes
Clase Climática	Climate Class	SubTropical
Peso máximo puerta panelable	Maximum weight of panel door	45 Kg

FUNCIONES: Modo vacaciones | Modo ECO | Modo Rápido | Modo Demo



Condensador Trasero = Laterales Fríos
Rear Condenser Coil = Cold Sides

PFBI XL FRIGO

Ref. 010681



Frigorífico
Iluminación LED pared trasera
Refrigerator
Back wall with LED backlight



Zona inferior frigorífico
Iluminación Tira LED
Inferior zone Freezer
LED Strip Lighting

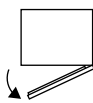

Apertura de serie **Derecha**
Puerta reversible
Standard opening **Right**
Reversible door

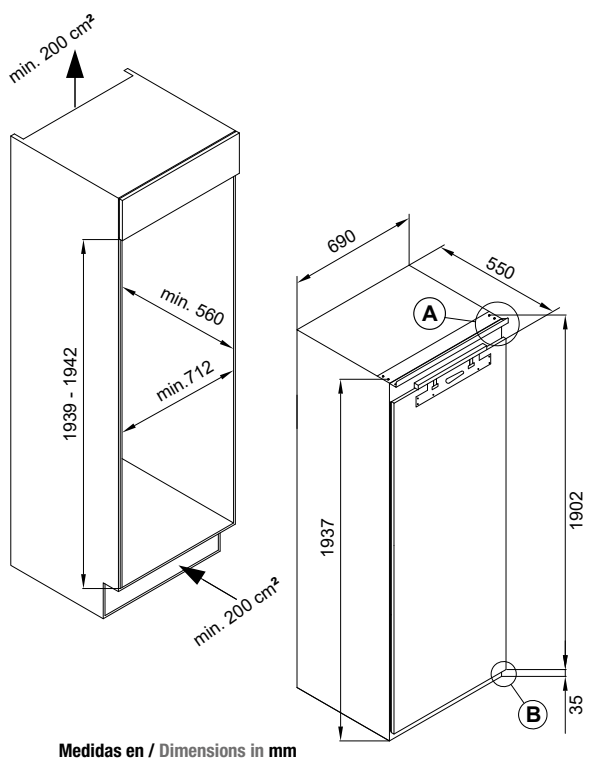
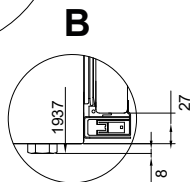
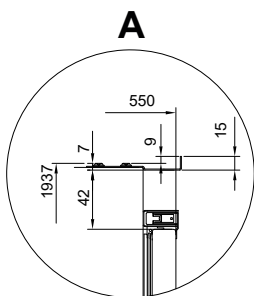

Medidas en / Dimensions in mm



PFLC COMBI

Ref. 010338

Frigorífico COMBI libre instalación. Cristal negro.
Refrigerator COMBI freestanding. Black Glass

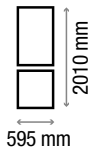

367 L
Capacidad
Capacity



266 L
NO Frost
Technology

101 L
NO Frost
Technology



Características / Features

Dimensiones producto (AlxAnxF)	Product size (HxWxD)	2010x595x660 mm
Total Volumen	Total Volume	367 L
Capacidad Frigorífico	Refrigerator Volume	266 L
Capacidad Congelador	Freezer Volume	101 L
Consumo de energía	Energy Consumption	160 kWh/año-year
Nivel de ruido acústico	Noise level	36 dBA
Metal cooling	Metal cooling	Sí / Yes
Cajón Zona cero	Zero Zone drawer	Sí / Yes
Iluminación interior LED	Interior LED Lighting	Sí / Yes
Clase Climática	Climate Class	Tropical



PFLC COMBI

Ref. 010338



Condensador Trasero = Laterales Fríos
Rear Condenser Coil = Cold Sides

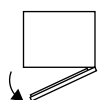

Apertura de serie Derecha
Puerta reversible
Standard opening **Right**
Reversible door

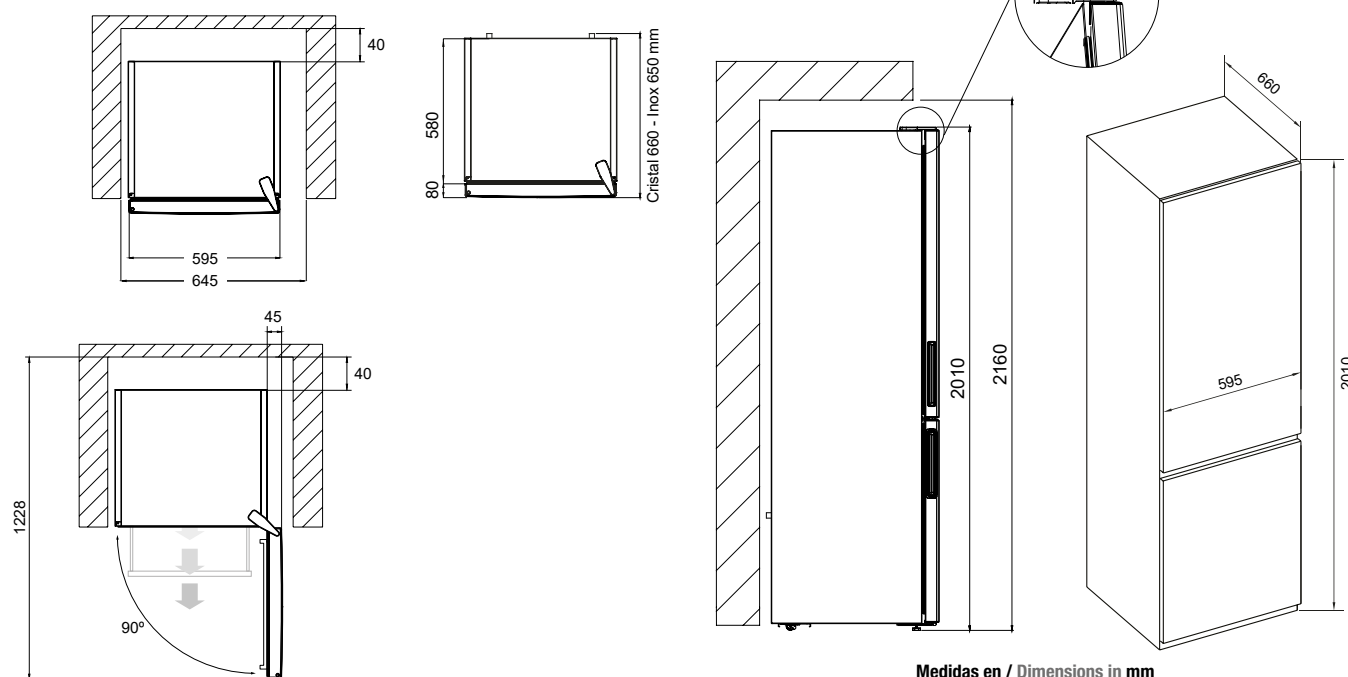

Medidas en / Dimensions in mm



Modelo de 597 mm. de fondo
597 mm. depth model



PFLX AMER L - INOX

Inox / Stainless Steel

Ref. 010717

Frigorífico COMBI Americano libre instalación 4 Puertas
American COMBI Refrigerator freestanding 4 Doors

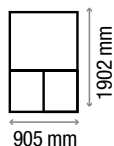

505 L
Capacidad
Capacity



Fondo de 597 mm
Depth of 597 mm



PFLC AMER L

Cristal Negro / Black Glass

Ref. 010716



349 L
NO Frost
Technology

156 L
NO Frost
Technology

Características / Features

Dimensiones producto (AlxAxAnxF)	Product size (HxWxD)	1902 x 905 x 597 mm
Total Volumen	Total Volume	505 L
Capacidad Frigorífico	Refrigerator Volume	349 L
Capacidad Congelador	Freezer Volume	156 L
Consumo de energía	Energy Consumption	249 kWh/año-year
Nivel de ruido acústico	Noise level	39 dBA
Metal cooling	Metal cooling	Sí / Yes
Iluminación interior LED	Interior LED Lighting	Sí / Yes
Clase Climática	Climate Class	Subtropical



Condensador Trasero = Laterales Fríos
Rear Condenser Coil = Cold Sides

PFLX AMER L - INOX

Inox / Stainless Steel

Ref. 010717

PFLC AMER L

Cristal Negro / Black Glass

Ref. 010716

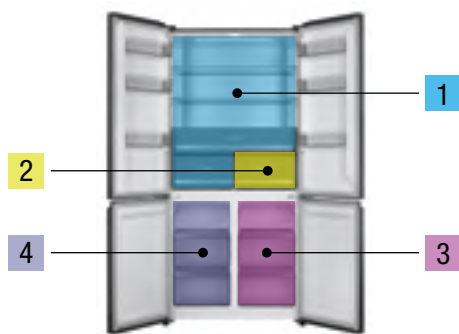

4 Ciclos de frío
Cold cycles

- 1 Frigorífico (2° / 8°)
Refrigerator (2° / 8°)
- 2 Zona de refrigeración (-1,5° / 0° / 3°)
Chiller Zone (-1,5° / 0° / 3°)
- 3 Zona convertible (-20° / 5°)
Convertible Zone (-20° / 5°)
- 4 Congelador (-14° / -22°)
Freezer compartment (-14° / -22°)

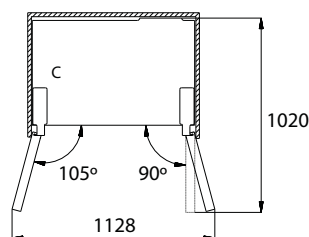
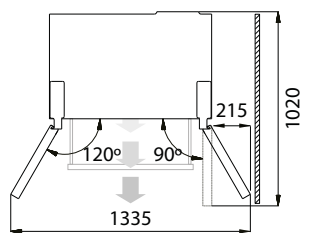

Medidas en / Dimensions in mm

Por sus dimensiones queda totalmente enrasado con el resto del mobiliario
Due to its dimensions, it is completely flush with the rest of the furniture

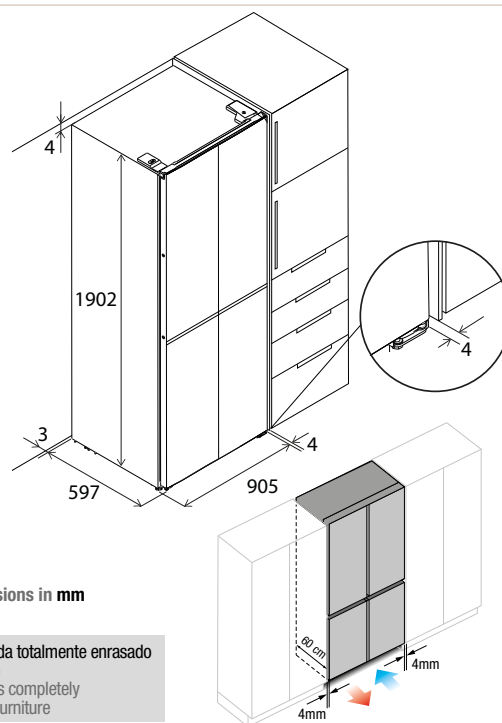



PFLC AMER XL

Ref. 010718 Cristal negro / Black glass

Frigorífico COMBI Americano libre instalación 4 Puertas
American COMBI Refrigerator freestanding 4 Doors

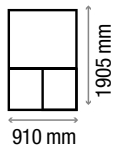

600 L
Capacidad
Capacity



Fondo de 690 mm
Depth of 690 mm



429 L
NO Frost
Technology

171 L
NO Frost
Technology



Características / Features

Características / Features	Product size (HxWxD)	1905x910x690 mm
Dimensiones producto (AlxAnxF)	Total Volumen	600 L
Total Volumen	Refrigerator Volume	429 L
Capacidad Frigorífico	Freezer Volume	171 L
Capacidad Congelador	Energy Consumption	261 kWh/año-year
Consumo de energía	Noise level	39 dBA
Nivel de ruido acústico	Metal cooling	Sí / Yes
Metal cooling	Interior LED Lighting	Sí / Yes
Iluminación interior LED	Climate Class	Subtropical
Clase Climática		



Condensador Trasero = Laterales Fríos
Rear Condenser Coil = Cold Sides

600 L
Capacidad
TOTAL
Capacity

PFLC AMER XL

Ref. 010718 Cristal negro / Black glass

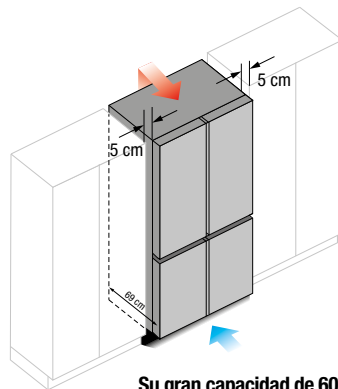

Su gran capacidad de 600 L lo convierten en un auténtico XL
Its large capacity of 600 L makes it a true XL

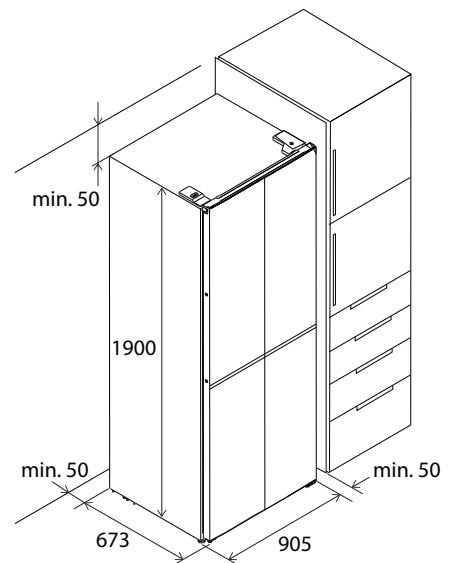
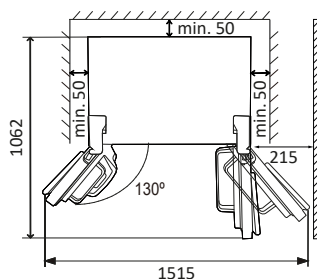

Medidas en / Dimensions in mm

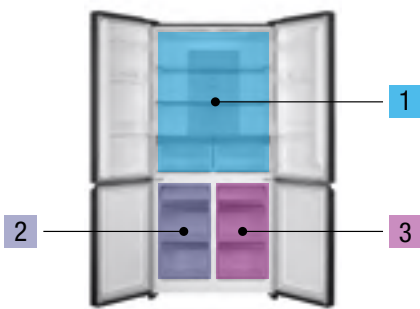

3 Ciclos de frío
Cold cycles

- 1** Frigorífico (2° / 8°)
Refrigerator (2° / 8°)
- 2** Congelador (-14° / -22°)
Freezer compartment (-14° / -22°)
- 3** Zona convertible (-20° / 5°)
Convertible Zone (-20° / 5°)

Drink cooling center

Una gama que ha sido especialmente diseñada para mantener, de una forma ordenada y muy eficaz, la temperatura justa de nuestras bebidas más selectas. Ideal para hogares o clientes, que se toman muy en serio aquellos momentos únicos, donde disfrutar de una bebida refrescante se convierte en toda una experiencia.



The range that has been specially designed to always maintain, in an orderly and very effective way, your most select drinks at just the right temperature. Pando Beverage Coolers are perfect for any residential home or clients, who likes to enjoy those unique moments, where having a cool, refreshing drink becomes a great experience.







PFMB 60 PFMBP 60

**Drink Cooling Center. Libre instalación
Beverage Cooler. Freestanding**

Iluminación **Multicolor**
3 intensidades
Multicolour Lighting
3 intensity levels

Blanco, azul y ambar
White, blue and amber



Cajón inferior extraíble con guías telescópicas
Pull-out lower drawer with telescopic guides

Características / Features

Dimensiones producto - AlxAxF (mm)	Product Dimensions - HxWxD (mm)	815 x 595 x 556
Dimensiones encastre - AlxAxF (mm)	Built-in Dimensions - HxWxD (mm)	822 x 600 x ≥575
Profundidad sin tirador_D (mm)	Depth without handle (mm)	556
Profundidad con tirador (mm)	Depth with handle (mm)	596
Profundidad y altura zócalo_DxH (mm)	Depth and height base_DxH (mm)	72 x 95
Secciones de frío	Temperature zones	1
Temperatura operativa	Operating Range (°C)	2~12°C
Control temperatura	Temperature Control	Electrón.-Digital
Indicador temperatura display en °C/°F	°C/°F Temperature Display	Sí / Yes
Nº Estantes	Trays	2
Nº Cajón Contenedor	Container Drawer	1
Nº Compartimento fijo	Fixed compartment	1
Base de cristal en Estante superior	Glass base on top shelf	Sí / Yes
Interruptor luz	Light Switch	Sí / Yes
Tensión (V) / Frecuencia (Hz)	Voltage (V) / Frequency (Hz)	220-240V / 50Hz
Clase energética desde 2021	Energy Efficiency Class	C
Clase climática	Climate Class	ST
Consumo energético (Kwh/ año)	Energy Consumption (kWh/y.r)	255
Potencia sonora LwA (dBA) / 2021	Sound level LwA (dB(A) re 1 pW)	40
Capacidad, Volumen almacenamiento (l)	Capacity, Storage Volume (l)	125
Nº cristales puerta	Number of Layers for Glass Door	3
Cristal puerta Filtro UV/ Cristal templado	Anti UV Glass/ Tempered glass	Sí / Yes
Ángulo apertura de la puerta	Door Opening Angle	95°-115°
Ventilación Frontal plinht	Ventilation frontal plinht	Sí / Yes
Alarma puerta abierta	Door open alert system	Sí / Yes
Alarma temperatura	Temperature Alarm System	Sí / Yes
Defrost (Descongelado)	Defrosting	Auto.
Multicolor	Multicolor	Sí / Yes



+info



PFMB 60

Acabados / Finishing	Apertura / opens to	Ref. / Ref.
Cristal Negro Black glass	Der./Right	010841
	Izq./Left	010840
Inox Stainless steel	Der./Right	010843
	Izq./Left	010842



+info



PFMBP 60 PUSH TO OPEN

Acabados / Finishing	Apertura / opens to	Ref. / Ref.
Cristal Negro Black glass	Der./Right	010845
	Izq./Left	010844
Inox Stainless steel	Der./Right	010847
	Izq./Left	010846

PFMB 60 / PFMBP 60

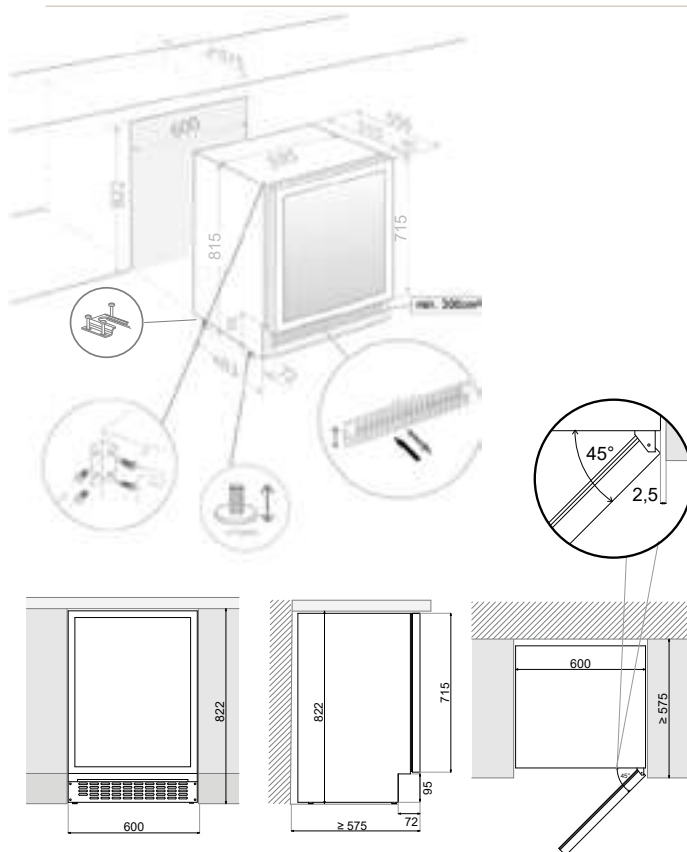

Medidas en / Dimensions in mm

Vinotecas

El placer de degustar
un buen vino

Con la experiencia transmitida por los viejos bodegueros, hemos preparado minuciosamente el lugar ideal para que sus más preciados vinos siempre estén en su punto justo de degustación.

Wine coolers

The pleasure of tasting a wine
at just the right temperature.

With the passion and experience of true wine connoisseurs, when installing one of Pando's exclusive wine coolers, you can have the pleasure of enjoying your fine wines at just the right temperature.







Vinotecas bajo encimera Under counter wine coolers

82 cm

PVZB 15-9

Anchura / Size: 15 cm
Botellas / Bottles: 9
p. 308

PVMB 30-16

Anchura / Size: 30 cm
Botellas / Bottles: 16
p. 310

PVMB 40-28

Anchura / Size: 40 cm
Botellas / Bottles: 28
p. 312

PVMB 60-46

Anchura / Size: 60 cm
Botellas / Bottles: 46
p. 314

PVMBP 60-44 PVMBP 60-44 PA

Anchura / Size: 60 cm
Botellas / Bottles: 44
p. 316 / 338

PVMBP HD 40-25 *

Anchura / Size: 40 cm
Botellas / Bottles: 25
p. 312

PVMBP HD 60-52 * PVMBP HD 60-52 PA *

Anchura / Size: 60 cm
Botellas / Bottles: 52
p. 316 / 340

(*)
Modelos HD con puerta de
78 cm de altura
HD models with door
height 78 cm
304 - Pando



Vinotecas mueble alto Built-in wine coolers

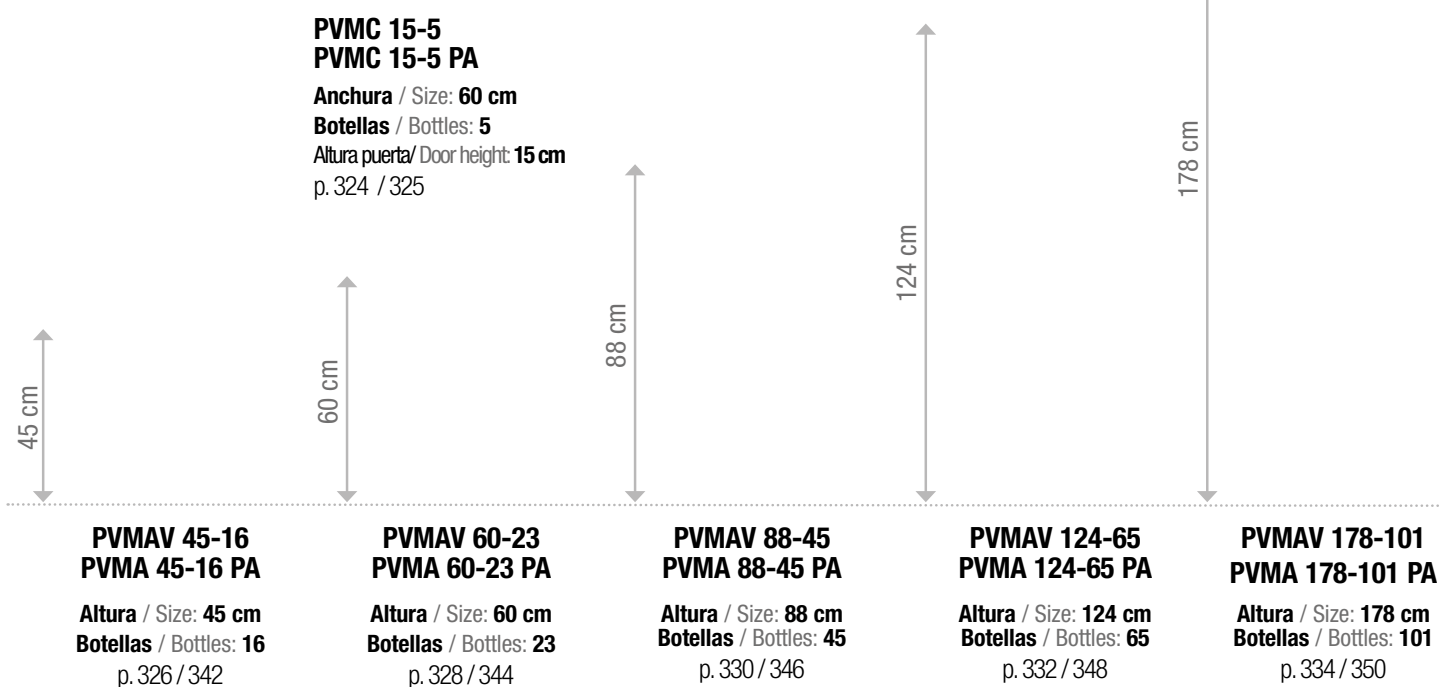

Vinotecas libre instalación / Freestanding wine cooler

Altura / Size: 180 cm
Botellas / Bottles: 110
LIBRE INSTALACIÓN
p. 318

Altura / Size: 180 cm
Botellas / Bottles: 165
LIBRE INSTALACIÓN
p. 320

Vinotecas Wine coolers

Genuinas vinotecas que marcan la diferencia
Wine coolers for the distinguished connoisseur

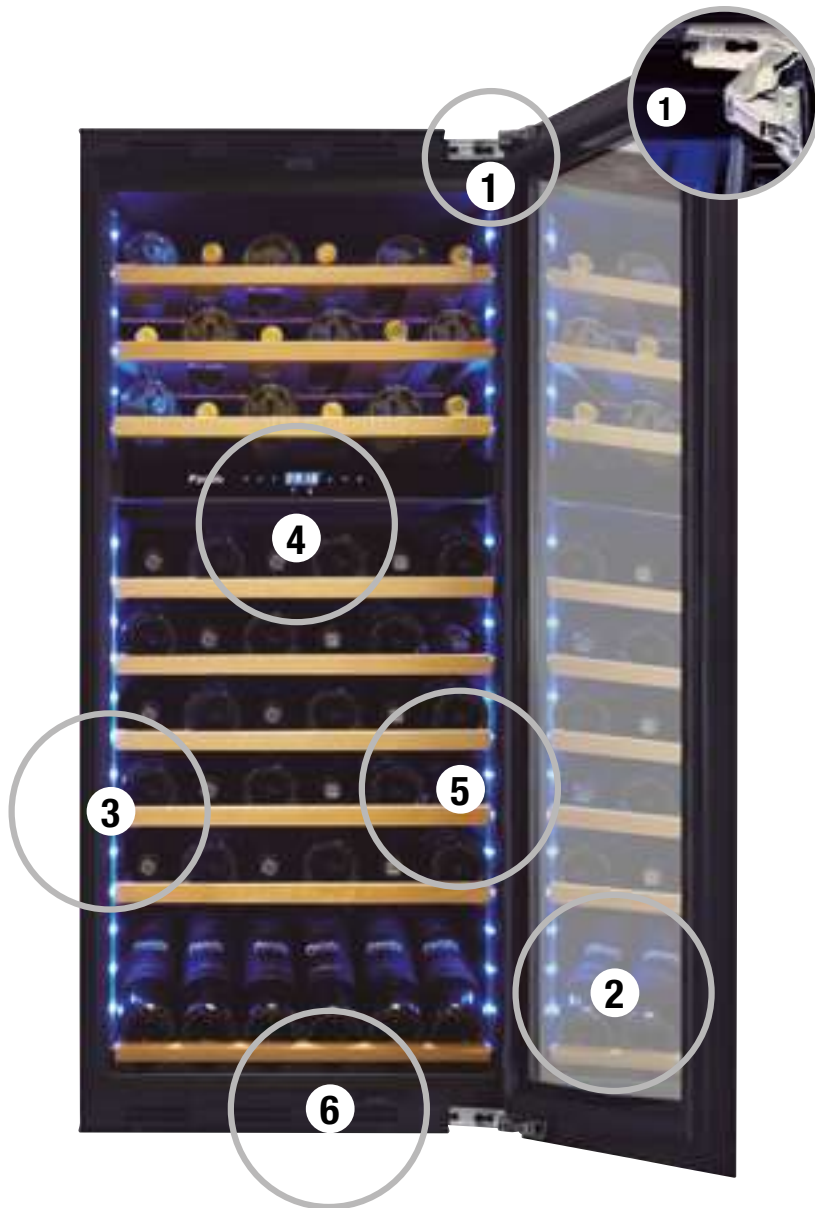

1 Soft-Close

- Bisagra profesional alemana (Hettich) de alta resistencia con sistema Soft-Close para vinotecas de integración en mueble alto y en algunos modelos de mueble bajo.
- German professional hinge (Hettich) with Soft-Close mechanism for built-in wine coolers and in some models of under counter.

2 Conservación perfecta Perfect conservation

- Puerta de triple cristal templado
- Filtro solar ahumado anti luz UV
- Clase climática Sub-tropical
- Calefactor
- Filtro Carbón activado contra olores
- Triple tempered glass door
- UV Protected smoked glass
- Sub-tropical climate class
- Heater
- Activated carbon filter against odor

3 Luz LED Multicolor interior (Blanca, Azul y Ambar) con 3 intensidades Interior Multicolour LED light (White, Blue and Amber) with 3 intensities

- Iluminación interior Multicolor (Blanca, Azul y Ambar)
- Luz LED interior con 3 intensidades lúminicas
- Luz interior programable con encendido permanente o encendido ajustado a la apertura de la puerta
- Multicolor interior lighting (White, Blue and Amber)
- Interior LED light with 3 intensities
- Programmable interior LED light permanent on or only on if door is open

4 Panel de control LCD LCD Control panel

- Iluminación Multicolor (Blanca, Azul y Ambar)
- 3 intensidades lúminicas
- Display con termostato y control digital
- Temperatura en C° y F°
- Memoria de temperatura
- Modo reposo (Display y Acustic off)
- Sistemas de alerta de puerta abierta y de funcionamiento
- Multicolour Lighting (White, Blue and Amber)
- 3 light intensity levels
- Display with thermostat and digital control
- Temperature in C° and F°
- Temperature memory
- Energy saving mode (Display and Acustic off)
- Open door alert system

5 Guías telescópicas Telescopic guides

- Estantes haya natural con guías telescópicas
- Cuerpo interior negro
- Beechwood shelves with telescopic guides
- Black interior

6 Compresor inverter Inverter compressor

- Muy silencioso
- Máxima eficiencia energética
- Soportes antivibratorios
- Very silent
- Highest energy efficiency
- Anti-vibration mounts



Luz interior LED
Multicolor con
3 intensidades

Multicolour LED
interior light
with 3 intensities

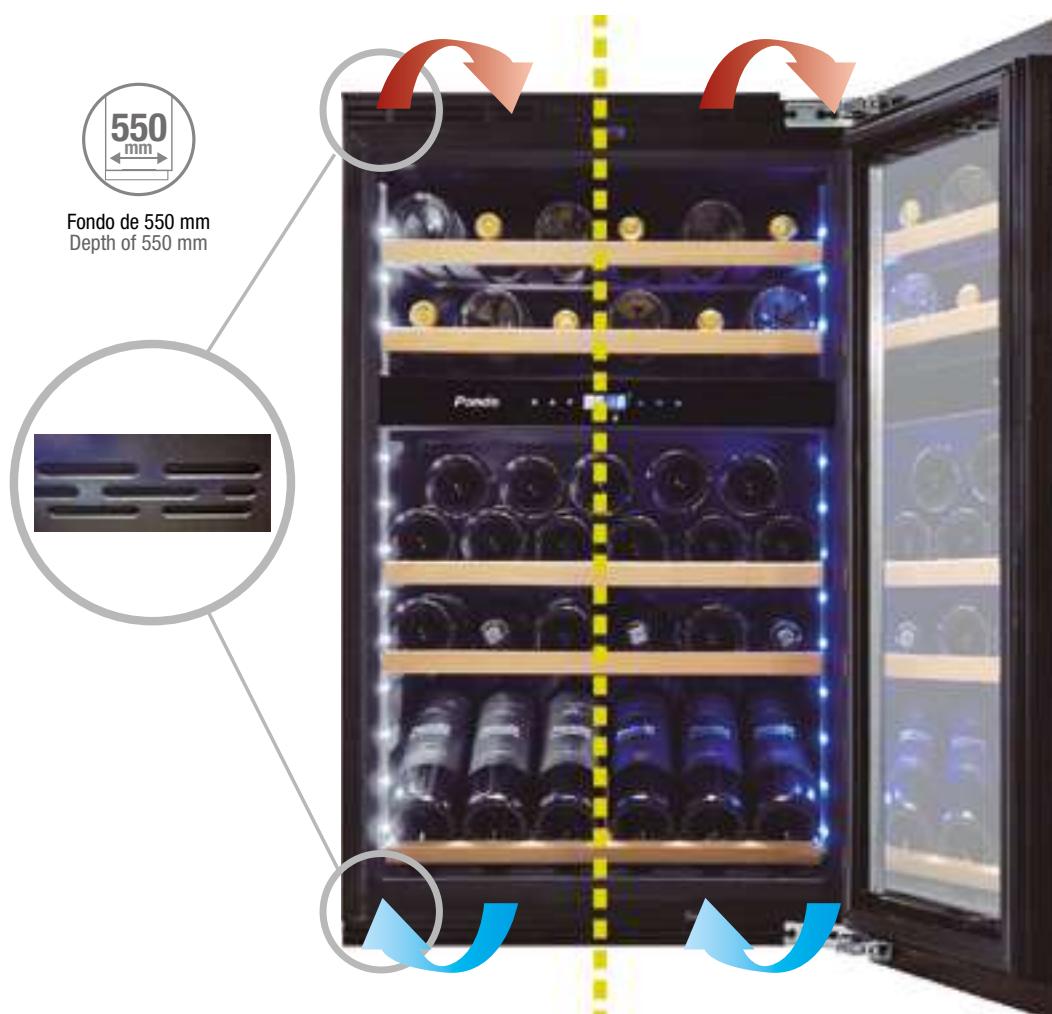

Sistema exclusivo de **Pando**
con **ventilación integrada** y
clima dinámico

Built-in ventilation system
by **Pando** and
dynamic climate control

SVI
Sistema de Ventilación Integrada Pando
Únicamente para vinotecas de integración en mueble alto.

SVI
Built-in ventilation system
Only for built-in wine coolers.

El Sistema de Ventilación Integrada de Pando, facilita la colocación en cualquier tipo de mobiliario ya que no precisa de rejillas de ventilación en zócalo, zona alta o de una capacidad extra interior.

The Built-In Ventilation System by Pando, allows the wine cooler to be fitted in any kind of furniture as it does not require ventilation grilles at the top or bottom, or extra space at the back of the installed unit. This ventilation system ensures precise, independent cooling in the unit, regardless of the temperature outside it. It will always function perfectly and without maintenance.

El SVI permite una perfecta y autónoma refrigeración de la vinoteca, con independencia del clima exterior. El funcionamiento siempre será perfecto y sin mantenimiento.

Sistema de climatización dinámico

Dynamic climate control system

Solo una auténtica vinoteca incorpora un sistema de climatización dinámico, que permite poner en temperatura todas y cada una de las botellas de vino que tengamos en su interior. El sistema de ventilación climatizada permite, mediante sus diferentes ventiladores internos, asegurar que todas las partes de cada botella, tengan la misma temperatura, asegurando así una óptima y excelente conservación.

Only a true wine cooler features a dynamic climate control system to keep each and every one of the bottles of wine inside it at the desired temperature. The different internal fans allow the climate-control ventilation system to ensure that every part of every bottle is kept at the same temperature, so providing excellent, reliable storage.



PVZB 15-9

Vinoteca bajo encimera
Under counter wine cooler



15 cm
Anchura mueble
Size (Width)

1
Sección de frío
Temperature zone

● Iluminación interior azul o blanca
Blue or white interior lighting



Código Code	Referencia Product code	Acabados Finishing	Versión Version	Apertura Opens to
----------------	----------------------------	-----------------------	--------------------	----------------------

LUZ AZUL / BLUE LIGHT

010883	PVZB 15-9 CRR	Cristal Negro Black glass	Con tirador With handle	Der./Right
010884	PVZB 15-9 CRL			Izq./Left
010885	PVZB 15-9 XR	Inox S/Steel		Der./Right
010886	PVZB 15-9 XL			Izq./Left

LUZ BLANCA / WHITE LIGHT

010887	PVZB 15-9 CRR-W	Cristal Negro Black glass	Con tirador With handle	Der./Right
010888	PVZB 15-9 CRL-W			Izq./Left
010889	PVZB 15-9 XR-W	Inox S/Steel		Der./Right
010890	PVZB 15-9 XL-W			Izq./Left

Características / Features

Nº de botellas (tipo burdeos 0,75 litros)	Number of bottles (bordeaux type 0,75 ltrs)	9
Dimensiones (An x Al x F)	Dimensions (W x H x D)	150x825x525 mm
Secciones de frío	Temperature zones	1
Temperatura operativa	Temperature range	+5°C a +20°C
Capacidad (litros)	Capacity (ltrs)	22
Consumo energético	Energy consumption	106 kWh/año-year
Nivel sonoro	Noise Level	38 db
Nº de cristales en la puerta	Num. of glasses in the door	3
Guías telescópicas	Telescopic guides	No
Compresor inverter	Inverter compresor	No



PVZB 15-9

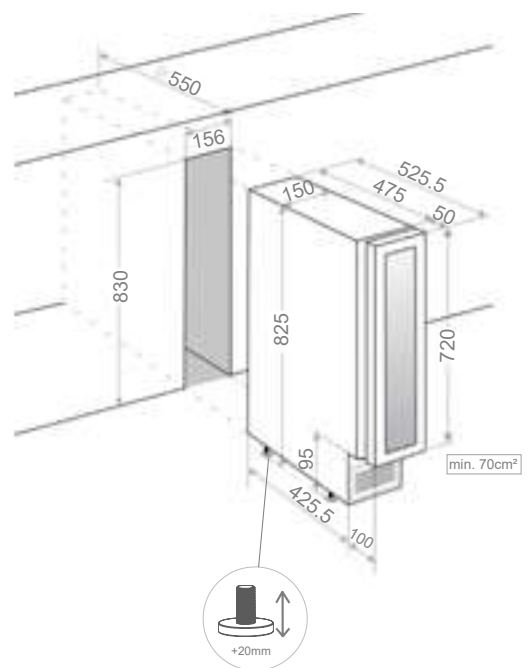
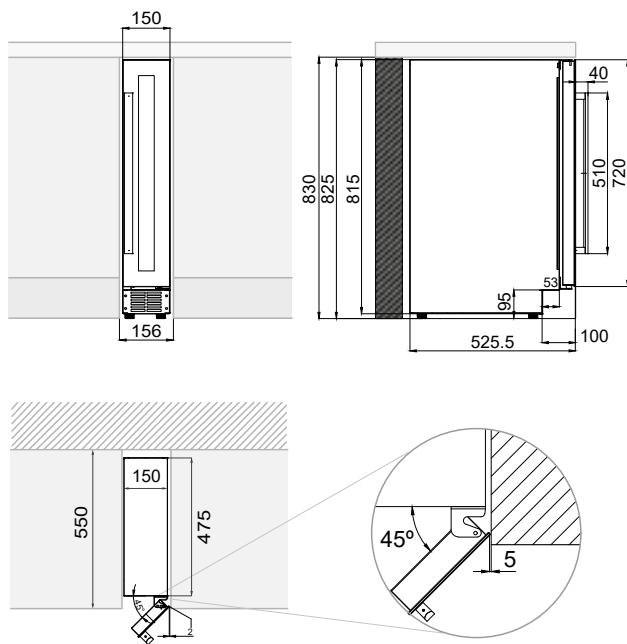

Patas regulables en altura de 10 a 20
Adjustable legs from 10 to 20

Medidas en / Dimensions in mm



PVMB 30-16

Vinoteca bajo encimera
Under counter wine cooler

16
Ø75mm
300 mm

30 cm
Anchura mueble
Size (Width)

2
Secciones de frío
Temperature zones

Compresor INVERTER
INVERTER compressor

 Iluminación **Multicolor**
3 intensidades
Multicolour Lighting
3 intensity levels



Código Code	Referencia Product code	Acabados Finishing	Versión Version	Apertura Opens to
010721	PVMB 30-16 CRR	Cristal Negro Black glass	Con tirador With handle	Der./Right
010720	PVMB 30-16 CRL			Izq./Left
010723	PVMB 30-16 XR	Inox S/Steel		Der./Right
010722	PVMB 30-16 XL			Izq./Left

Características / Features

Nº de botellas (tipo burdeos 0,75 litros)	Number of bottles (bordeaux type 0,75 ltrs)	16
Dimensiones (An x Al x F)	Dimensions (W x H x D)	295 x 820 x 575 mm
Secciones de frío	Temperature zones	2
Temperatura operativa	Temperature range	+5°C a +20°C
Capacidad (litros)	Capacity (ltrs)	52
Consumo energético	Energy consumption	98 KwH/año-year
Nivel sonoro	Noise Level	35 db
Nº de cristales en la puerta	Number of glasses in the door	3
Filtro carbón activado	Activated carbon filter	Si/Yes
Guías telescópicas	Telescopic guides	No

Opcional / Optional

010189 Kit cerradura vinoteca / With door lock



PVMB 30-16

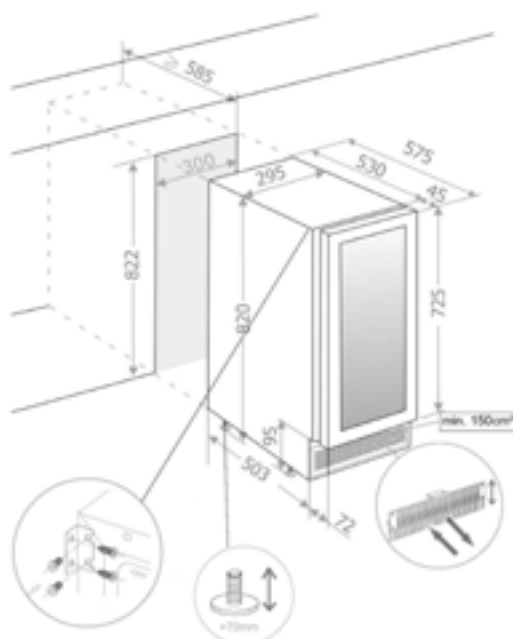
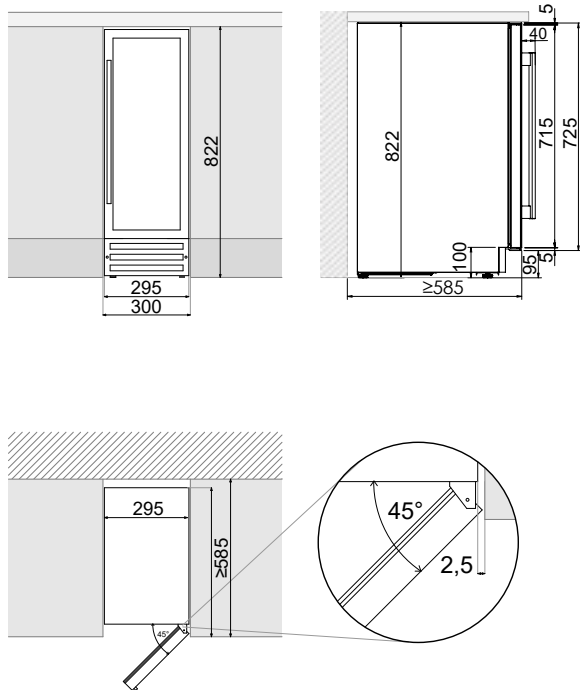

Patas regulables en altura de 10 a 70
Adjustable legs from 10 to 70

Medidas en / Dimensions in mm



PVMB 40-28 / PVMBP HD 40-25

Vinoteca bajo encimera
Under counter wine cooler

28 / 25
Ø75mm 300 mm

40 cm
Anchura mueble
Size (Width)

2
Secciones de frío
Temperature zones

Compresor INVERTER
INVERTER compressor

 Iluminación **Multicolor**
3 intensidades
Multicolour Lighting
3 intensity levels



Altura de la puerta
Door height



Altura de la puerta
Door height



Código Code	Referencia Product code	Acabados Finishing	Versión Version	Apertura Opens to
----------------	----------------------------	-----------------------	--------------------	----------------------

PVMB 40-28

010725	PVMB 40-28 CRR	Cristal Negro Black glass	Con tirador With handle	Der./Right
010724	PVMB 40-28 CRL			Izq./Left

PVMBP HD 40-25

010727	PVMBP HD 40-25 CRR	Cristal Negro Black glass	PUSH-TO-OPEN	Der./Right
010726	PVMBP HD 40-25 CRL			Izq./Left

Características / Features

Nº de botellas (tipo burdeos 0,75 litros)	Number of bottles (bordeaux type 0,75 ltrs)	28 / 25
Dimensiones PVMB 40-28	Dimensions PVMBP 40-28	395x820x575 mm
Dimensiones PVMBP HD 40-25	Dimensions PVMBP HD 40-25	395x880x575 mm
Secciones de frío	Temperature zones	2
Temperatura operativa	Temperature range	+5°C a +20°C
Capacidad (litros)	Capacity (ltrs)	75 / 80
Consumo energético	Energy consumption	100 kWh/año-year
Nivel sonoro	Noise Level	35 db
Nº de cristales en la puerta	Num. of glasses in the door	3
Filtro carbón activado	Activated carbon filter	Si/Yes
Guías telescópicas	Telescopic guides	No

Opcional / Optional

010189 Kit cerradura vinoteca / With door lock



Altura de la puerta
Door height

PVMB 40-28

Esquemas medidas / Technical Drawings

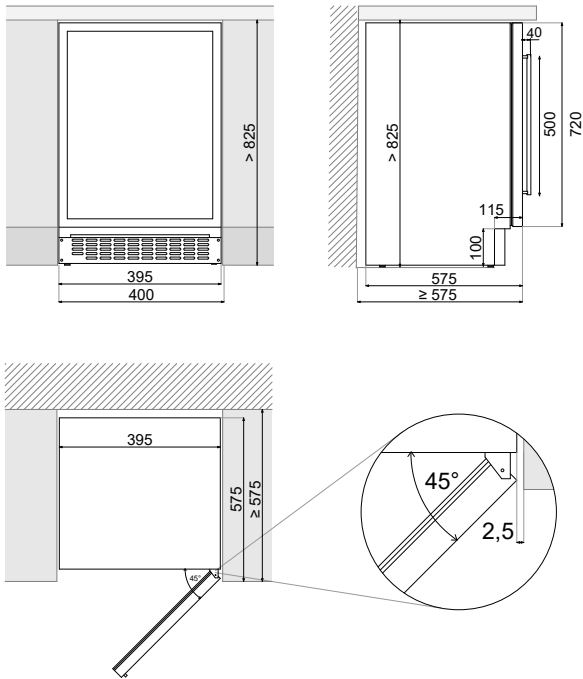

Medidas en / Dimensions in mm

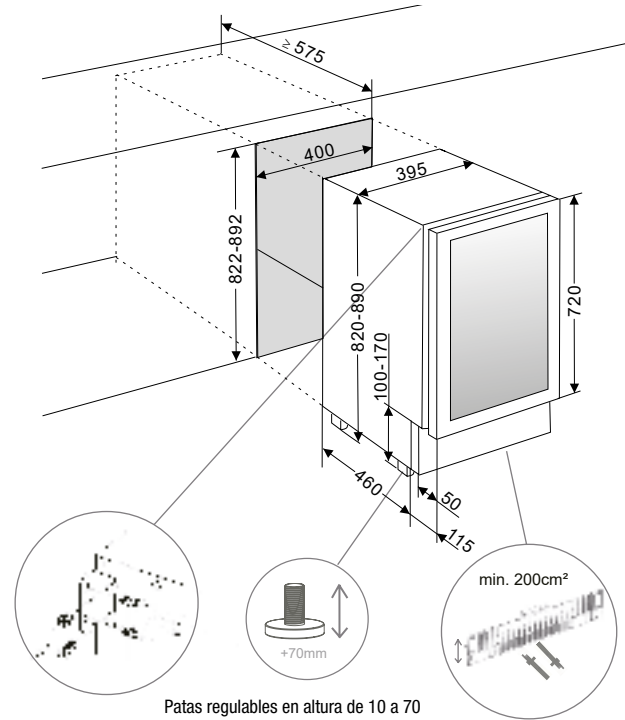

Patas regulables en altura de 10 a 70
Adjustable legs from 10 to 70



Altura de la puerta
Door height

PVMBP HD 40-25

Esquemas medidas / Technical Drawings

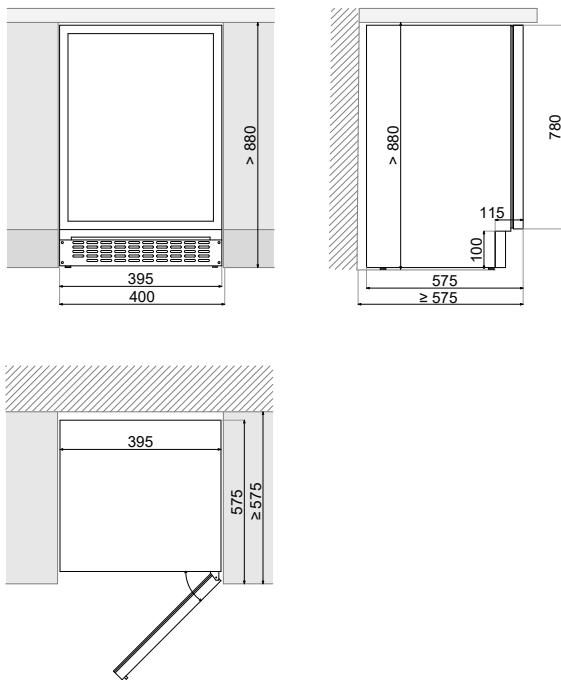

Medidas en / Dimensions in mm

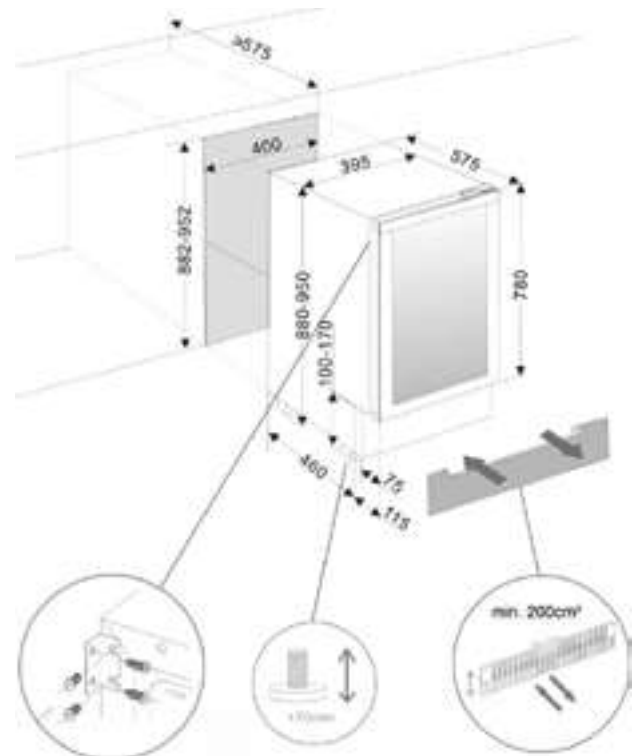

Patas regulables en altura de 10 a 70
Adjustable legs from 10 to 70



PVMB 60-46

Vinoteca bajo encimera
Under counter wine cooler



60 cm

Anchura mueble
Size (Width)

2

Secciones de frío
Temperature zones



Compresor INVERTER
INVERTER compressor



Iluminación **Multicolor**
3 intensidades
Multicolour Lighting
3 intensity levels



Altura de la puerta
Door height



Código Code	Referencia Product code	Acabados Finishing	Versión Version	Apertura Opens to
010729	PVMB 60-46 CRR	Cristal Negro Black glass	Con tirador With handle	Der./Right
010728	PVMB 60-46 CRL			Izq./Left
010731	PVMB 60-46 XR	Inox S/Steel		Der./Right
010730	PVMB 60-46 XL			Izq./Left

Características / Features

Nº de botellas (tipo burdeos 0,75 litros)	Number of bottles (bordeaux type 0,75 ltrs)	46
Dimensiones (An x Al x F)	Dimensions (W x H x D)	595x820x575 mm
Secciones de frío	Temperature zones	2
Temperatura operativa	Temperature range	+5°C a +20°C
Capacidad (litros)	Capacity (ltrs)	125
Consumo energético	Energy consumption	104 kWh/año-year
Nivel sonoro	Noise Level	35 db
Nº de cristales en la puerta	Num. of glasses in the door	3
Filtro carbón activado	Activated carbon filter	Si/Yes
Guías telescópicas	Telescopic guides	Si/Yes



PVMB 60-46

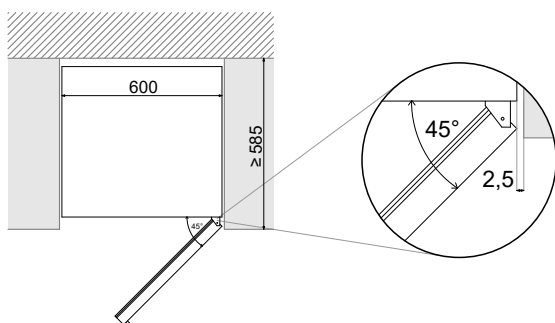
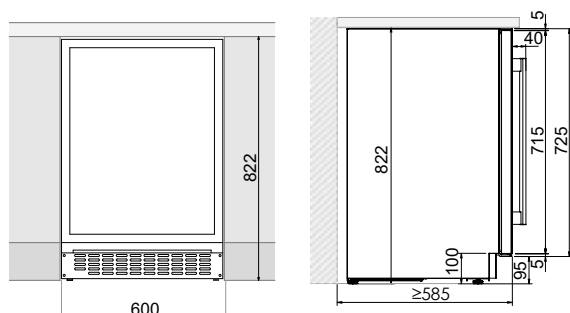

Opcional / Optional

010189 Kit cerradura vinoteca / With door lock 105 €

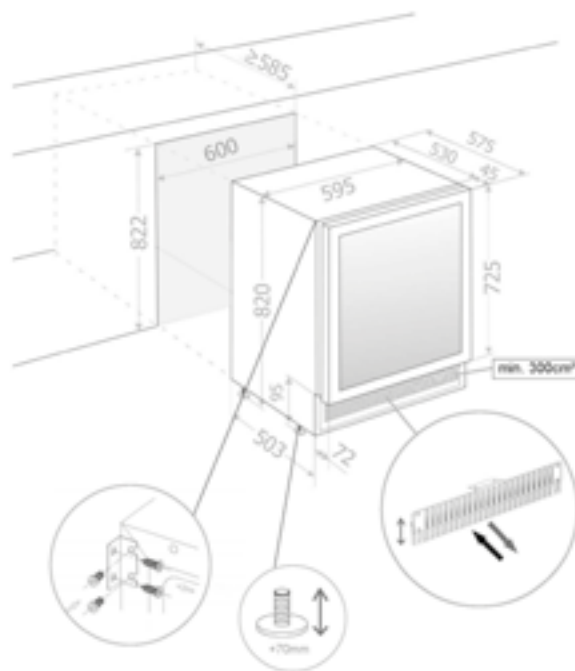

Patas regulables en altura de 10 a 70
Adjustable legs from 10 to 70

Medidas en / Dimensions in mm



PVMBP 60-44 / PVMBP HD 60-52

Vinoteca bajo encimera
Under counter wine cooler

44 / 52
Ø75mm
300 mm

60 cm
Anchura mueble
Size (Width)

2
Secciones de frío
Temperature zones

Compresor INVERTER
INVERTER compressor

 Iluminación **Multicolor**
3 intensidades
Multicolour Lighting
3 intensity levels



72

Altura de la puerta
Door height

78

Altura de la puerta
Door height

PUSH



Bisagra profesional
Professional German hinge
"Soft-Close"

Características / Features

Nº de botellas (tipo burdeos 0,75 litros)	Number of bottles (bordeaux type 0,75 ltrs)	44 / 52
Dimensiones PVMBP 60-44	Dimensions PVMBP 60-44	595x820x575 mm
Dimensiones PVMBP HD 60-52	Dimensions PVMBP HD 60-52	595x880x575 mm
Secciones de frío	Temperature zones	2
Temperatura operativa	Temperature range	+5°C a +20°C
Capacidad (litros)	Capacity (ltrs)	116 / 130
Consumo energético	Energy consumption	104/105 kWh/año-year
Nivel sonoro	Noise Level	35 db
Calefactor	Heater	No
Nº de cristales en la puerta	Number of glasses in the door	3
Filtro carbón activado	Activated carbon filter	Si/Yes
Guías telescópicas	Telescopic guides	Si/Yes

Dimensiones (An x Al x F)

Dimensions (W x H x D)

Opcional / Optional

010189 Kit cerradura vinoteca / With door lock



Altura de la puerta
Door height

PVMBP 60-44

Esquemas medidas / Technical Drawings

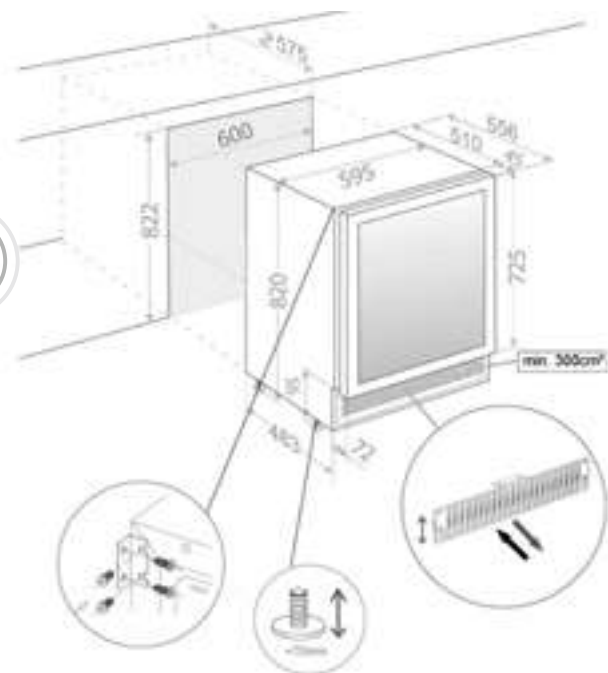
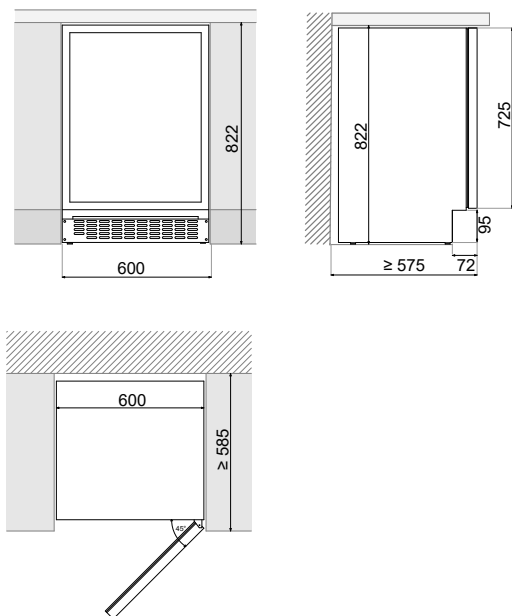

Patas regulables en altura de 10 a 70
Adjustable legs from 10 to 70

Medidas en / Dimensions in mm

PVMBP 60-44

Código Code	Referencia Product code	Acabados Finishing	Versión Version	Apertura Opens to
010733	PVMBP 60-44 CRR	Cristal Negro Black glass	PUSH-TO- OPEN	Der./Right
010732	PVMBP 60-44 CRL			Izq./Left
010735	PVMBP 60-44 XR	Inox S/Steel		Der./Right
010734	PVMBP 60-44 XL			Izq./Left



Altura de la puerta
Door height

PVMBP HD 60-52

Esquemas medidas / Technical Drawings

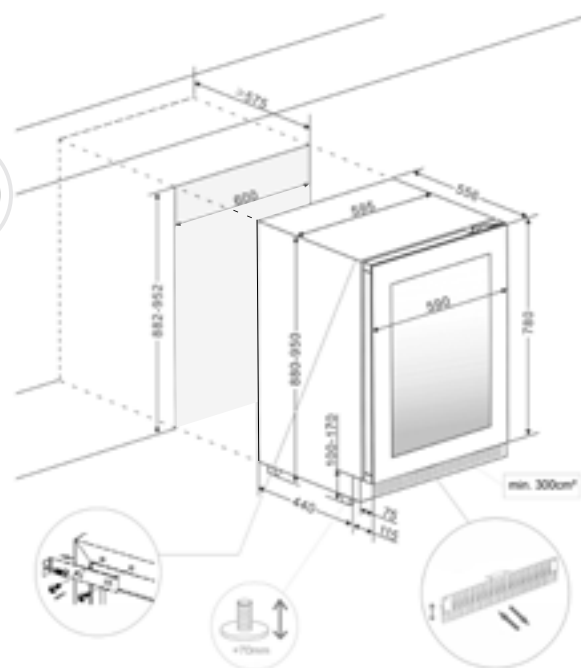
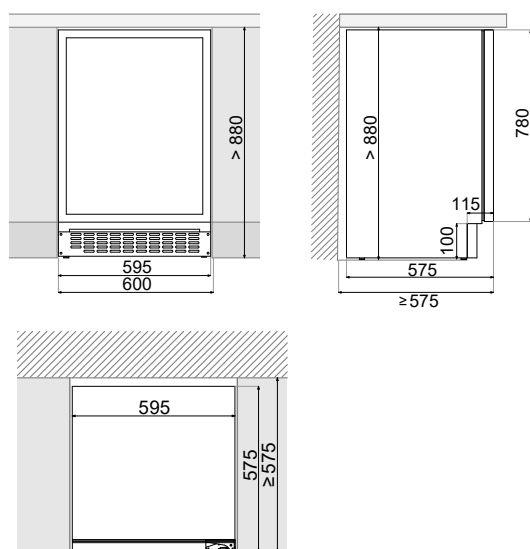

Patas regulables en altura de 10 a 70
Adjustable legs from 10 to 70

Medidas en / Dimensions in mm

PVMBP HD 60-52

Código Code	Referencia Product code	Acabados Finishing	Versión Version	Apertura Opens to
010737	PVMBP HD 60-52 CRR	Cristal Negro Black glass	PUSH-TO- OPEN	Der./Right
010736	PVMBP HD 60-52 CRL			Izq./Left

New
Collection



Fondo de 550 mm
Depth of 550 mm

MODELO LIBRE INSTALACIÓN
FREESTANDING MODEL

Por sus dimensiones, queda totalmente enrasada con el resto del mobiliario
Due to its dimensions, it is completely flush with the rest of the furniture



PVZB 180-110
Vinoteca libre instalación
Freestanding wine cooler



180 cm
Altura mueble
Size (Height)

2

Sección de frío
Temperature zone



Compresor INVERTER
INVERTER compressor



Iluminación interior azul
Blue interior lighting



Guías telescópicas
Telescopic guides

Código Code	Referencia Product code	Acabados Finishing	Versión Version	Apertura Opens to
----------------	----------------------------	-----------------------	--------------------	----------------------

LUZ AZUL / BLUE LIGHT

010797	PVZB 180-110 CRR	Cristal Negro Black glass	Con tirador With handle	Der. / Right
010798	PVZB 180-110 CRL			Izq. / Left

Características / Features

Nº de botellas (tipo burdeos 0,75 litros)	Number of bottles (bordeaux type 0,75 ltrs)	110
Dimensiones (An x Al x F)	Dimensions (W x H x D)	595 x 1792 x 550 mm
Secciones de frío	Temperature zones	2
Temperatura operativa	Temperature range	+5°C a +20°C
Capacidad (litros)	Capacity (ltrs)	318
Consumo energético	Energy consumption	151 kWh/año-year
Nivel sonoro	Noise Level	38 db
Nº de cristales en la puerta	Num. of glasses in the door	2
Filtro carbón activado	Activated carbon filter	Si/Yes
Guías telescópicas	Telescopic guides	Si/Yes



PVZB 180-110



Fondo de 550 mm
Depth of 550 mm

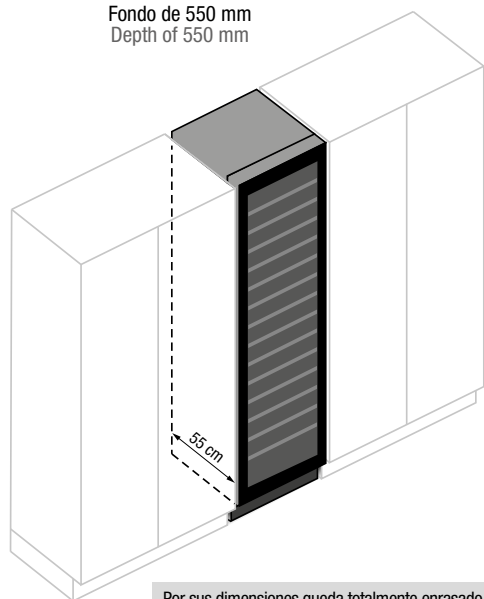

Por sus dimensiones queda totalmente enrasado con el resto del mobiliario
Due to its dimensions, it is completely flush with the rest of the furniture

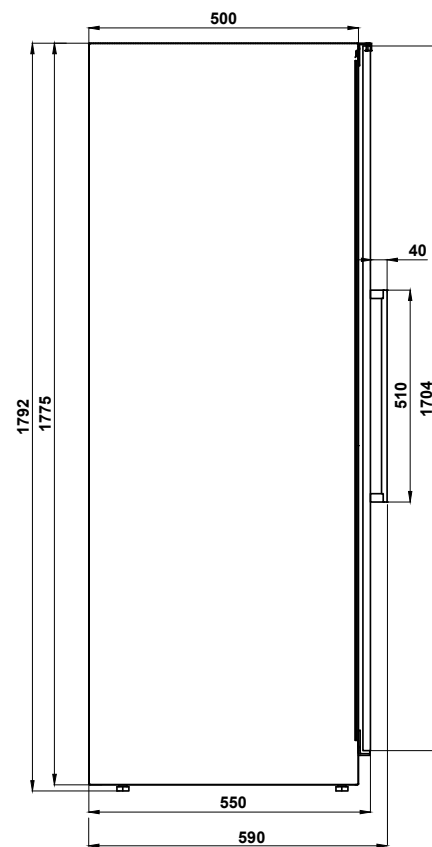
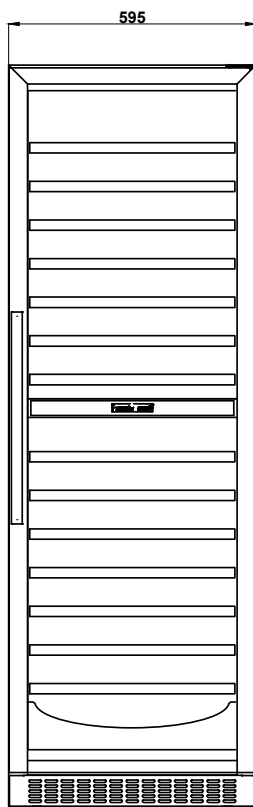

Medidas en / Dimensions in mm

MODELO LIBRE INSTALACIÓN
FREESTANDING MODEL



PVZL 180-165

Vinoteca libre instalación
Freestanding wine cooler

165
Ø75mm
300 mm

180 cm
Altura mueble
Size

2

Secciones de frío
Temperature zones



Compresor INVERTER
INVERTER compressor

Iluminación interior azul
Blue interior lighting



Guías telescópicas
Telescopic guides

Código Code	Referencia Product code	Acabados Finishing	Versión Version	Apertura Opens to
----------------	----------------------------	-----------------------	--------------------	----------------------

LUZ AZUL / BLUE LIGHT

010899	PVZL 180-165 CRR	Cristal Negro Black glass	Con tirador With handle	Der./Right
010900	PVZL 180-165 CRL			Izq./Left

Características / Features

Nº de botellas (tipo burdeos 0,75 litros)	Number of bottles (bordeaux type 0,75 ltrs)	165
Dimensiones (An x Al x F)	Dimensions (W x H x D)	595x1805x700 mm
Secciones de frío	Temperature zones	2
Temperatura operativa	Temperature range	+5°C a +20°C
Capacidad (litros)	Capacity (ltrs)	400
Consumo energético	Energy consumption	173 kWh/año-year
Nivel sonoro	Noise Level	44 db
Nº de cristales en la puerta	Number of glasses in the door	3
Filtro carbón activado	Activated carbon filter	Si/Yes
Guías telescópicas	Telescopic guides	Si/Yes

Opcional / Optional

010224 Kit cerradura vinoteca / With door lock



PVZL 180-165

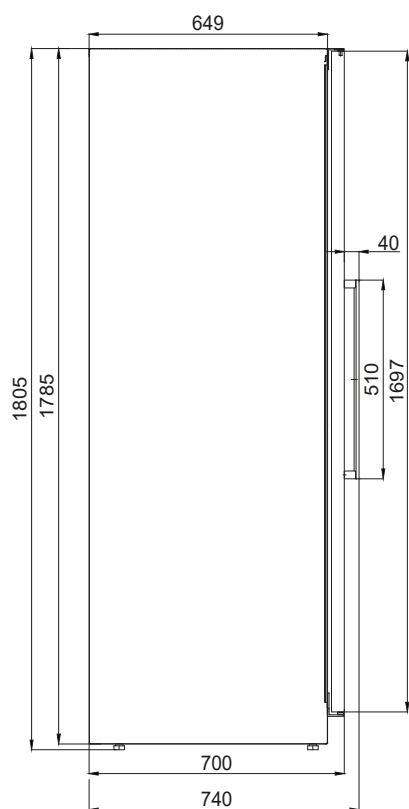

Fondo de 70 cm
Depth of 70 cm

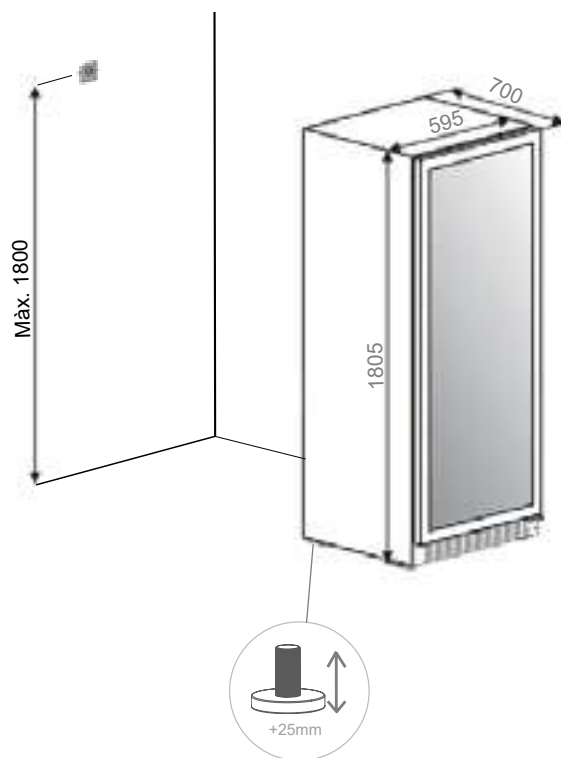

Patas regulables en altura de 10 a 25
Adjustable legs from 10 to 25

Medidas en / Dimensions in mm



Vinotecas

Mueble Alto

Wine coolers
Built-in





PVMC 15-5

Vinoteca Cajón
Wine cooler drawer



15 cm

Altura mueble
Size (Height)

1

Sección de frío
Temperature zone



Compresor INVERTER
INVERTER compressor

Iluminación interior **Multicolor**
3 intensidades
Multicolour interior Lighting
3 intensity levels



Código Code	Referencia Product code	Acabados Finishing	Versión Version
010854	PVMC 15-5 CR	Cristal Negro Black glass	Con Tirador With handle
010855	PVMC 15-5 PA	Panelable Decor panel	

Características / Features

Nº de botellas (tipo burdeos 0,75 litros)	Number of bottles (bordeaux type 0,75 ltrs)	5
Dimensiones (An x Al x F)	Dimensions (W x H x D)	595x141x557 mm
Secciones de frío	Temperature zones	1
Temperatura operativa	Temperature range	+5°C a +20°C
Capacidad (litros)	Capacity (ltrs)	13
Consumo energético	Energy consumption	88 kWh/año-year
Nivel sonoro	Noise Level	35 db
Iluminación Display	Display lighting	Blanca/White
Nº de cristales en la puerta	Num. of glasses in the door	3



PVMC 15-5

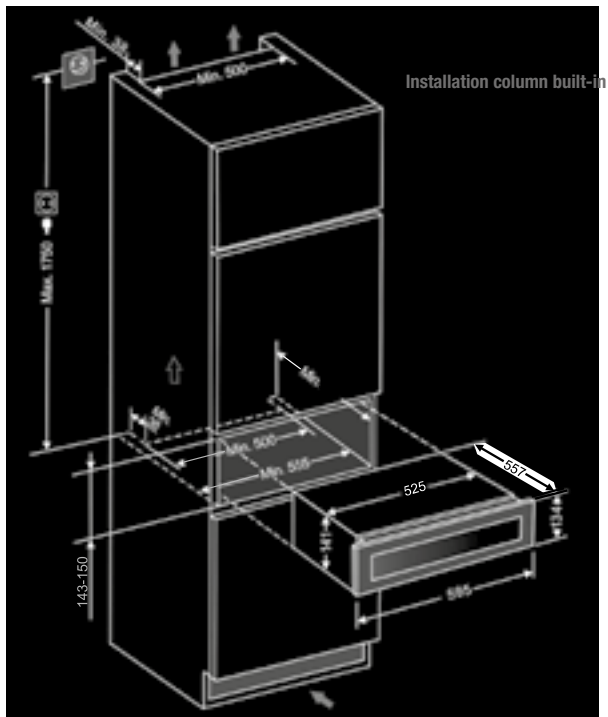

Instalación mueble bajo
Installation under counter

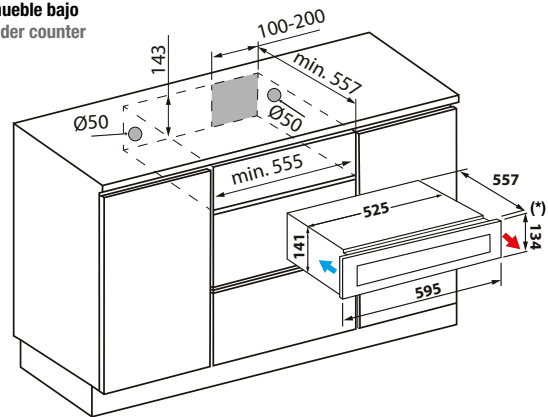

(*) **Puerta Cristal / Glass Door 4 mm**
Installation under counter 4 mm
Puerta Panelable, según material
Decor panel Door, depending on material

Medidas en / Dimensions in mm

(*) **Modelo panelable**
Decor panel door model

IMPORTANTE / IMPORTANT
Para favorecer la ventilación de la vinoteca, es obligatorio preparar el panel tal como indicamos.
To favour the ventilation of the wine cooler, it is compulsory to prepare the panel as indicated.

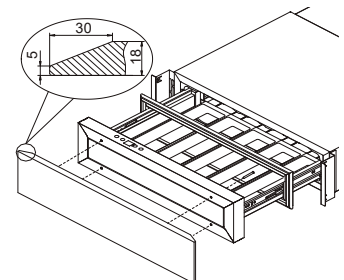
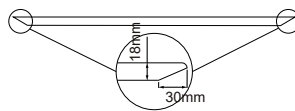
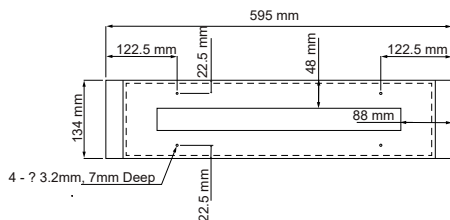

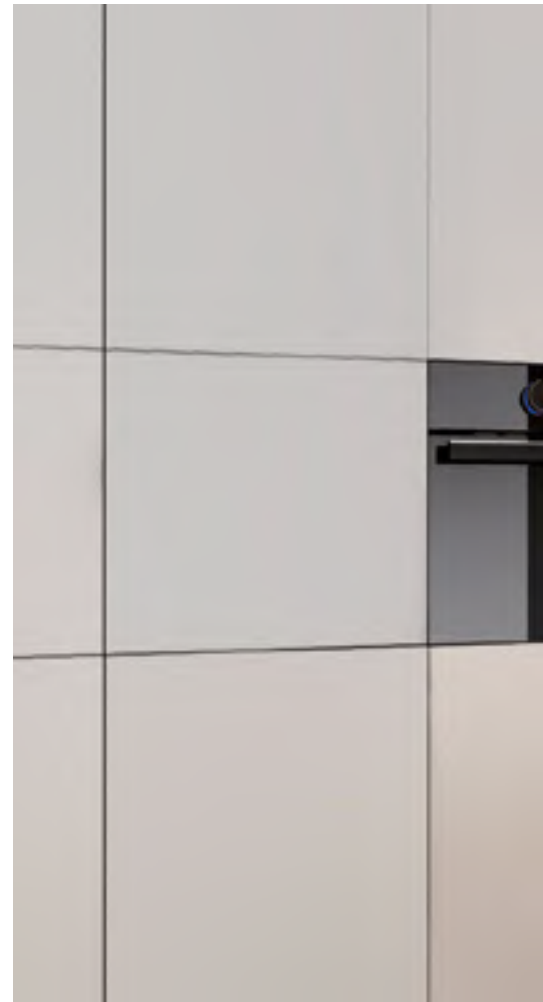

PVMMAV 45-16

Vinoteca mueble alto
Built-in wine cooler

16
Ø75mm
300 mm

45 cm

Altura mueble
Size (Height)

1

Sección de frío
Temperature zone



Compresor INVERTER
INVERTER compressor

Iluminación **Multicolor**
3 intensidades
Multicolour Lighting
3 intensity levels



Bisagra profesional
Professional German hinge
"Soft-Close"



Código Code	Referencia Product code	Acabados Finishing	Versión Version	Apertura Opens to
010707	PVMMAV 45-16 CRR	Cristal Negro Black glass	Con tirador With handle	Der./Right
010708	PVMMAV 45-16 CRL			Izq./Left
010741	PVMMAV 45-16 XR	Inox S/Steel		Der./Right
010740	PVMMAV 45-16 XL			Izq./Left
010709	PVMMAV 45-16 CRR	Cristal Negro Black glass	PUSH-TO-OPEN	Der./Right
010710	PVMMAV 45-16 CRL			Izq./Left
010743	PVMMAV 45-16 XR	Inox S/Steel		Der./Right
010742	PVMMAV 45-16 XL			Izq./Left

Características / Features

Nº de botellas (tipo burdeos 0,75 litros)	Number of bottles (bordeaux type 0,75 ltrs)	16
Dimensiones (An x Al x F)	Dimensions (W x H x D)	595x455x559 mm
Secciones de frío	Temperature zones	1
Temperatura operativa	Temperature range	+5°C a +20°C
Capacidad (litros)	Capacity (ltrs)	46
Consumo energético	Energy consumption	77 kWh/año-year
Nivel sonoro	Noise Level	35 db
Nº de cristales en la puerta	Num. of glasses in the door	3
Filtro carbón activado	Activated carbon filter	Si/Yes
Guías telescópicas	Telescopic guides	Si/Yes
Calentador	Heater	Si/Yes



Sistema de Ventilación Integrada
Built-in ventilation system

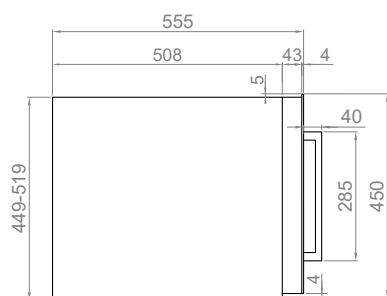

PVMAV 45-16

MUEBLE SIN VENTILACIÓN
CABINET WITHOUT VENTILATION

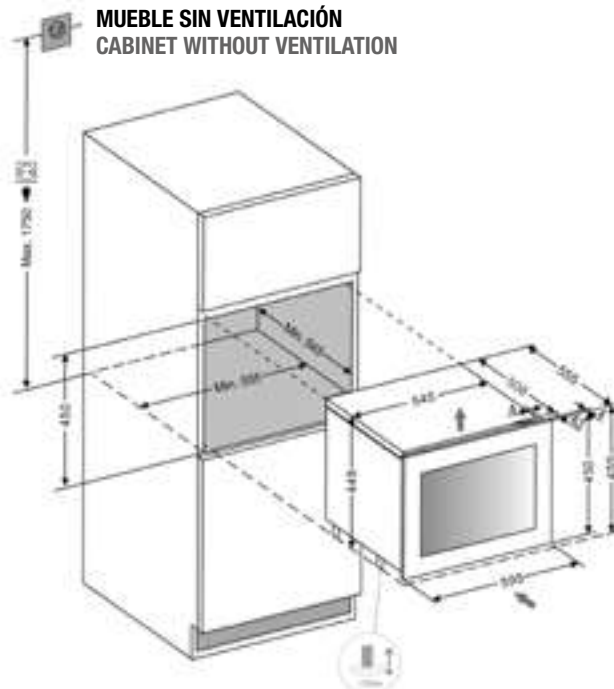

Patas regulables en altura de 10 a 70
Adjustable legs from 10 to 70

Medidas en / Dimensions in mm



PVMAV 60-23

Vinoteca mueble alto
Built-in wine cooler

23
Ø75mm
300 mm

60 cm

Altura mueble
Size (Height)

2

Secciones de frío
Temperature zones



Compresor INVERTER
INVERTER compressor

Illuminación **Multicolor**
3 intensidades
Multicolour Lighting
3 intensity levels



Bisagra profesional
Professional German hinge
"Soft-Close"

Código Code	Referencia Product code	Acabados Finishing	Versión Version	Apertura Opens to
010711	PVMAV 60-23 CRR	Cristal Negro Black glass	Con tirador With handle	Der./Right
010712	PVMAV 60-23 CRL			Izq./Left
010745	PVMAV 60-23 XR	Inox S/Steel		Der./Right
010744	PVMAV 60-23 XL			Izq./Left
010713	PVMAVP 60-23 CRR	Cristal Negro Black glass	PUSH-TO-OPEN	Der./Right
010714	PVMAVP 60-23 CRL			Izq./Left
010719	PVMAVP 60-23 XR	Inox S/Steel		Der./Right
010746	PVMAVP 60-23 XL			Izq./Left

Características / Features

Nº de botellas (tipo burdeos 0,75 litros)	Number of bottles (bordeaux type 0,75 ltrs)	23
Dimensiones (An x Al x F)	Dimensions (W x H x D)	595x595x559 mm
Secciones de frío	Temperature zones	2
Temperatura operativa	Temperature range	+5°C a +20°C
Capacidad (litros)	Capacity (ltrs)	63
Consumo energético	Energy consumption	99 Kwh/año-year
Nivel sonoro	Noise Level	35 db
Nº de cristales en la puerta	Num. of glasses in the door	3
Filtro carbón activado	Activated carbon filter	Si/Yes
Guías telescópicas	Telescopic guides	Si/Yes
Calentador	Heater	Si/Yes





Sistema de Ventilación Integrada
Built-in ventilation system

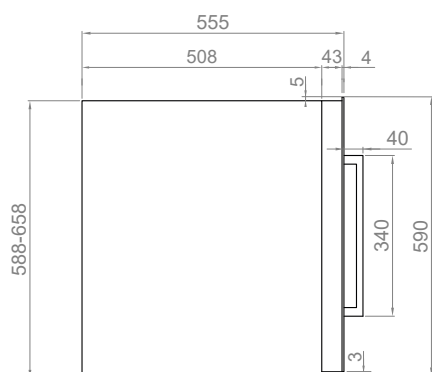

PVMAV 60-23

MUEBLE SIN VENTILACIÓN CABINET WITHOUT VENTILATION

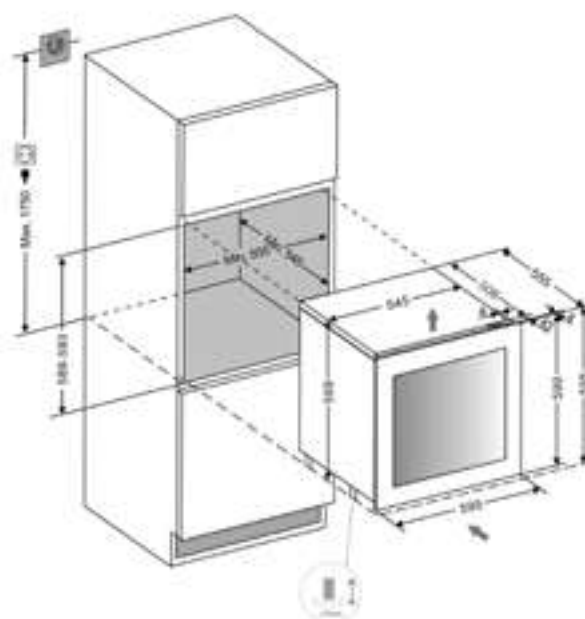

Patas regulables en altura de 10 a 70
Adjustable legs from 10 to 70

Medidas en / Dimensions in mm



New
Collection



PMAV 88-45

Vinoteca mueble alto
Built-in wine cooler

45
Ø75mm
300 mm

88 cm

Altura mueble
Size (Height)

2

Secciones de frío
Temperature zones



Compresor INVERTER
INVERTER compressor

Iluminación **Multicolor**
3 intensidades
Multicolour Lighting
3 intensity levels

A
↑
G



Bisagra profesional
Professional German hinge
"Soft-Close"

Código Code	Referencia Product code	Acabados Finishing	Versión Version	Apertura Opens to
010748	PMAV 88-45 CRR	Cristal Negro Black glass	Con tirador With handle	Der./Right
010747	PMAV 88-45 CRL			Izq./Left
010750	PMAV 88-45 XR	Inox S/Steel	PUSH-TO-OPEN	Der./Right
010749	PMAV 88-45 XL			Izq./Left
010752	PMAVP 88-45 CRR	Cristal Negro Black glass	PUSH-TO-OPEN	Der./Right
010751	PMAVP 88-45 CRL			Izq./Left
010754	PMAVP 88-45 XR	Inox S/Steel		Der./Right
010753	PMAVP 88-45 XL			Izq./Left

Características / Features

Nº de botellas (tipo burdeos 0,75 litros)	Number of bottles (bordeaux type 0,75 ltrs)	45
Dimensiones (An x Al x F)	Dimensions (W x H x D)	595x885x559 mm
Secciones de frío	Temperature zones	2
Temperatura operativa	Temperature range	+5°C a +20°C
Capacidad (litros)	Capacity (ltrs)	116
Consumo energético	Energy consumption	99 kWh/año-year
Nivel sonoro	Noise Level	36 db
Nº de cristales en la puerta	Num. of glasses in the door	3
Filtro carbón activado	Activated carbon filter	Si/Yes
Guías telescópicas	Telescopic guides	Si/Yes
Calefactor	Heater	Si/Yes





Sistema de Ventilación Integrada
Built-in ventilation system

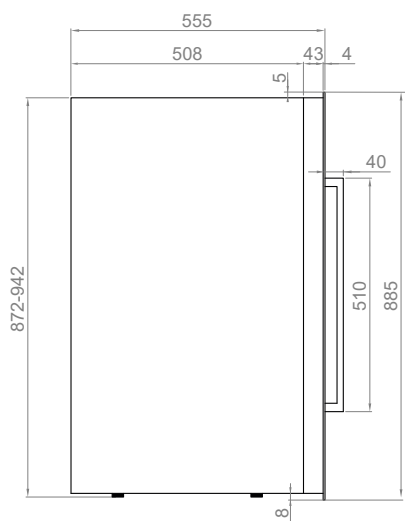

PVMAV 88-45

MUEBLE SIN VENTILACIÓN
CABINET WITHOUT VENTILATION

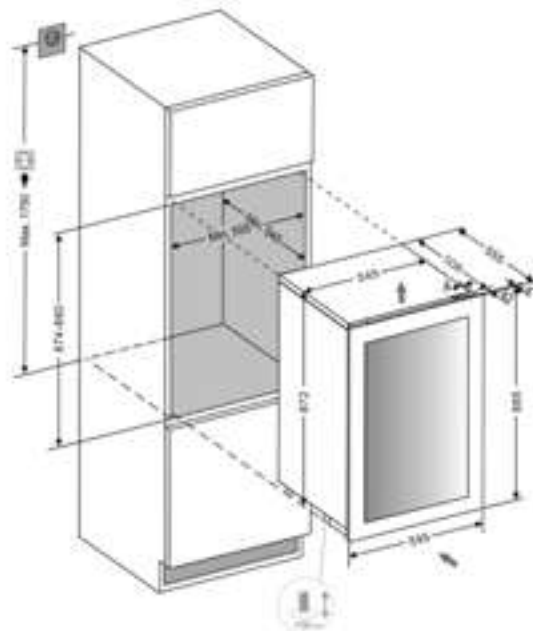

Patas regulables en altura de 10 a 50
Adjustable legs from 10 to 50

Medidas en / Dimensions in mm

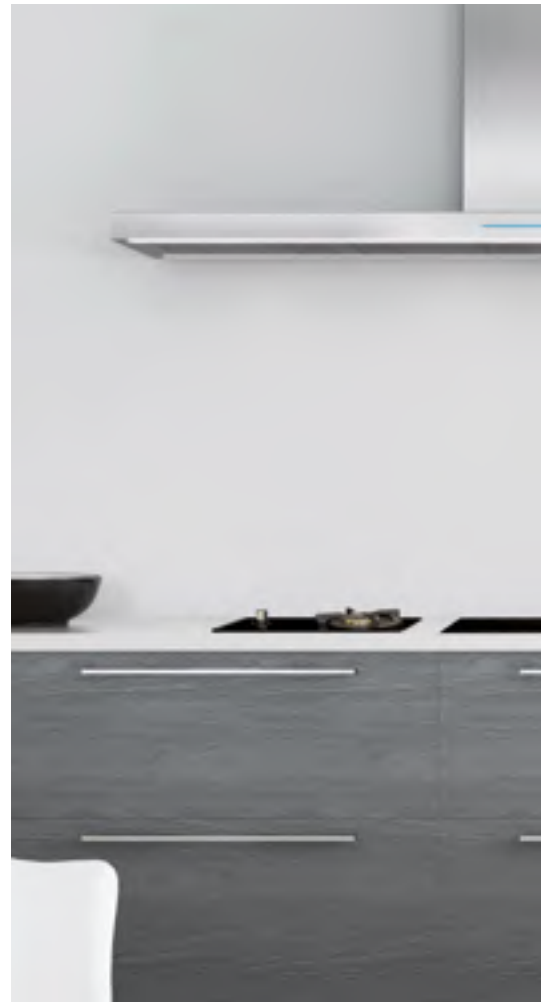

PMAV 124-65

Vinoteca mueble alto
Built-in wine cooler

65
Ø75mm
300 mm

124 cm
Altura mueble
Size (Height)

2

Secciones de frío
Temperature zones



Compresor INVERTER
INVERTER compressor

Iluminación **Multicolor**
3 intensidades
Multicolour Lighting
3 intensity levels



Bisagra profesional
Professional German hinge
"Soft-Close"



Código Code	Referencia Product code	Acabados Finishing	Versión Version	Apertura Opens to
010756	PMAV 124-65 CRR	Cristal Negro Black glass	Con tirador With handle	Der./Right
010755	PMAV 124-65 CRL			Izq./Left
010758	PMAV 124-65 XR	Inox S/Steel		Der./Right
101757	PMAV 124-65 XL			Izq./Left
010760	PMAVP 124-65 CRR	Cristal Negro Black glass	PUSH-TO-OPEN	Der./Right
010759	PMAVP 124-65 CRL			Izq./Left
010762	PMAVP 124-65 XR	Inox S/Steel		Der./Right
010761	PMAVP 124-65 XL			Izq./Left

Características / Features

Nº de botellas (tipo burdeos 0,75 litros)	Number of bottles (bordeaux type 0,75 ltrs)	65
Dimensiones (An x Al x F)	Dimensions (W x H x D)	595x1234x559 mm
Secciones de frío	Temperature zones	2
Temperatura operativa	Temperature range	+5°C a +20°C
Capacidad (litros)	Capacity (ltrs)	182
Consumo energético	Energy consumption	151 kWh/año-year
Nivel sonoro	Noise Level	36 db
Nº de cristales en la puerta	Num. of glasses in the door	3
Filtro carbón activado	Activated carbon filter	Si/Yes
Guías telescópicas	Telescopic guides	Si/Yes
Calentador	Heater	Si/Yes



Sistema de Ventilación Integrada
Built-in ventilation system

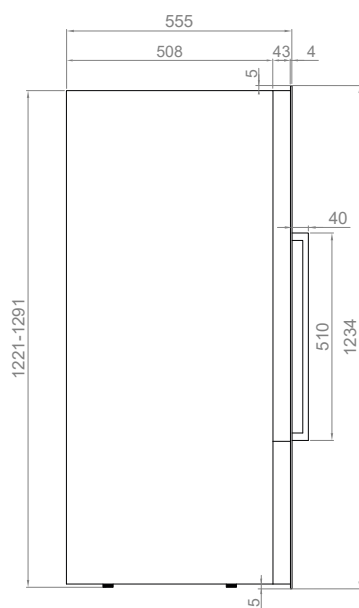

PVMAV 124-65

MUEBLE SIN VENTILACIÓN
CABINET WITHOUT VENTILATION

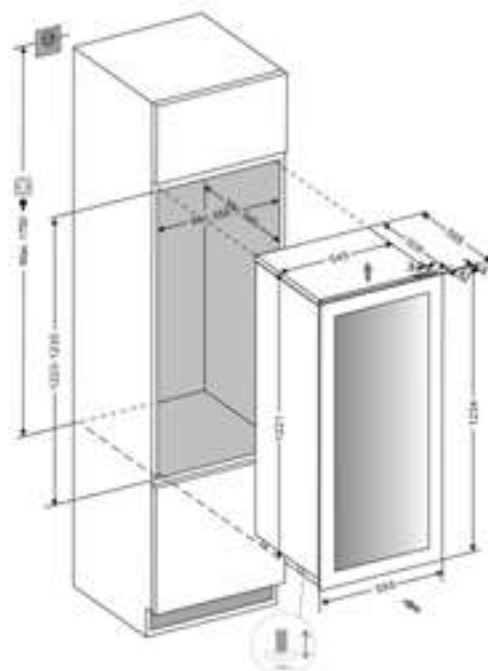

Patas regulables en altura de 10 a 50
Adjustable legs from 10 to 50

Medidas en / Dimensions in mm



PVMAV 178-101

Vinoteca mueble alto
Built-in wine cooler



178 cm
Altura mueble
Size (Height)

2

Secciones de frío
Temperature zones



Compresor INVERTER
INVERTER compressor

Iluminación **Multicolor**
3 intensidades
Multicolour Lighting
3 intensity levels



Bisagra profesional
Professional German hinge
"Soft-Close"



Código Code	Referencia Product code	Acabados Finishing	Versión Version	Apertura Opens to
010764	PVMAV 178-101 CRR	Cristal Negro Black glass	Con tirador With handle	Der./Right
010763	PVMAV 178-101 CRL			Izq./Left
010766	PVMAV 178-101 XR	Inox S/Steel		Der./Right
010765	PVMAV 178-101 XL			Izq./Left
010768	PVMAMP 178-101 CRR	Cristal Negro Black glass	PUSH-TO-OPEN	Der./Right
010767	PVMAMP 178-101 CRL			Izq./Left
010770	PVMAMP 178-101 XR	Inox S/Steel		Der./Right
010769	PVMAMP 178-101 XL			Izq./Left

Características / Features

Nº de botellas (tipo burdeos 0,75 litros)	Number of bottles (bordeaux type 0,75 ltrs)	101
Dimensiones (An x Al x F)	Dimensions (W x H x D)	595x1784x559 mm
Secciones de frío	Temperature zones	2
Temperatura operativa	Temperature range	+5°C a +20°C
Capacidad (litros)	Capacity (ltrs)	285
Consumo energético	Energy consumption	185 kWh/año-year
Nivel sonoro	Noise Level	36 db
Nº de cristales en la puerta	Num. of glasses in the door	3
Filtro carbón activado	Activated carbon filter	Si/Yes
Guías telescópicas	Telescopic guides	Si/Yes
Calefactor	Heater	Si/Yes



Sistema de Ventilación Integrada
Built-in ventilation system

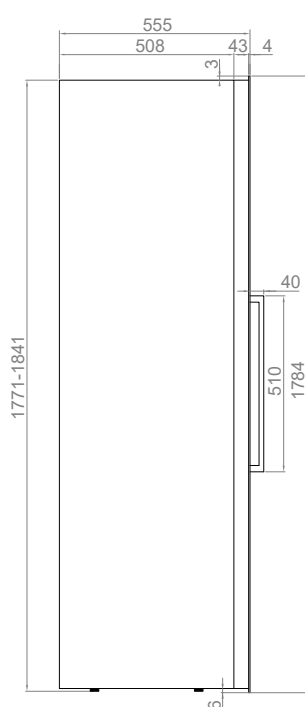

PVMAV 178-101

MUEBLE SIN VENTILACIÓN
CABINET WITHOUT VENTILATION

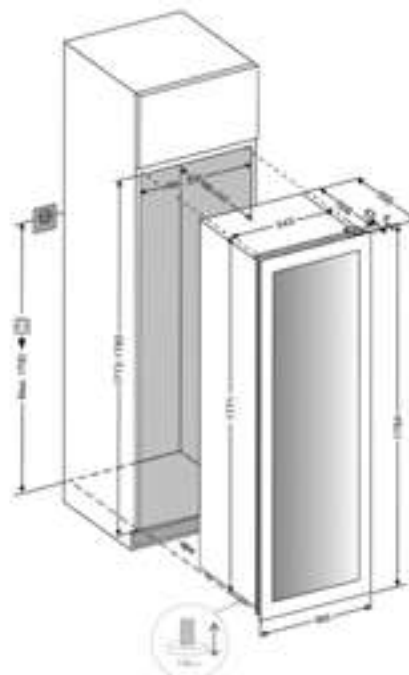

Patas regulables en altura de 10 a 50
Adjustable legs from 10 to 50

Medidas en / Dimensions in mm



Vinotecas

Panelables

Wine coolers
Built-in for
overlay decor panel







PVMBP 60-44 PA

Vinoteca PANELABLE bajo encimera

Under counter wine cooler for overlay decor panel door



60 cm
Anchura mueble
Size (Width)

2
Secciones de frío
Temperature zones



Iluminación **Multicolor**
3 intensidades
Multicolour Lighting
3 intensity levels



Bisagra profesional
Professional German hinge
"Soft-Close"

Código Code	Referencia Product code	Versión Version	Apertura Opens to
010772	PVMBP 60-44 PAR	PUSH-TO-OPEN	Der./Right
010771	PVMBP 60-44 PAL		Izq./Left

Características / Features

Nº de botellas (tipo burdeos 0,75 litros)	Number of bottles (bordeaux type 0,75 ltrs)	44
Dimensiones (An x Al x F)	Dimensions (W x H x D)	595x880x556 mm
Secciones de frío	Temperature zones	2
Temperatura operativa	Temperature range	+5°C a +20°C
Capacidad (litros)	Capacity (ltrs)	116
Consumo energético	Energy consumption	104 KwH/año-year
Nivel sonoro	Noise Level	35 db
Nº de cristales en la puerta	Num. of glasses in the door	3
Filtro carbón activado	Activated carbon filter	Si/Yes
Guías telescópicas	Telescopic guides	Si/Yes
Calentador	Heater	Si / Yes
Peso máximo del panel	Maximum panel door weight	10 kg



Altura de la puerta
Door height

Dimensiones panel
Panel dimensions

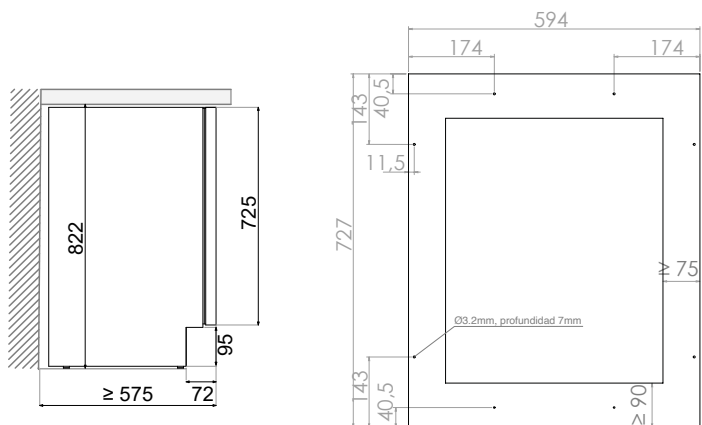

PVMBP 60-44 PA

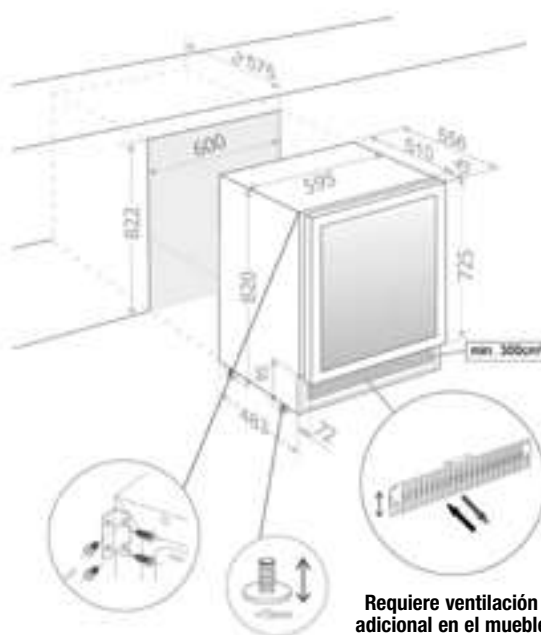

Patas regulables en altura de 10 a 70
Adjustable legs from 10 to 70

Requiere ventilación
adicional en el mueble
Requires additional cabinet
ventilation

Medidas en / Dimensions in mm



PVMBP HD 60-52 PA

Vinoteca PANELABLE bajo encimera
Under counter wine cooler for overlay decor panel door



60 cm
Anchura mueble
Size (Width)

2
Secciones de frío
Temperature zones



Iluminación **Multicolor**
3 intensidades
Multicolour Lighting
3 intensity levels



Bisagra profesional
Professional German hinge
"Soft-Close"

Código Code	Referencia Product code	Versión Version	Apertura Opens to
010739	PVMBP HD 60-52 PAR	PUSH-TO-OPEN	Der./Right
010738	PVMBP HD 60-52 PAL		Izq./Left

Características / Features

Nº de botellas (tipo burdeos 0,75 litros)	Number of bottles (bordeaux type 0,75 ltrs)	52
Dimensiones (An x Al x F)	Dimensions (W x H x D)	595x880x556 mm
Secciones de frío	Temperature zones	2
Temperatura operativa	Temperature range	+5°C a +20°C
Capacidad (litros)	Capacity (ltrs)	130
Consumo energético	Energy consumption	133 KwH/año-year
Nivel sonoro	Noise Level	35 db
Nº de cristales en la puerta	Num. of glasses in the door	3
Filtro carbón activado	Activated carbon filter	Si/Yes
Guías telescópicas	Telescopic guides	Si/Yes
Calefactor	Heater	Si / Yes
Peso máximo del panel	Maximum panel door weight	10 kg



PVMBP HD 60-52 PA



Altura de la puerta
Door height

Dimensiones panel
Panel dimensions

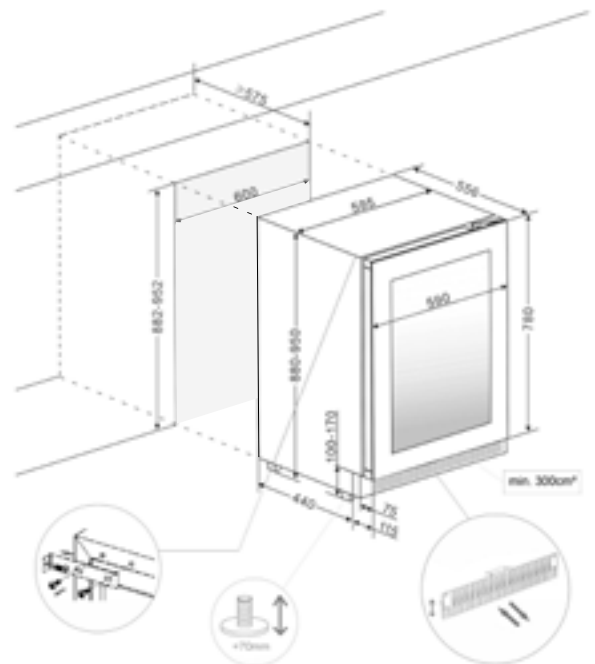
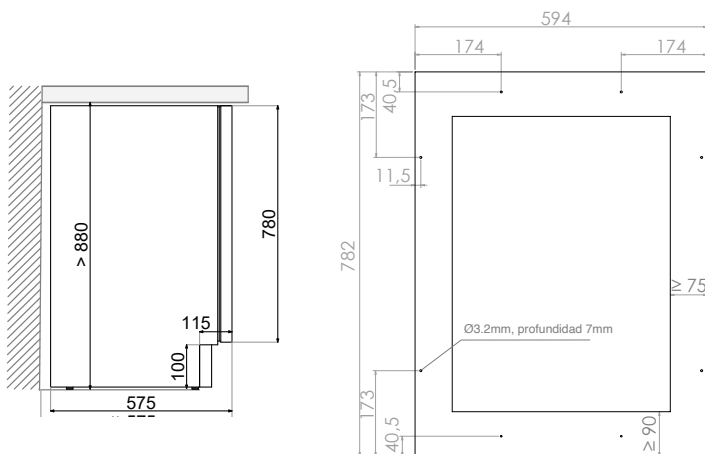

Patas regulables en altura de 10 a 70
Adjustable legs from 10 to 70

**Requiere ventilación
adicional en el mueble**
Requires additional cabinet
ventilation

Medidas en / Dimensions in mm



PVMA 45-16 PA

Vinoteca **PANELABLE** mueble columna
Built-in wine cooler for overlay decor panel door

16
Ø75mm
300 mm

45 cm

Altura mueble
Size (Height)

1

Sección de frío
Temperature zone



Compresor INVERTER
INVERTER compressor

Iluminación **Multicolor**
3 intensidades
Multicolour Lighting
3 intensity levels



Bisagra profesional
Professional German hinge
"Soft-Close"

Código Code	Referencia Product code	Versión Version	Apertura Opens to
010774	PVMA 45-16 PAR	Con tirador With handle	Der./Right
010773	PVMA 45-16 PAL		Izq./Left
010776	PVMAP 45-16 PAR	PUSH-TO-OPEN	Der./Right
010775	PVMAP 45-16 PAL		Izq./Left

Características / Features

Nº de botellas (tipo burdeos 0,75 litros)	Number of bottles (bordeaux type 0,75 ltrs)	16
Dimensiones (An x Al x F)	Dimensions (W x H x D)	595x455x559 mm
Secciones de frío	Temperature zones	1
Temperatura operativa	Temperature range	+5°C a +20°C
Capacidad (litros)	Capacity (ltrs)	46
Consumo energético	Energy consumption	77 kWh/año-year
Nivel sonoro	Noise Level	35 db
Nº de cristales en la puerta	Num. of glasses in the door	3
Filtro carbón activado	Activated carbon filter	Si/Yes
Guías telescópicas	Telescopic guides	Si/Yes
Calefactor	Heater	Si / Yes
Peso máximo del panel	Maximum panel door weight	10 kg



PVMA 45-16 PA

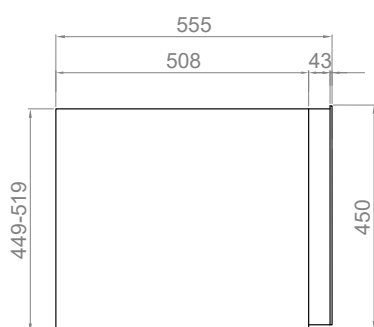

Dimensiones panel
Panel dimensions

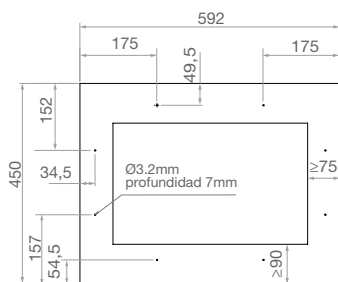

Requiere ventilación adicional en el mueble
Requires additional cabinet ventilation

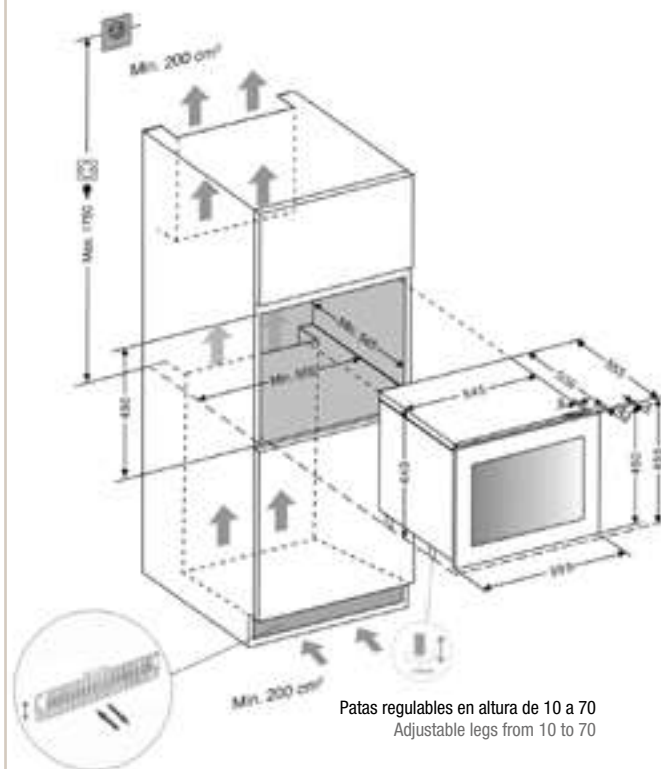

Requiere ventilación en zócalo
Requires additional plinth ventilation

Medidas en / Dimensions in mm



PVMA 60-23 PA

Vinoteca **PANELABLE** mueble columna
Built-in wine cooler for overlay decor panel door

23
Ø75mm
300 mm

60 cm

Altura mueble
Size (Height)

2

Secciones de frío
Temperature zones



Compresor INVERTER
INVERTER compressor

Iluminación **Multicolor**
3 intensidades
Multicolour Lighting
3 intensity levels



Bisagra profesional
Professional German hinge
"Soft-Close"

Código Code	Referencia Product code	Versión Version	Apertura Opens to
010778	PVMA 60-23 PAR	Con tirador With handle	Der./Right
010777	PVMA 60-23 PAL		Izq./Left
010780	PVMAP 60-23 PAR	PUSH-TO-OPEN	Der./Right
010779	PVMAP 60-23 PAL		Izq./Left

Características / Features

Nº de botellas (tipo burdeos 0,75 litros)	Number of bottles (bordeaux type 0,75 ltrs)	23
Dimensiones (An x Al x F) mm	Dimensions (W x H x D)	595x595x559 mm
Secciones de frío	Temperature zones	2
Temperatura operativa	Temperature range	+5°C a +20°C
Capacidad (litros)	Capacity (ltrs)	63
Consumo energético	Energy consumption	99 kWh/año-year
Nivel sonoro	Noise Level	35 db
Nº de cristales en la puerta	Num. of glasses in the door	3
Filtro carbón activado	Activated carbon filter	Si/Yes
Guías telescópicas	Telescopic guides	Si/Yes
Peso máximo del panel	Maximum panel door weight	10 kg



PVMA 60-23 PA

Dimensiones panel
Panel dimensions

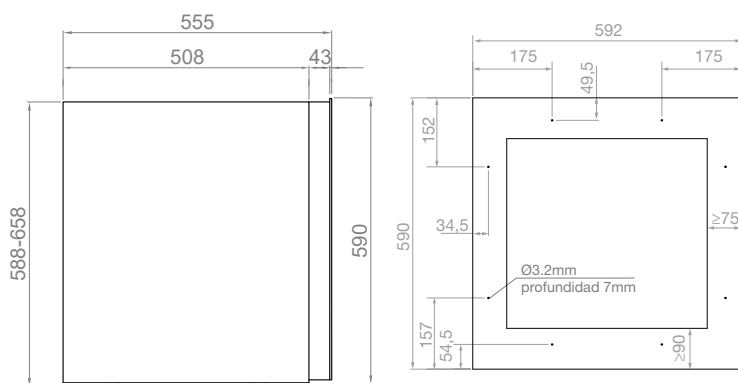

Requiere ventilación adicional en el mueble
Requires additional cabinet ventilation

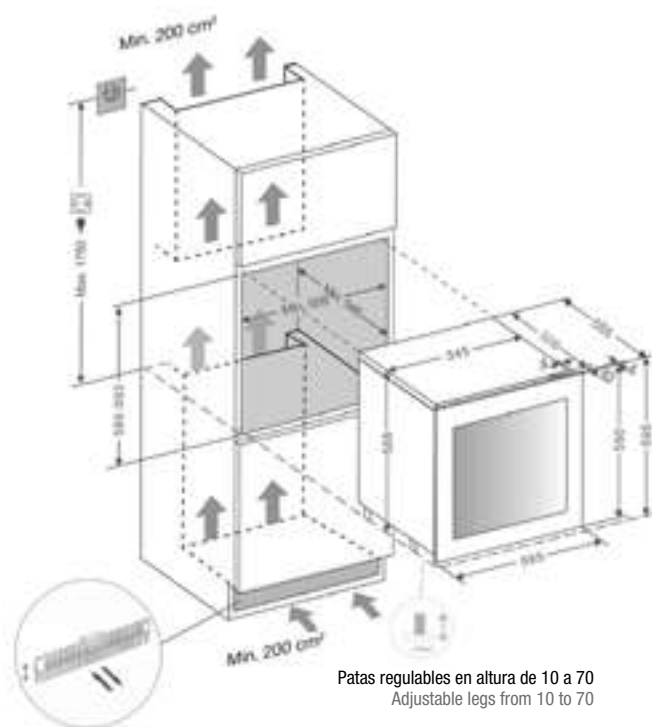

Requiere ventilación en zócalo
Requires additional plinth ventilation

Medidas en / Dimensions in mm



PVMA 88-45 PA

Vinoteca PANELABLE mueble columna
Built-in wine cooler for overlay decor panel door

45
Ø75mm
300 mm

88 cm

Altura mueble
Size (Height)

2

Secciones de frío
Temperature zones



Compresor INVERTER
INVERTER compressor

Iluminación **Multicolor**
3 intensidades
Multicolour Lighting
3 intensity levels



Bisagra profesional
Professional German hinge
"Soft-Close"

Código Code	Referencia Product code	Versión Version	Apertura Opens to
010782	PVMA 88-45 PAR	Con tirador With handle	Der./Right Izq./Left
010781	PVMA 88-45 PAL		Izq./Left Der./Right
010784	PVMAP 88-45 PAR	PUSH-TO-OPEN	Der./Right
010783	PVMAP 88-45 PAL		Izq./Left

Características / Features

Nº de botellas (tipo burdeos 0,75 litros)	Number of bottles (bordeaux type 0,75 ltrs)	45
Dimensiones (An x Al x F)	Dimensions (W x H x D)	595x885x559 mm
Secciones de frío	Temperature zones	2
Temperatura operativa	Temperature range	+5°C a +20°C
Capacidad (litros)	Capacity (ltrs)	128
Consumo energético	Energy consumption	128 kWh/año-year
Nivel sonoro	Noise Level	36 db
Nº de cristales en la puerta	Num. of glasses in the door	3
Filtro carbón activado	Activated carbon filter	Si/Yes
Guías telescópicas	Telescopic guides	Si/Yes
Peso máximo del panel	Maximum panel door weight	10 kg



PVMA 88-45 PA

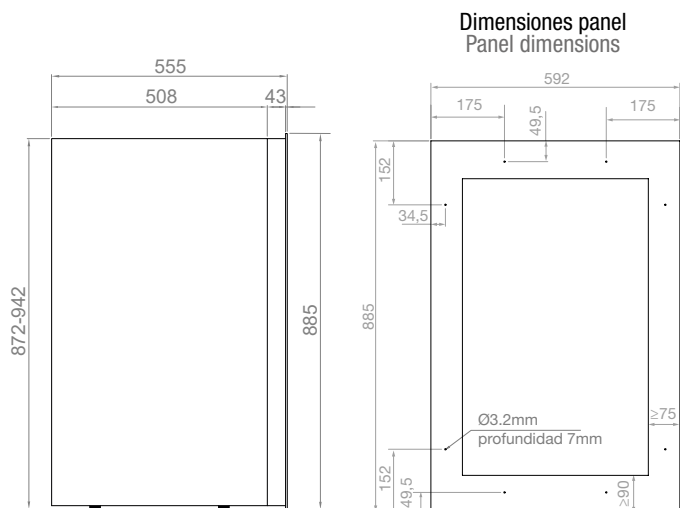

Requiere ventilación adicional en el mueble
Requires additional cabinet ventilation

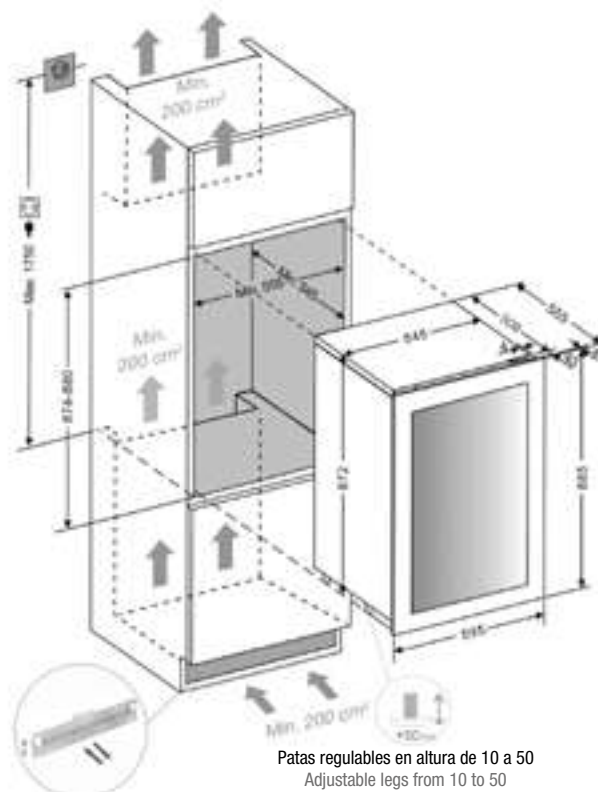

Requiere ventilación en zócalo
Requires additional plinth ventilation

Medidas en / Dimensions in mm



PVMA 124-65 PA

Vinoteca PANELABLE mueble columna
Built-in wine cooler for overlay decor panel door



124 cm
Altura mueble
Size (Height)

2

Secciones de frío
Temperature zones



Compresor INVERTER
INVERTER compressor

Iluminación **Multicolor**
3 intensidades
Multicolour Lighting
3 intensity levels



Bisagra profesional
Professional German hinge
"Soft-Close"

Código Code	Referencia Product code	Versión Version	Apertura Opens to
010786	PVMA 124-65 PAR	Con tirador With handle	Der./Right
010785	PVMA 124-65 PAL		Izq./Left
010788	PVMAP 124-65 PAR	PUSH-TO-OPEN	Der./Right
010787	PVMAP 124-65 PAL		Izq./Left

Características / Features

Nº de botellas (tipo burdeos 0,75 litros)	Number of bottles (bordeaux type 0,75 ltrs)	65
Dimensiones (An x Al x F)	Dimensions (W x H x D)	595x1234x559 mm
Secciones de frío	Temperature zones	2
Temperatura operativa	Temperature range	+5°C a +20°C
Capacidad (litros)	Capacity (ltrs)	182
Consumo energético	Energy consumption	151 KwH/año-year
Nivel sonoro	Noise Level	36 db
Compresor con sistema inverter	Compressor with inverter system	Si / Yes
Nº de cristales en la puerta	Num. of glasses in the door	3
Filtro carbón activado	Activated carbon filter	Si/Yes
Guías telescópicas	Telescopic guides	Si/Yes
Peso máximo del panel	Maximum panel door weight	10 kg



PVMA 124-65 PA

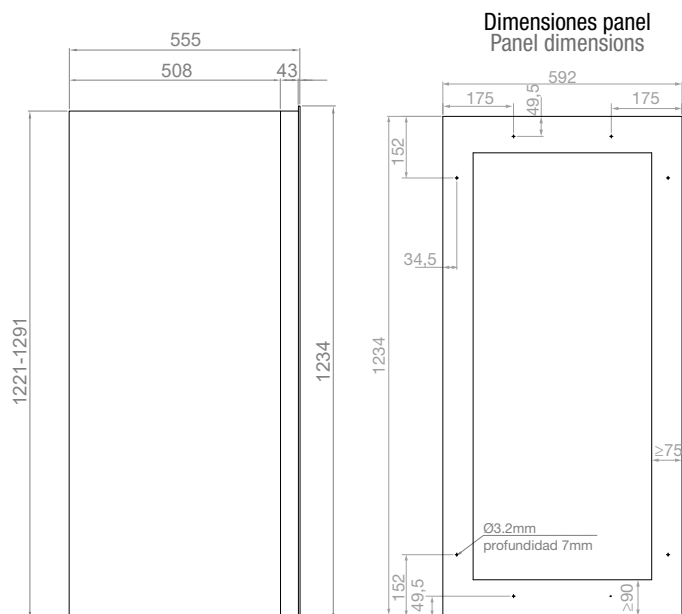

Requiere ventilación adicional en el mueble
Requires additional cabinet ventilation

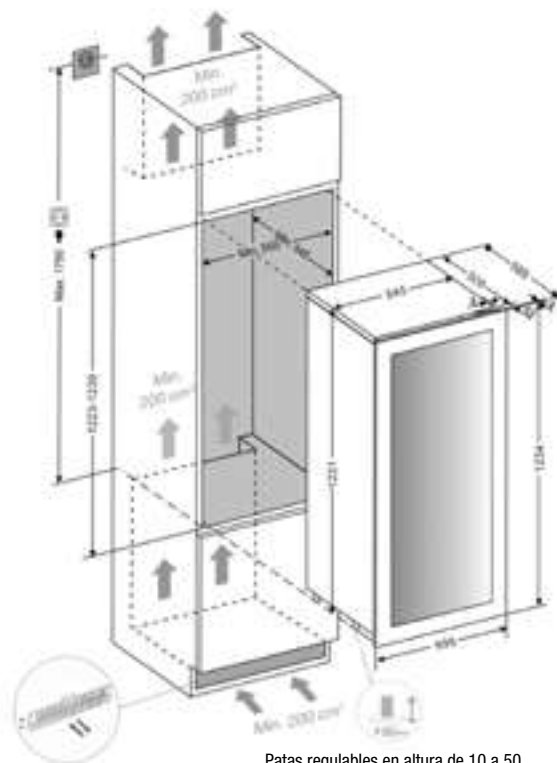

Requiere ventilación en zócalo
Requires additional plinth ventilation

Patas regulables en altura de 10 a 50
Adjustable legs from 10 to 50

Medidas en / Dimensions in mm



PVMA 178-101 PA

Vinoteca PANELABLE mueble columna
Built-in wine cooler for overlay decor panel door



178 cm
Altura mueble
Size (Height)

2

Secciones de frío
Temperature zones



Compresor INVERTER
INVERTER compressor

Iluminación **Multicolor**
3 intensidades
Multicolour Lighting
3 intensity levels

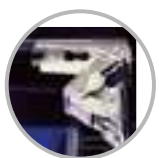

Bisagra profesional
Professional German hinge
"Soft-Close"

Código Code	Referencia Product code	Versión Version	Apertura Opens to
010790	PVMA 178-101 PAR	Con tirador With handle	Der./Right
010789	PVMA 178-101 PAL		Izq./Left
010792	PVMAP 178-101 PAR	PUSH-TO-OPEN	Der./Right
010791	PVMAP 178-101 PAL		Izq./Left

Características / Features

Nº de botellas (tipo burdeos 0,75 litros)	Number of bottles (bordeaux type 0,75 ltrs)	101
Dimensiones (An x Al x F)	Dimensions (W x H x D)	595x1784x559 mm
Secciones de frío	Temperature zones	2
Temperatura operativa	Temperature range	+5°C a +20°C
Capacidad (litros)	Capacity (ltrs)	285
Consumo energético	Energy consumption	185 kWh/año-year
Nivel sonoro	Noise Level	36 db
Compresor con sistema inverter	Compressor with inverter system	Si / Yes
Nº de cristales en la puerta	Num. of glasses in the door	3
Filtro carbón activado	Activated carbon filter	Si/Yes
Guías telescópicas	Telescopic guides	Si/Yes
Peso máximo del panel	Maximum panel door weight	10 kg



PVMA 178-101 PA

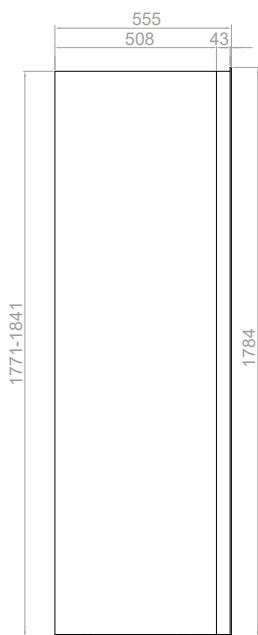

Medida calculada con base de mueble de 19 mm de grosor
Dimensions calculated based on a 19 mm cabinet

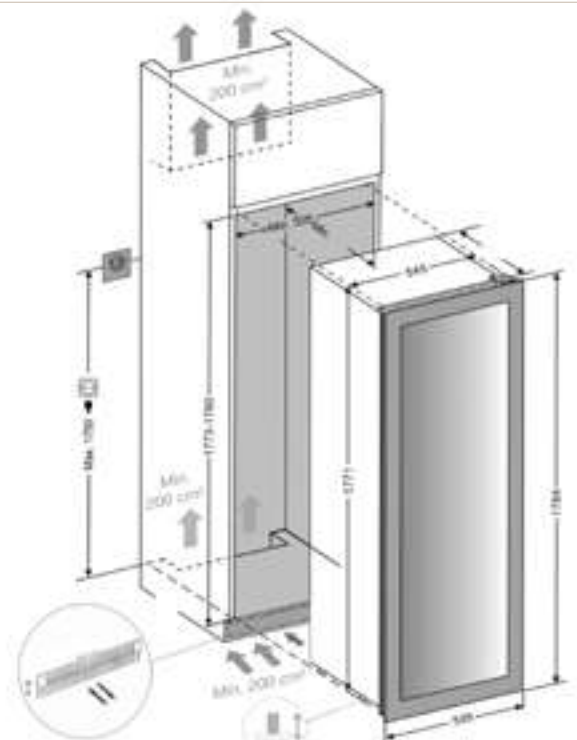
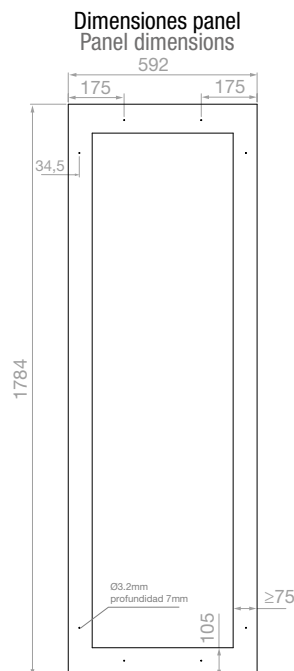

Requiere ventilación en zócalo
Requires additional plinth ventilation

Patas regulables en altura de 10 a 50
Adjustable legs from 10 to 50

Medidas en / Dimensions in mm



Requiere ventilación adicional en el mueble
Requires additional cabinet ventilation



PBE 89-66

Bodega de envejecimiento bajo encimera
Under counter Aging wine cellar

<p>66 300 mm Ø75mm</p>	<p>89 cm Altura mueble Size (Height)</p>	<p>1 Sección de frío Temperature zone</p>	<p>Display digital LED LED Digital display</p>	<p>Higrómetro incorporado Incorporated Hygrometers</p>	<p>Iluminación Multicolor 3 intensidades Multicolour Lighting 3 intensity levels</p>
--------------------------------	--	---	--	--	--



Código Code	Referencia Product code	Acabados Finishing	Versión Version	Apertura Opens to
010839	PBE 89-66 CRR	Cristal Negro Black glass	Con tirador With handle	Der./Right
010838	PBE 89-66 CRL			Izq./Left

Características / Features

Nº de botellas (tipo burdeos 0,75 litros)	Number of bottles (bordeaux type 0,75 ltrs)	66
Dimensiones (An x Al x F)	Dimensions (W x H x D)	595x890x575 mm
Secciones de frío	Temperature zones	1
Temperatura operativa	Temperature range	+5°C a +20°C
Capacidad (litros)	Capacity (ltrs)	128
Consumo energético	Energy consumption	76 kWh/año-year
Nivel sonoro	Noise Level	40 db
Filtro de carbón	Carbon filter	Si / Yes
Puerta totalmente opaca	Door totally opaque	Si / Yes

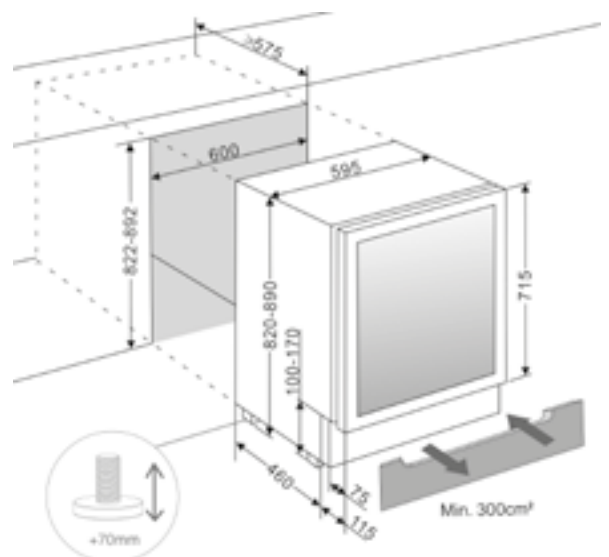

Patas regulables en altura de 10 a 70
Adjustable legs from 10 to 70

Medidas en / Dimensions in mm



PBE 182-190

Bodega de envejecimiento libre instalación
Freestanding Aging wine cellar

190



182 cm

Altura mueble
Size (Height)

1

Sección de frío
Temperature zone



Display digital LED
LED Digital display



Higrómetro incorporado
Incorporated Hygrometers

Iluminación Multicolor
3 intensidades
Multicolour Lighting
3 intensity levels



Código Code	Referencia Product code	Acabados Finishing	Versión Version	Apertura Opens to
010837	PBE 182-190 CRR	Cristal Negro Black glass	Con tirador With handle	Der./Right
010836	PBE 182-190 CRL			Izq./Left

Características / Product features

Nº de botellas (tipo burdeos 0,75 litros)	Number of bottles (bordeaux type 0,75 ltrs)	190
Dimensiones (An x Al x F)	Dimensions (W x H x D)	595x1820x575 mm
Secciones de frío	Temperature zones	1
Temperatura operativa	Temperature range	+5°C a +20°C
Capacidad (litros)	Capacity (ltrs)	335
Consumo energético	Energy consumption	144 kWh/año-year
Nivel sonoro	Noise Level	40 db
Filtro de carbón	Carbon filter	Si / Yes
Puerta totalmente opaca	Door totally opaque	Si / Yes
Zócalo de cristal incluido	Glass plinth included	Si / Yes

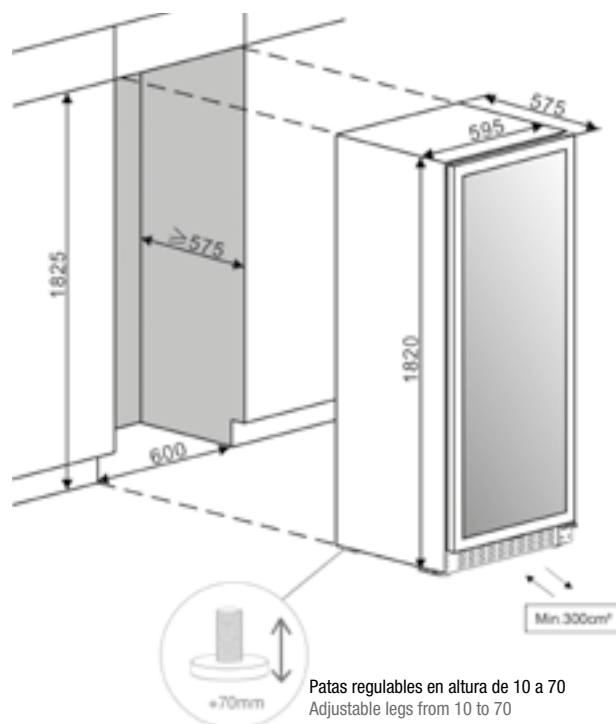

Medidas en / Dimensions in mm



A grayscale photograph of two decorative cooker hoods. The hoods are rectangular with a grid of small square vents. They are mounted on a wall, and the lighting creates soft shadows and highlights on their surfaces. The text is overlaid on the central part of the image.

**CAMPANAS
DECORATIVAS
DECORATIVE
COOKER HOODS
INFORMACIÓN
TÉCNICA
TECHNICAL
INFORMATION**

VERSIÓN MOTORES MOTOR VERSIONS	TIPO MOTOR MOTOR TYPE	Ø conducto duct (mm)	CAUDAL / AIRFLOW			POTENCIA SONORA SOUND POWER		POTENCIA MÁXIMA MAXIMUM POWER	PRESIÓN MÁXIMA MAXIMUM PRESSURE	Conducto máximo recomendado Max recom. ducting	Longitud de serie en cables conexión motor exterior Metros lineales linear meters
			Q MÍN.* m³/h	Q MAX.* (Intensive) m³/h	Q MAX. (Free 0Pa) m³/h	Lw MÍN.* dBA	Lw MAX.* dBA	W MAX. W	Pa		
INTERIORES (dentro de la campana) / INTERIOR (inside the hood)											
V.700	INT	150 / 120	199	382	560	49	60	140	260	4	-
V.730	INT	120	195	456	466	42	60	125	296	5	-
V.750	INT	125	218	483	590	45	66	150	455	6	-
V.830	INT	150 / 120	301	562	720	48	62	250	487	7	-
V.850	INT	150 (1)	307	690	738	48	60	265	604	8	-
V.950	INT	150	158	757	763	38	61	350	589	6	-
V.1350	INT/EXT *h	150	313	856	910	46	61	290	505	10	-
INTERIORES ECO (dentro de la campana) / INTERIOR ECO (inside the hood)											
V.930 ECO	INT	220x90	198	614	630	52	71	220	670	-	-
V.1130 ECO	INT	150	141	592	1015	38	59	85	530	8	-
V.1050 ECO SEC PLUS	INT	150	134	760	905	36	50	170	440	8	-
V.1250 ECO	INT	150	250	941	1080	38	58	230	490	10	-
V.1350 ECO	INT/EXT *h	150	250	970	1085	39	61	230	490	10	-
V.2200 ECO	INT	200	642	1604	2190	47	61	750	1030	15	-
INTERMEDIOS EXTERIORES / IN-LINE REMOTE MOTORS											
V.1200 TIPO 1	EXT	150	199	602	763	38	54	350	589	6 *a	7
V.2000 TIPO 1	EXT	200	293	807	1495	32	41	250	720	10 *b	7
INTERMEDIOS EXTERIORES ECO / ECO IN-LINE REMOTE MOTORS											
V1550 ECO TIPO 1 Y 2	EXT	150	198	767	1080	36	51	230	490	10 *c	6
V2450 ECO TIPO 2	EXT	200	430	1440	2335	39	59	168	498	12 *d	6
V2600 ECO TIPO 1 Y 2	EXT	200	642	1795	2190	45	59	750	1030	15 *e	12
V3000 ECO TIPO 2	EXT	200	645	2915	3450	44	61	660	960	18 *e	12
MURO ECO (Fachada) / ECO OUTDOORS WALL MOTOR											
V.1300 ECO	MUR	150	217	812	1290	42	56	168	990	6	6
TEJADO ECO (En tejado o chimenea exterior) / ECO OVER-THE-ROOF MOTORS											
V.2350 ECO	TEJ	200	410	1675	2335	44	55	168	498	12 *f	12
V.3300 ECO	TEJ	200	612	2880	3450	53	68	660	920	18 *g	18

*a. De campana a motor máx. 2m

*b. De campana a motor mín. 2m - máx. 6m

*c. De campana a motor máx. 4m

*d. De campana a motor mín. 4m - máx. 6m

*e. De campana a motor mín. 6m - máx. 12m

*f. De campana a motor mín. 4m - máx. 12m

*g. De campana a motor mín. 6m - máx. 18m

*h. Motor exterior disponible según modelo, consultar catálogo.

Limite el número de curvas en la canalización, ya que cada curva reduce la eficacia de la aspiración:

• En Ø150 mm un codo 90° = 1m lineal.

• En Ø200 mm un codo 90° = 2,5m lineal.

Ejemplo: Si se usan 2 codos de 90°, la longitud total de una canalización de 3m lineales Ø150mm (3+1+1), es de 5m.

Si se usan 2 codos de 90°, la longitud total de una canalización de 3m lineales Ø200mm (3+2,5+2,5), es de 8m.

Los valores indicados están realizados a partir de ensayos en condiciones de laboratorio. Dependiendo del modelo y características de cada campana podrían variar sensiblemente. Debido a las constantes mejoras que Pando realiza en sus productos, esta información está siempre actualizada en nuestra web (www.pando.es)

* UNE-EN 61591, UNE-EN 60704-2-13

(* El uso de la certificación y de la marca es exclusivo para los modelos marcados con este símbolo en su etiqueta identificativa. The use of the certification and the brand is exclusive for all models marked with this symbol in its identifying label.

(1) Ø150/120 SOLO en modelos indicados en el Catálogo / Ø150/120 ONLY on models listed in the Catalogue

*a. From hood to motor max. 2m

*b. From hood to motor mín. 2m - máx. 6m

*c. From hood to motor máx. 4m

*d. From hood to motor mín. 4m - máx. 6m

*e. From hood to motor mín. 6m - máx. 12m

*f. From hood to motor mín. 4m - máx. 12m

*g. From hood to motor mín. 6m - máx. 18m

Limit the number of bends along the ducting, since every bend reduces the effectiveness of the airflow capacity:

• In Ø150 mm a 90° curve = 1 m linear.

• In Ø200 mm a 90° curve = 2.5 m linear.

i.e. If you use 2 curves of 90°, the total effective length of a 3 m linear 150 Ø duct is 3+1+1=5 m.

If you use 2 curves of 90°, the total effective length of a 3 m linear 200 Ø duct is 3+2.5+2.5=8 m.

Given values are based on tests under laboratory conditions. They may slightly vary depending on the model and the features of each hood. Due to the constant improvements that made by Pando in their products, this information is always up to date on our website (www.pando.es)



(* Certificación de Producto SGS conforme a la norma UNE-EN 60335

Hay que recordar siempre que las campanas extractoras de humos son aparatos electrodomésticos que necesitan de una instalación previa de tubo conductor de humos y que posteriormente deben respetarse unas condiciones mínimas de colocación (altura y anchura de campana sobre la encimera de cocción), y por supuesto, las de seguridad. El no respetar estas condiciones, supondrá con toda seguridad, que la campana tenga un rendimiento deficiente y muchas veces nulo.

A continuación les describimos las condiciones mínimas de colocación de una campana:

Please remember that a cooker hood is a domestic appliance used for extracting all odours, smoke and grease particles produced while cooking in the kitchen. Possibly this hood will be connected to an existing trunking to outside. Also the minimum distances from the cooker top (height and width) must be maintained to achieve the proper safe and optimized hood performance. Failure to take these parameters into account will create a deficient, or even void, effectiveness of extraction. Before choosing your cooker hood you should evaluate your kitchen dimensions as well as the appliances involved. **Care should also be taken as to the correct connections to any reused existing ducts, as explained later.**

DIMENSIÓN DE LA CAMPANA

SIZE OF COOKER HOOD

Debe de ser igual o más grande que la placa de cocción para un funcionamiento óptimo.

Must be equal or larger than the hob for a proper working



Bien instalada
Correct



Mal instalada
Wrong



Imprescindible que la campana esté centrada sobre la zona de cocción

It is important that the cooker hood is installed centered above the hob

DISTANCIA ÓPTIMA

OPTIMUM DISTANCE

entre la campana y la placa de cocción
between cooker hood and cooktop

CAMPANAS DE PARED

WALL COOKER HOODS

Altura óptima
Optimum height

650 mm



CAMPANAS DE ISLA

ISLAND COOKER HOODS

Altura óptima
Optimum height

650 mm



CAMPANAS DE INTEGRACIÓN

INTEGRATED COOKER HOODS

Altura óptima
Optimum height

Induction
550 mm
Gas
650 mm



CAMPANAS DE TECHO

CEILING COOKER HOODS

Altura óptima
Optimum height

1400-1700 mm



A

MOTORES INTERIORES

INTERNAL MOTORS

V.700, V.730, V.750, V.830, V.850, V.950, V.1350
V.930 ECO, V.1130 ECO PLUS, V.1350 ECO
V.1050 ECO SEC System PLUS,
V.1250 ECO SEC y/and V.2200 ECO SEC



Motores instalados dentro del cuerpo de la campana.
Muchas de las versiones incorporan sistemas ECO eficientes y de gran rendimiento y bajo nivel sonoro.
El sistema V.1050 proporciona una reducción sonora de hasta un 20%.
V.1130 ECO PLUS consigue hasta un 57% más de caudal y mejora de presión en conducto.

Motors fitted inside the hood casing.
Many of the versions feature ECO efficient systems offering high performance at very low noise levels.
The V.1050 system offers up to 20% noise reduction
The V.1130 ECO PLUS achieves up to 57% higher flow and improved pressure in the pipe

B

MOTORES INTERMEDIOS EXTERIORES

EXTERNAL DUCT-IN-LINE MOTORS

V.1550 ECO, V.2450 ECO
V.2600 ECO y/and V.3000 ECO T2
V.1200 y/and V.2000S



Motores intermedios de colocación fuera del chasis de la campana. Pueden instalarse en falso techo o bajo cubierta. No pueden instalarse a la intemperie.
Gran capacidad de extracción sin ruido.

INCLUIDO

Las unidades con motorizaciones V.2450 y V.3000 Intermedio Exterior incorporan de serie 5 m de tubo de extracción de humos SEC System® de Ø203 mm interior y Ø253 mm exterior.

Duct-in-line remote motors fitted separately from the hood chassis.
They can be mounted on a false ceiling or under the roof. They cannot be installed outdoors. High extraction capacity and without noise.

INCLUDED

The models with the V.2450 and V.3000 duct-in-line remote motor comes with 5 m of S.E.C. fume extractor flue as standard System®, interior Ø 203 mm and exterior Ø 253.

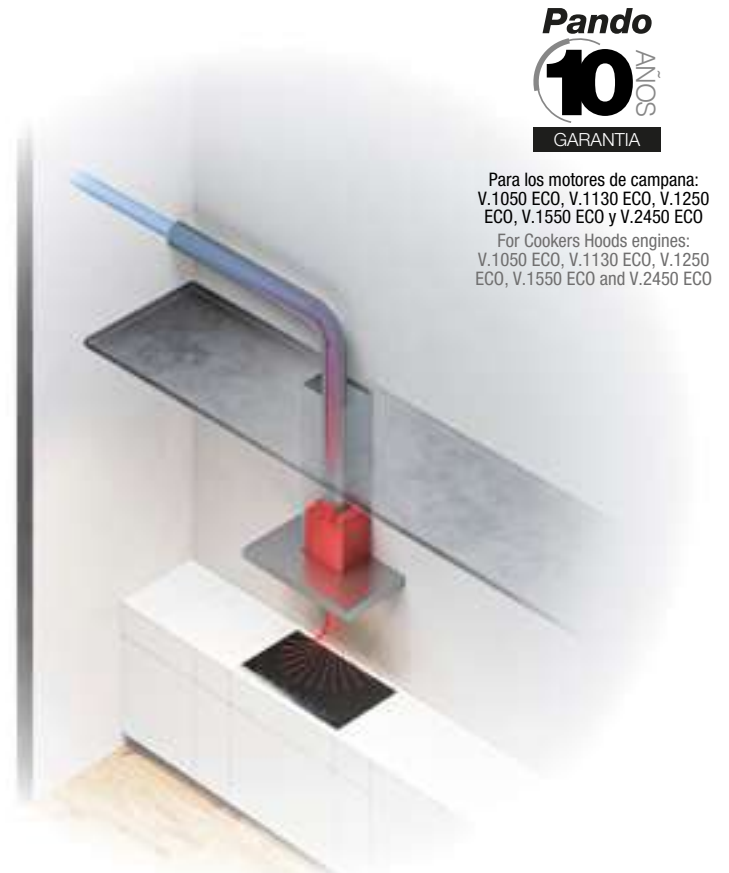

Para los motores de campana:
V.1050 ECO, V.1130 ECO, V.1250
ECO, V.1550 ECO y V.2450 ECO

For Cookers Hoods engines:
V.1050 ECO, V.1130 ECO, V.1250
ECO, V.1550 ECO and V.2450 ECO

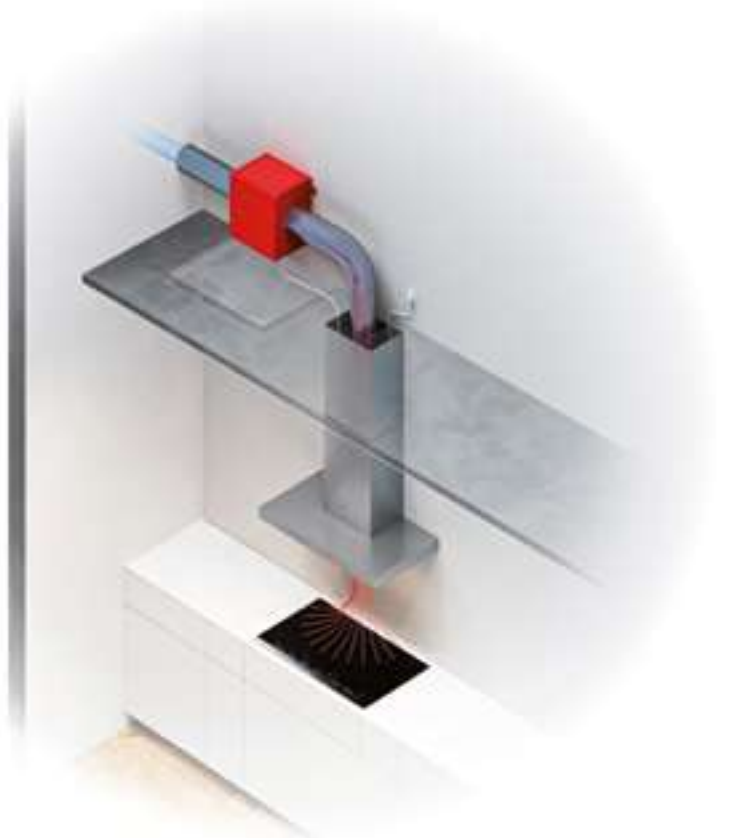

Todos con las mejores prestaciones, mínimo consumo eléctrico y bajo nivel sonoro.
All with best-in-class performance, minimum energy consumption and very low noise level.

C

MOTOR TEJADO ROOF MOUNTED OUTDOOR MOTOR

V.2350 ECO y/and V.3300 ECO



Motores para su colocación en tejado. Totalmente preparados para cualquier inclemencia del tiempo. Gran capacidad de extracción sin ruido.

INCLUIDO

Las unidades con motorizaciones V.2350 y V.3300 Tejado, incorporan de serie 5 m de tubo de extracción de humos SEC System® de Ø203 mm interior y Ø253 mm exterior.

Motors for mounting on the roof top of the house. Suitable for all weathers. High extraction capacity with no noise.

INCLUIDO

The models with the V.2350 and V.3300 Roof motor system, comes with 5 m of S.E.C. fume extractor flue as standard System®, interior Ø 203 mm and exterior Ø 253.

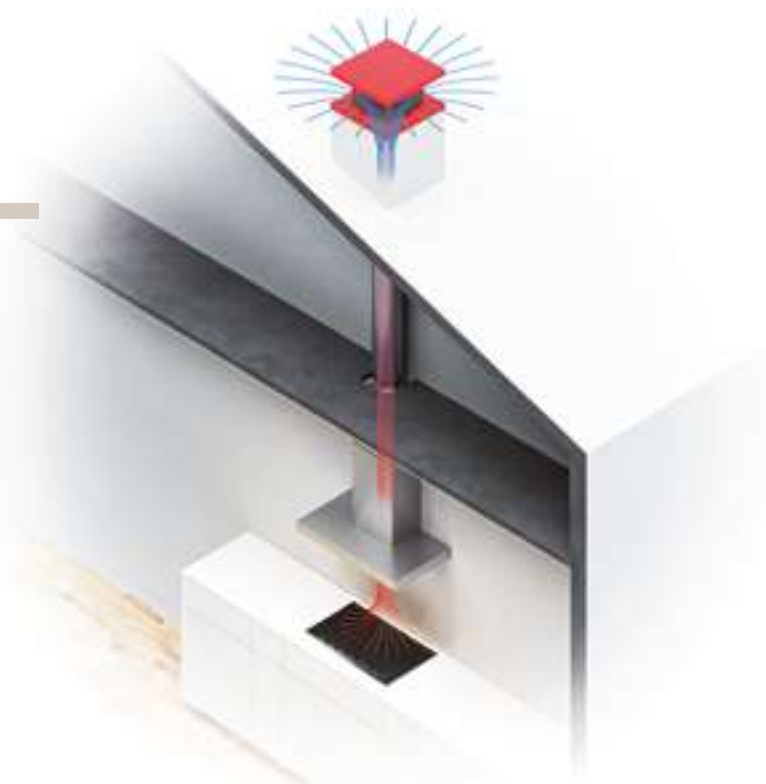

D

MOTOR EXTERIOR DE MURO WALL MOUNTED OUTDOOR MOTOR

V.1300 ECO



Motores para su colocación adosados al muro exterior de la casa. Totalmente preparados para cualquier inclemencia del tiempo. Gran capacidad de extracción sin ruido,

Motors for mounting on the outside wall of the house.

Suitable for all weathers.

High extraction capacity with no noise.

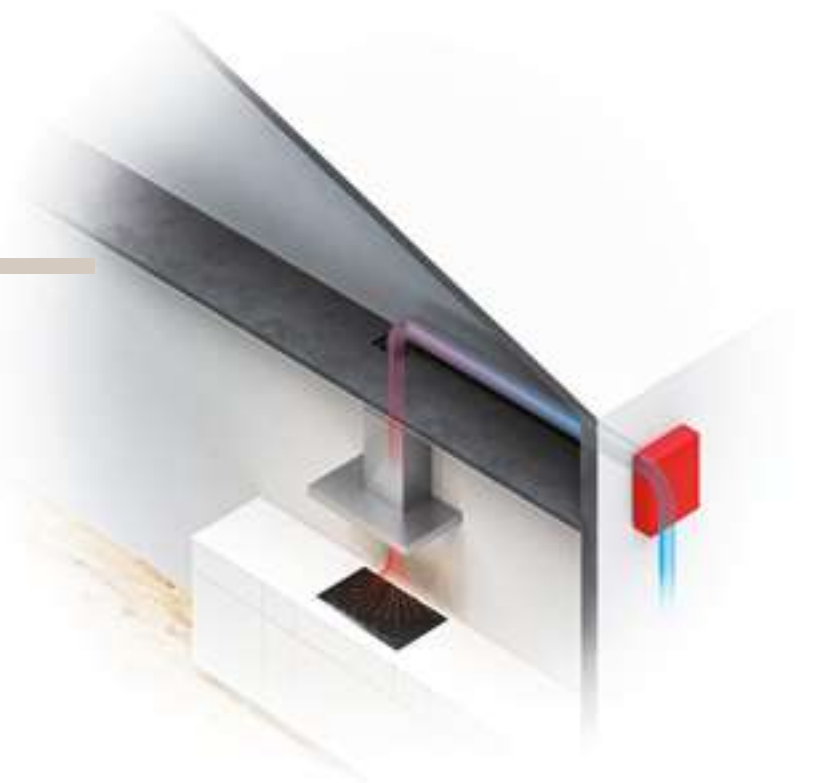

MOTORES INTERMEDIOS EXTERIORES PARA FALSO TECHO EXTERNAL DUCT-IN-LINE MOTORS INSIDE THE FALSE CEILING

B

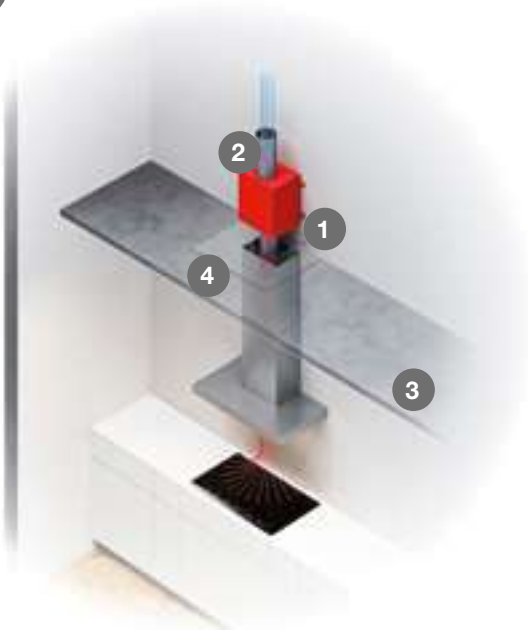

1 Motor
Motor

2 Salida de humos
Duct run

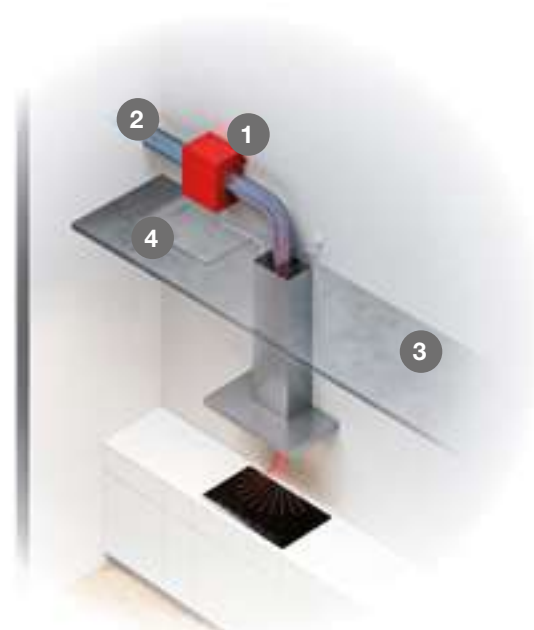

3 Falso techo
False ceiling

4 Registro acceso al motor
Motor access panel

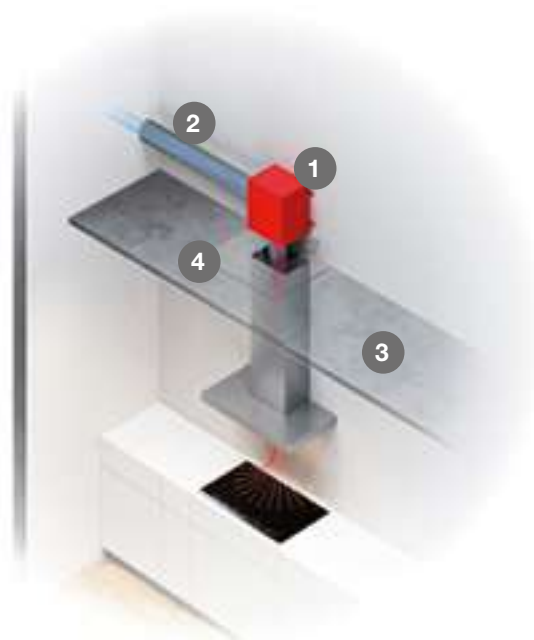

NOTA: Se debe dejar un tubo pasa cables de diámetro 4 cm ya que no se puede cortar el conector del cable.

NOTE: It's necessary to keep a the lead-through of 4 cm diameter, because the connector of the cable cannot be cut.

ESQUEMAS MOTORES INTERMEDIOS EXTERIORES EXTERNAL DUCT-IN-LINE MOTORS DIAGRAMS

B

MOTORIZACIONES ECO ECO MOTORS

Algunos de nuestros modelos incorporan de serie motor ECO. Si el modelo seleccionado por Usted no dispone de serie de esta opción, no dude en consultarnos y le informaremos si es posible instalar un motor ECO en su campana.
Some of our models come standard with ECO motor. If the motor you selected does not have this option as standard, please do not hesitate to contact us. We will inform you if it is possible to install an ECO motor in your hood.

V.1200 ECO

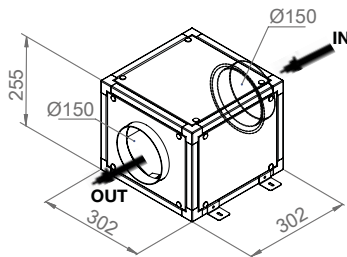

V.2000 ECO

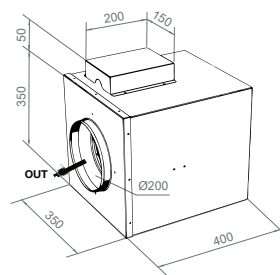

V.1550 N ECO Tipo/ Type 1

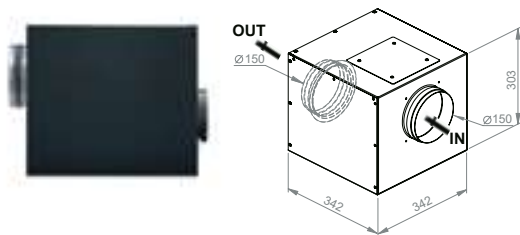

V.1550 N ECO Tipo/ Type 2

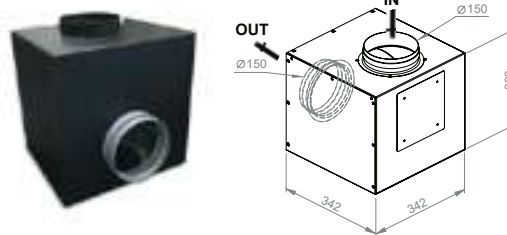

Medidas máximas con soportes
Maximum dimensions with fixings

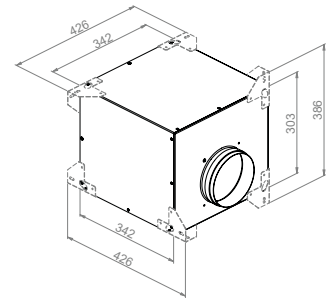

V.2450 ECO Tipo / Type 2

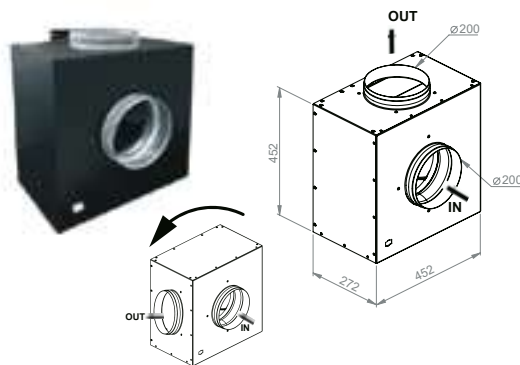

V.3000 N ECO Tipo / Type 2

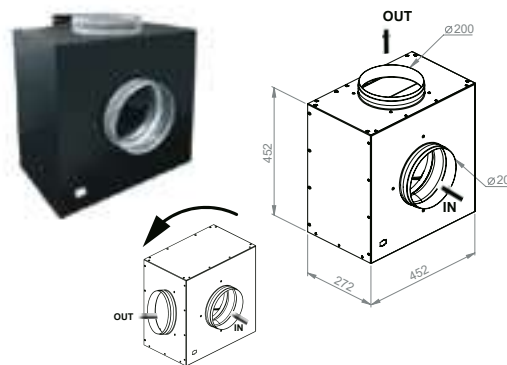

Medidas máximas con soportes
Maximum dimensions with fixings

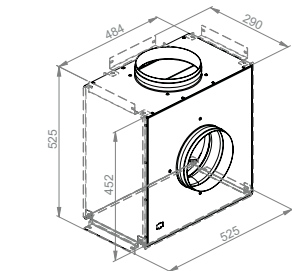

V.2600 ECO Tipo / Type 1

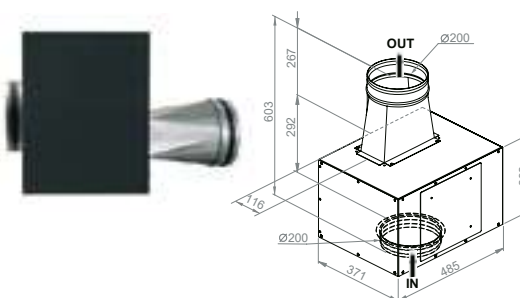

V.2600 ECO Tipo / Type 2

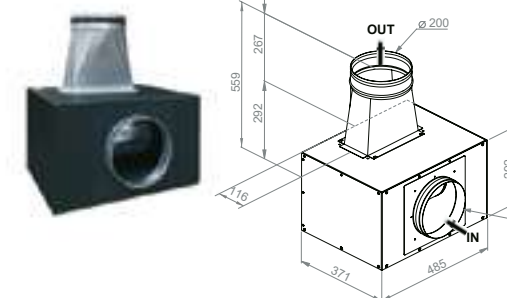

Medidas máximas con soportes
Maximum dimensions with fixings

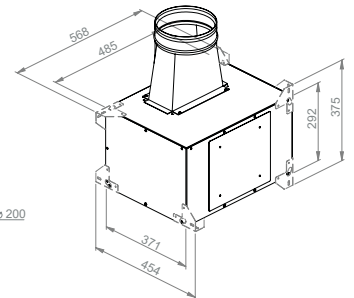

MOTOR EXTERIOR DE TEJADO ROOF MOUNTED OUTDOOR MOTOR (ROOF OR CHIMNEY)

C

Su excelente facilidad de colocación y montaje, su menor envergadura (que mejora mucho su presentación estética), sumada a su alta capacidad de trabajo, hacen que sean las mejores elecciones de motorización para aquellos proyectos en los que puedan proponerse como alternativa a los motores tradicionales.

The easy mounting and installation process with its more compact dimensions (improving the aesthetics) together with its high performance, make the roof outdoor motors an excellent option for those projects where an alternative to traditional indoor motors is possible.

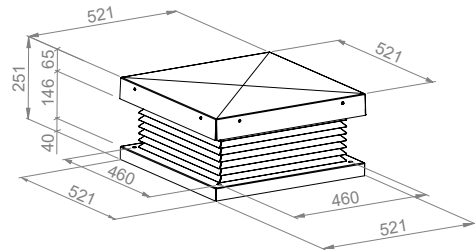
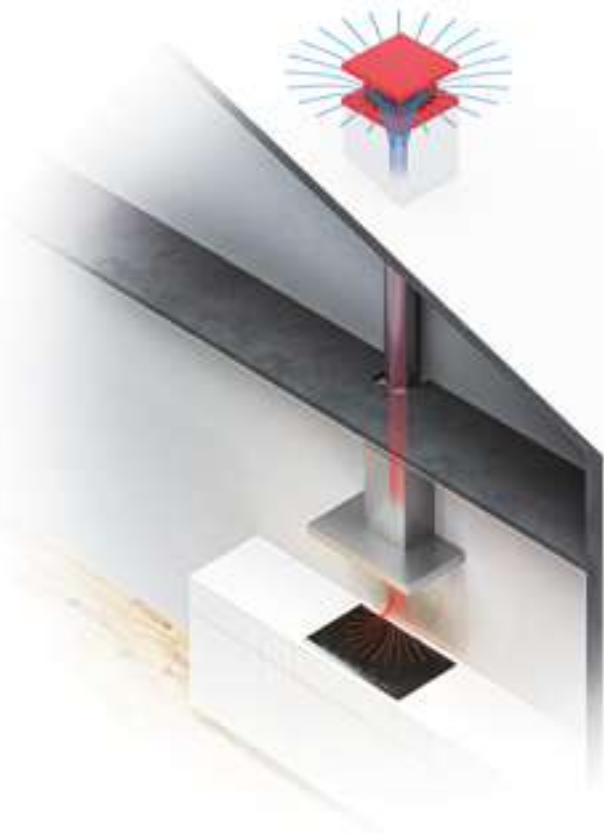

Motor exterior de tejado V.2350 ECO
ROOF Remote Motor V.2350 ECO



**Motor exterior de tejado V.2350 ECO
y V.3300 ECO ESPECIAL**
ROOF Remote Motor v.2350 ECO
and V.3300 ECO SPECIAL



**Montaje sobre la caja de soporte
insonorizada.**
Installation over Sound proof
Support Box.

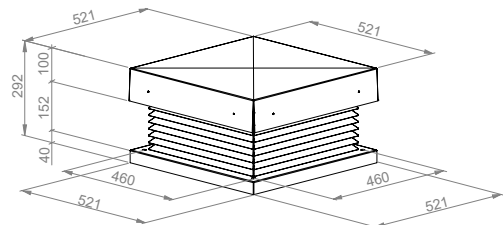

Motor exterior de tejado V.3300 ECO
ROOF Remote Motor V.3300 ECO

NOTA: Se debe dejar un tubo pasa cables de diámetro 4 cm ya que no se puede cortar el conector del cable.

MUY IMPORTANTE: la ubicación y acceso al motor, debe de ser "seguro" para los Sres. del Servicio de Asistencia Técnica, a fin de que puedan realizar trabajos de mantenimiento o posibles reparaciones. Si la ubicación del motor presenta riesgos para las personas, Pando se reserva el derecho de no actuación, hasta que las condiciones sean las adecuadas para la seguridad del S.A.T.

Note: It's necessary to keep a lead-through of 4 cm diameter, because the connector of the cable cannot be cut.

VERY IMPORTANT: The position of and the access to the motor must be safe to operate of After-Sales technical and maintenance workers. Should the motor position provide any risk to personnel, Pando reserves the right to refuse servicing the product until such safe conditions exist again.

MOTOR EXTERIOR DE MURO WALL MOUNTED OUTDOOR MOTOR

D

Motor de instalación a muro que facilita la instalación del motor en el exterior en casi cualquier tipo de vivienda. Fácil de instalar con distintas posibilidades de montaje, esto hace que este tipo de instalación sea muy buena alternativa.

The wall-mounted motor facilitates the installation of the motor outdoors in almost any type of home. The easy installation and the various mounting possibilities makes this type of installation an excellent alternative.

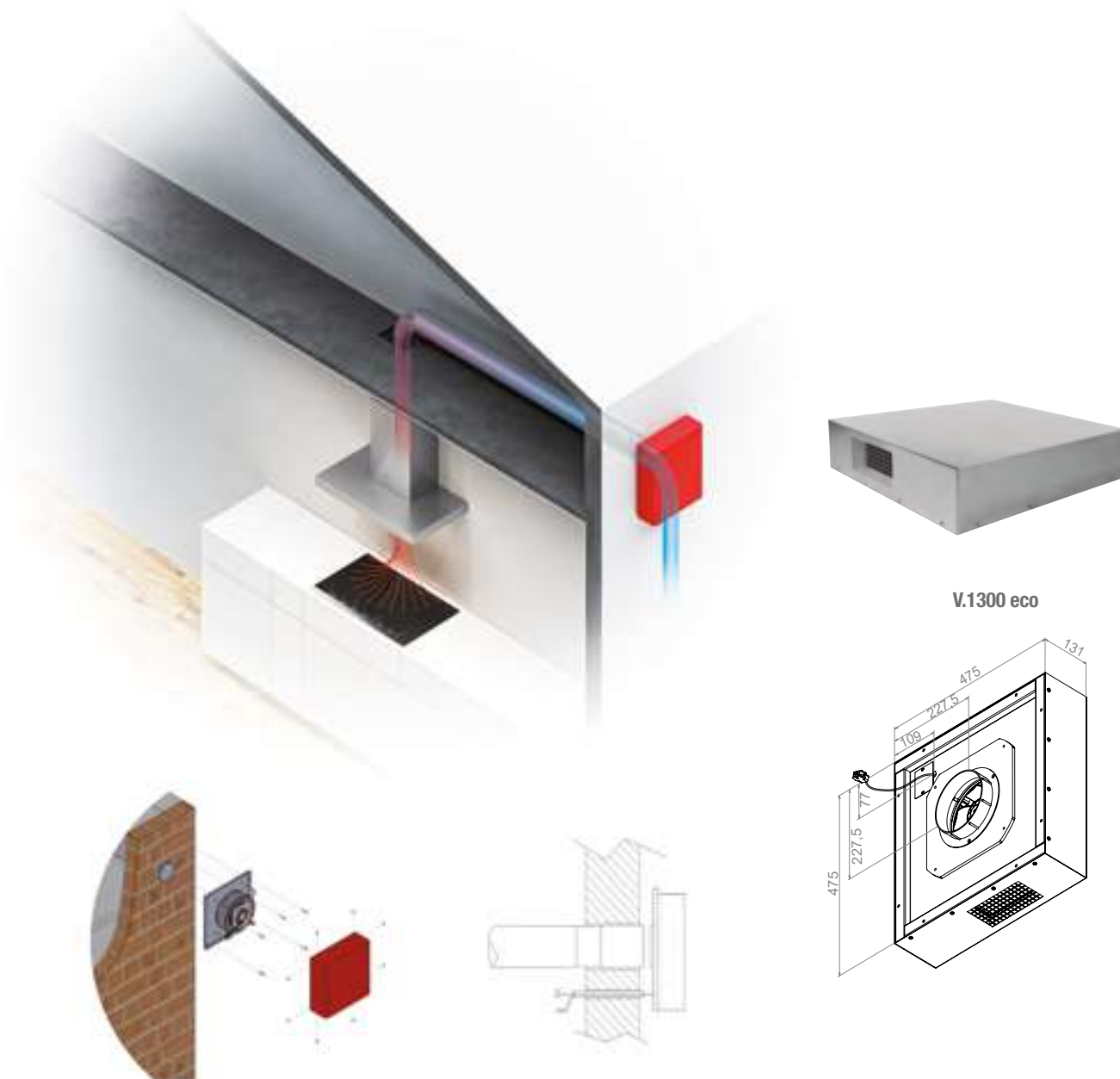

NOTA: Se debe dejar un tubo pasa cables de diámetro 4 cm ya que no se puede cortar el conector del cable.

MUY IMPORTANTE: La ubicación y acceso al motor, debe de ser "seguro" para los Sres. del Servicio de Asistencia Técnica, a fin de que puedan realizar trabajos de mantenimiento o posibles reparaciones. Si la ubicación del motor presenta riesgos para las personas, Pando se reserva el derecho de no actuación, hasta que las condiciones sean las adecuadas para la seguridad del S.A.T.

Note: It's necessary to keep a lead-through of 4 cm diameter, because the connector of the cable cannot be cut.

VERY IMPORTANT: The position of and the access to the motor must be safe to operate of After-Sales technical and maintenance workers. Should the motor position provide any risk to personnel, Pando reserves the right to refuse servicing the product until such safe conditions exist again.

SISTEMAS DE FIJACIÓN DE FILTROS DE CARBÓN ACTIVADO RECIRCULATION KIT INSTALLATION IN DUCTLESS SYSTEM



QR SISTEMAS FIJACIÓN
QR KIT INSTALLATION

La recirculación o reciclaje del aire extraído por una campana extractora de humos, se realiza a través de unos filtros especiales de carbón activado. Su función es la de purificar el humo extraído y enviarlo nuevamente al recinto. Esta modalidad, sólo debe utilizarse en los casos en que no sea posible efectuar una instalación de tubo conductor de humos que lleve los gases al exterior de la cocina, o bien, cuando al lugar donde van a parar estos, pueda molestar el olor o el humo extraído. Esta última utilidad también se propone con fines ecológicos, para evitar lanzar a la atmósfera gases contaminantes.

Ductless option is designed to be used only in situations where running a duct isn't possible. In a ductless scenario, you will have to use a carbon filter. This filter will clean the air from odors, releasing the purified and clean air back into your kitchen through the vent holes located at the top of the extension flue.

The recirculation system should only be used when an evacuation of the odors to the exterior is imposible. The use of charcoal filters avoids the pollution with polluting gases from cooking.

OPCIÓN A / OPTION A

FILTROS FCA REDONDOS:

Se colocan en horizontal o vertical, enroscados en los laterales del motor, mediante un cuarto de vuelta en el sentido de las agujas del reloj.

ROUND FCA FILTERS.

These are fitted horizontally or vertically, screwed to the sides of the motor by a quarter turn clockwise.



Volutas de motor en posición horizontal
Motor volutes in horizontal position



Volutas de motor en posición vertical
Motor volutes in vertical position

OPCIÓN B / OPTION B

FILTROS FCA/FCLR AE PLANOS:

Se sitúa en la pestaña interior, donde van colocados los filtros metálicos, detrás de estos o previa colocación de la bandeja de soporte de filtros FCA/FCLR AE, encajados en esta.

FLAT FCA / FCLR AE FILTERS.

Fitted on inside tab, where the metal filters are mounted, behind them or before fitting the FCA/ FCLR AE filter support tray.

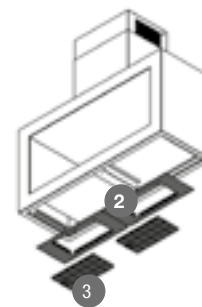
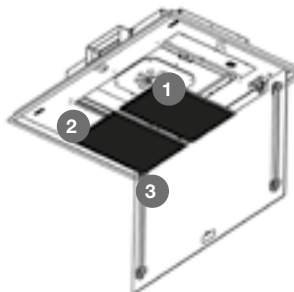

OPCIÓN C / OPTION C

FILTROS INOXIDABLES CON CARTUCHO:

Se colocan los FCLR AE encajados en la cara posterior e interior del filtro metálico, llevan pestañas y anclajes de cierre.

STAINLESS STEEL FILTERS WITH CARTRIDGE.

The FCLR AE are fitted at the back or inside the metal filter. They have tabs and fixing points.



VISTO POR A

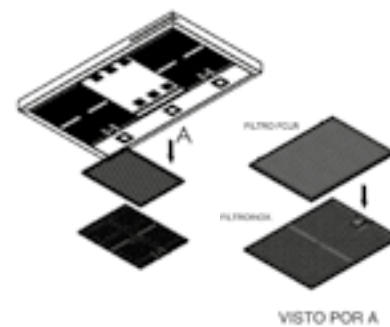

VISTO POR A

OPCIÓN D / OPTION D

DIFUSOR:

Se colocan las cápsulas cerámicas FCCR AE que van sujetas en una jaula de acero, dentro del cuerpo del difusor.

DIFFUSER.

FCCR AE ceramic capsules are fitted, secured in a steel cage inside the body of the diffuser.

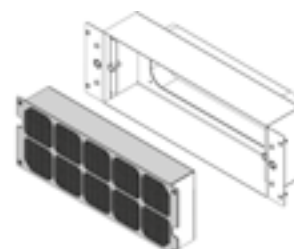
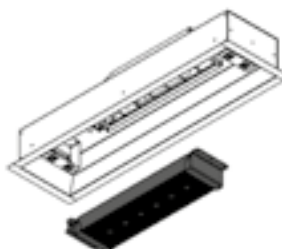

BASE INOX PARA GRUPO FILTRANTES STAINLESS STEEL BASE FOR FILTERING SETS



Este producto solo se suministra bajo pedido conjunto con el grupo filtrante correspondiente. Esta base inox se fabrica para cualquiera de nuestros grupos filtrantes a medida, bajo presupuesto.

Cualquier variación sobre las medidas indicadas, bajo presupuesto.

This stainless steel base is only supplied on request together with the corresponding filter group. This stainless steel base is manufactured for any of our filtering sets custom-made, on request

Any variation to the above sizes, on request.

Base INOX EVO Stainless Steel base for EVO

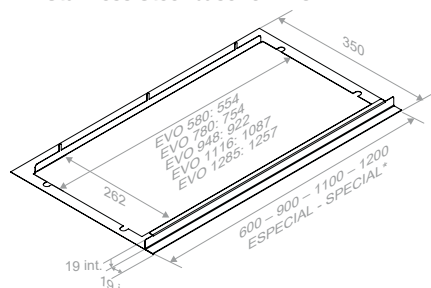

Base	Ref.
Base INOX EVO 580	009136
Base INOX EVO 780	009137
Base INOX EVO 948	009985
Base INOX EVO 1116	009986
Base INOX EVO 1285	009989

Base INOX NEO/NCR Stainless Steel base for NEO/NCR

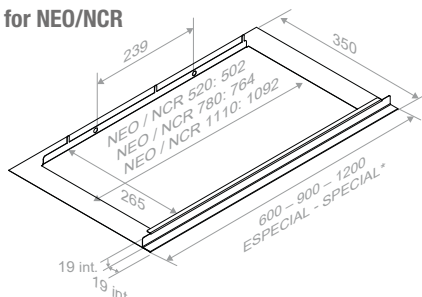

Base	Ref.
Base INOX NEO / NCR 520	009138
Base INOX NEO / NCR 780	009139
Base INOX NCR 1110	010080

Base GTI Base for GTI

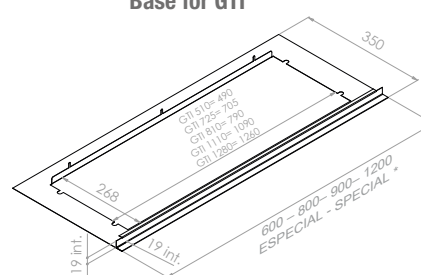

Base	Ref.
INOX/S.S. GTI 510	010203
INOX/S.S. GTI 725	010204
INOX/S.S. GTI 810	010205
INOX/S.S. GTI 1110	010206
INOX/S.S. GTI 1280	010207

Base INOX GRV Stainless Steel base for GRV

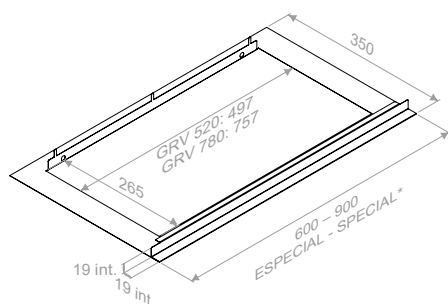

Base	Ref.
Base INOX GRV 520	010118
Base INOX GRV 780	010119

Base INOX PRO Stainless Steel base for PRO

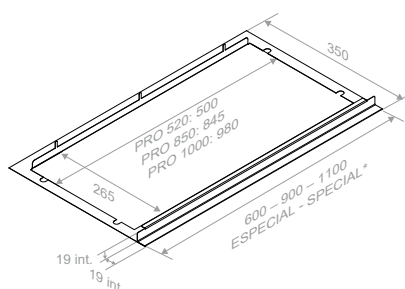

Base	Ref.
Base INOX PRO 520	009823
Base INOX PRO 850	009824
Base INOX PRO 1000	009987

Notas / Notes

*MEDIDA ESPECIAL bajo presupuesto
*SPECIAL SIZE under request

DIFUSOR DE TECHO CEILING DIFFUSER



Para la instalación, crear en el falso techo un espacio de 665 mm x 165 mm con una altura mínima de 210 mm.

(1) Distancia mínima entre campana y difusor de 2 m.
(1)

For installation cut out an area of 665 mm x 165 mm at a minimum height of 210 mm in the false ceiling.

(1) Minimum distance between hood and diffuser of 2 m.

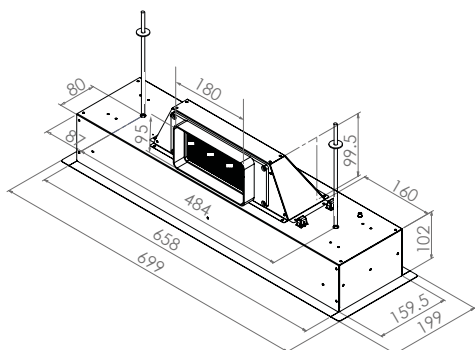
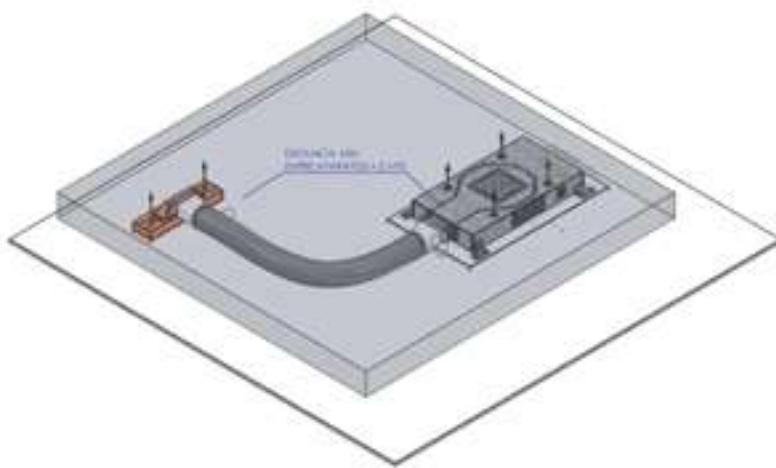

Descripción / Description	Medidas Encastre Built in Sizes	Ref.
Difusor de techo INOX SIN filtro cerámico Ceiling diffuser Stainless Steel WITHOUT ceramic carbon filter	165 x 665 mm	009919
Difusor de techo INOX CON filtro cerámico Ceiling diffuser Stainless Steel WITH ceramic carbon filter	165 x 665 mm	009920
Difusor de techo BLANCO SIN filtro cerámico Ceiling diffuser WHITE WITHOUT ceramic carbon filter	165 x 665 mm	009959
Difusor de techo BLANCO CON filtro cerámico Ceiling diffuser WHITE WITH ceramic carbon filter	165 x 665 mm	009960

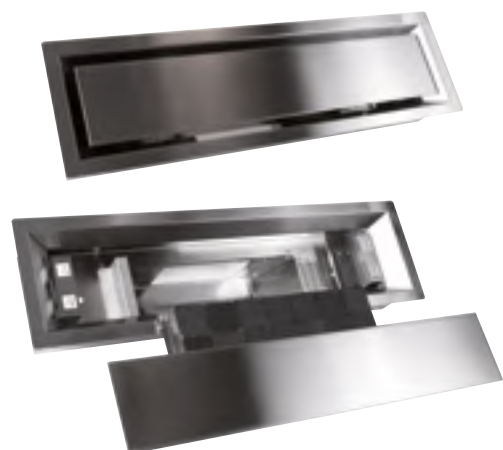

FILTRO CERAMICO REACTIVABLE DE ALTA EFICIENCIA + DIFUSOR

Gracias a las excelentes prestaciones de estos filtros CERAMICOS DE ALTA EFICIENCIA de última generación (FCCR), son posibles diferentes opciones de instalación de manera que cualquier modelo de campana puede equiparse con ellos; esto se consigue usando un DIFUSOR DE TECHO o un DIFUSOR DE ZÓCALO. Estos accesorios le permiten obtener una calidad Premium en la circulación del aire.

HIGH-EFFICIENCY reactivatable CERAMIC active carbon filter + DIFFUSER

Thanks to the excellent performance of these new latest-generation HIGH-EFFICIENCY CERAMIC filters (FCCR), different fitting options are available so that all hood models can be equipped with them.

This is done using a CEILING DIFFUSER or a SPECIAL PLINTH DIFFUSER.

These fittings enable you to benefit from a totally premium recirculation quality.

REDUCCIÓN DEL DIÁMETRO DE TUBO CONDUCTOR DE HUMOS DUCTING ELBOWS, ADAPTORS AND REDUCERS

Conviene tener en cuenta las siguientes indicaciones cuando por causas del recorrido del tubo conductor de humos, debe de realizarse una reducción del conducto. En primer lugar debe quedar bien claro que realizar reducciones de diámetro de tubo, SIEMPRE IMPLICA TENER PERDIDAS DE ASPIRACIÓN. Por tanto, cuando debemos realizarlas "FORZOSAMENTE", debemos tener en cuenta las siguientes premisas:

It is important to note the following methods of how ductwork reduction is achieved. A reduction in ductwork diameter ALWAYS results in a loss of airflow.

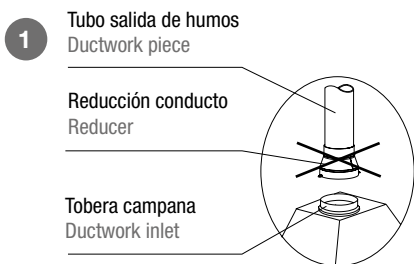

No efectuar nunca una reducción de diámetro de tubo inmediatamente a la salida de la tobera de la campana
Do not install a ductwork reduction immediately after the motor outlet.

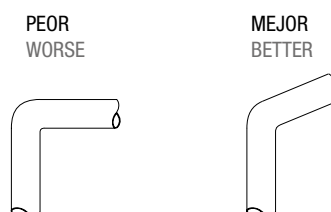
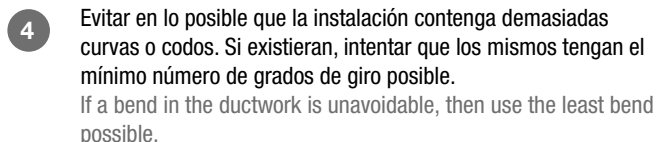
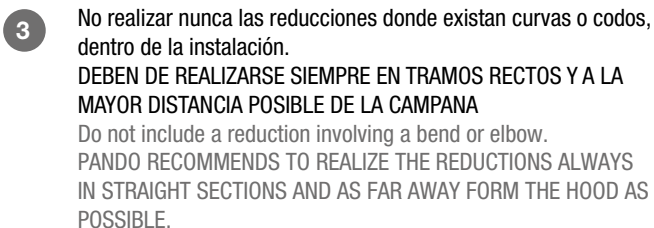
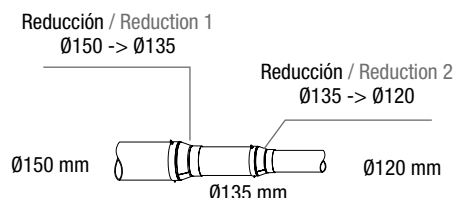
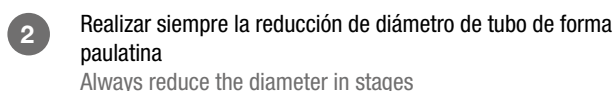

Consecuencias que puede presentar las instalaciones con reducciones del diámetro de tubo:

- Reducción de la aspiración
- Aumento de la condensación
- Aumento del sonido del motor
- Incremento de acumulación de líquidos en el interior del tubo de salida de humos

Consequences from reduced ductwork sizes.

- Reduction of power of aspiration.
- Increased condensation.
- Increased noise.
- Forming of liquids inside the ducting parts.

ACCESORIOS
ACCESSORIES

TUBOS EXTRACCIÓN DE HUMOS SMOKE EXTRACTION DUCTINGS

■ Unidad mínima de venta 5 m.

CARACTERÍSTICAS: Tubo flexible fabricado por múltiples capas de aluminio y poliéster que envuelven y recubren un centro de acero en forma de espiral muy resistente. Este tubo no genera ningún tipo de gas tóxico en caso de incendio. Temperatura de trabajo -30° C a + 150° C. Presión de trabajo hasta 3000 Pa.

■ Minimum unit of sale 5 m

FEATURES: Flexible ducting made by multiple layers of aluminium and polyester lining that envelop and coat a steel core in a very resistant spiral shape. This type of flexible ducting does not generate any kind of toxic gas in the event of a fire. Working Temperature -30° C to + 150 °C. Working pressure up to 3000 Pa.

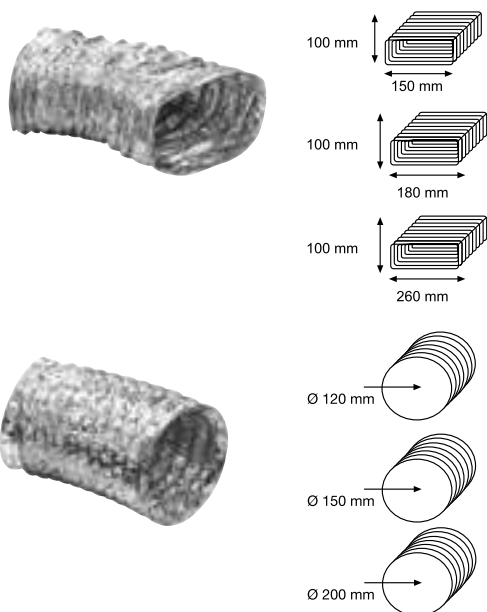

	5 m	10 m
Descripción / Description	Ref.	Ref.
Tubo rectangular equivalente a Ø120 Ø120 rectangular spiral pipe	009802	006743
Tubo rectangular equivalente a Ø150 Ø150 rectangular spiral pipe	009182	006745
Tubo rectangular equivalente a Ø200 Ø200 rectangular spiral pipe	009803	006747
Tubo circular de a Ø120 120 circular spiral pipe	009804	006742
Tubo circular de a Ø150 150 circular spiral pipe	007234	006744
Tubo circular de a Ø200 200 circular spiral pipe	009805	006746

ACCESORIOS
ACCESSORIES

TUBOS EXTRACCIÓN DE HUMOS S.E.C. SYSTEM® SMOKE EXTRACTION DUCTINGS S.E.C. SYSTEM®

CARACTERÍSTICAS: Conductos flexibles aislados de aluminio y poliéster. Constan de un conducto interior perforado con doble cámara, relleno por un compuesto de 25 mm de material aislante y envuelto con aluminio flexible fono-absorbente y micro-poro, todo ello recubierto con malla de fibra.

Los conductos S.E.C. System® ofrecen un buen aislamiento tanto térmico como acústico.

Radio de curvatura mínimo: 0,6 x Ø
Temperatura de trabajo -30° C a + 150° C.

FEATURES: Flexible ducting soundproof made of aluminium and polyester. Consists of a perforated inner duct with dual chamber, filled with a composite with 25 mm of insulating material and wrapped with phono-absorbent and micro-pore flexible aluminium, all of which is covered with mesh fibre.

The S.E.C. System® ducts offer a good level of heat and acoustic isolation.

Minimum bend radius: 0.6 x Ø
Working Temperature -30° C to + 150 °C.

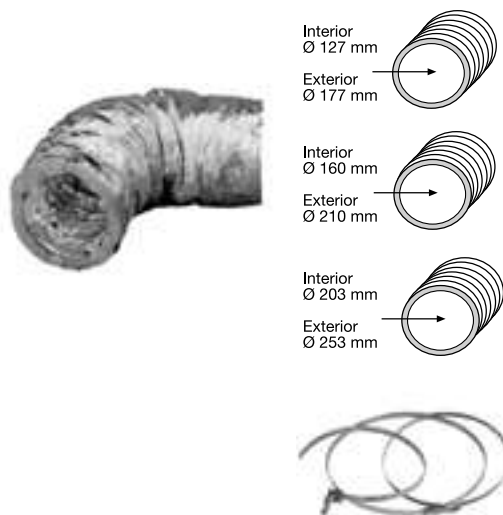

	5 m	10 m
Descripción / Description	Ref.	Ref.
Tubo insonorizado V.1. Ø127 V.1. Ø127 soundproof pipe	009806	007814
Tubo insonorizado V.1. Ø160 V.1. Ø160 soundproof pipe	009807	007815
Tubo insonorizado V.1. Ø203 V.1. Ø203 soundproof pipe	009084	007816

Descripción / Description	Ref.
Brida sujección tubo SEC System Ø125 Ducting fastening flange SEC System Ø125	009314
Brida sujección tubo SEC System Ø150 Ducting fastening flange SEC System Ø150	009315

ACCESORIOS PARA INSTALACIÓN DE CAMPANAS

ACCESSORIES FOR PROPER COOKER HOODS INSTALLATION

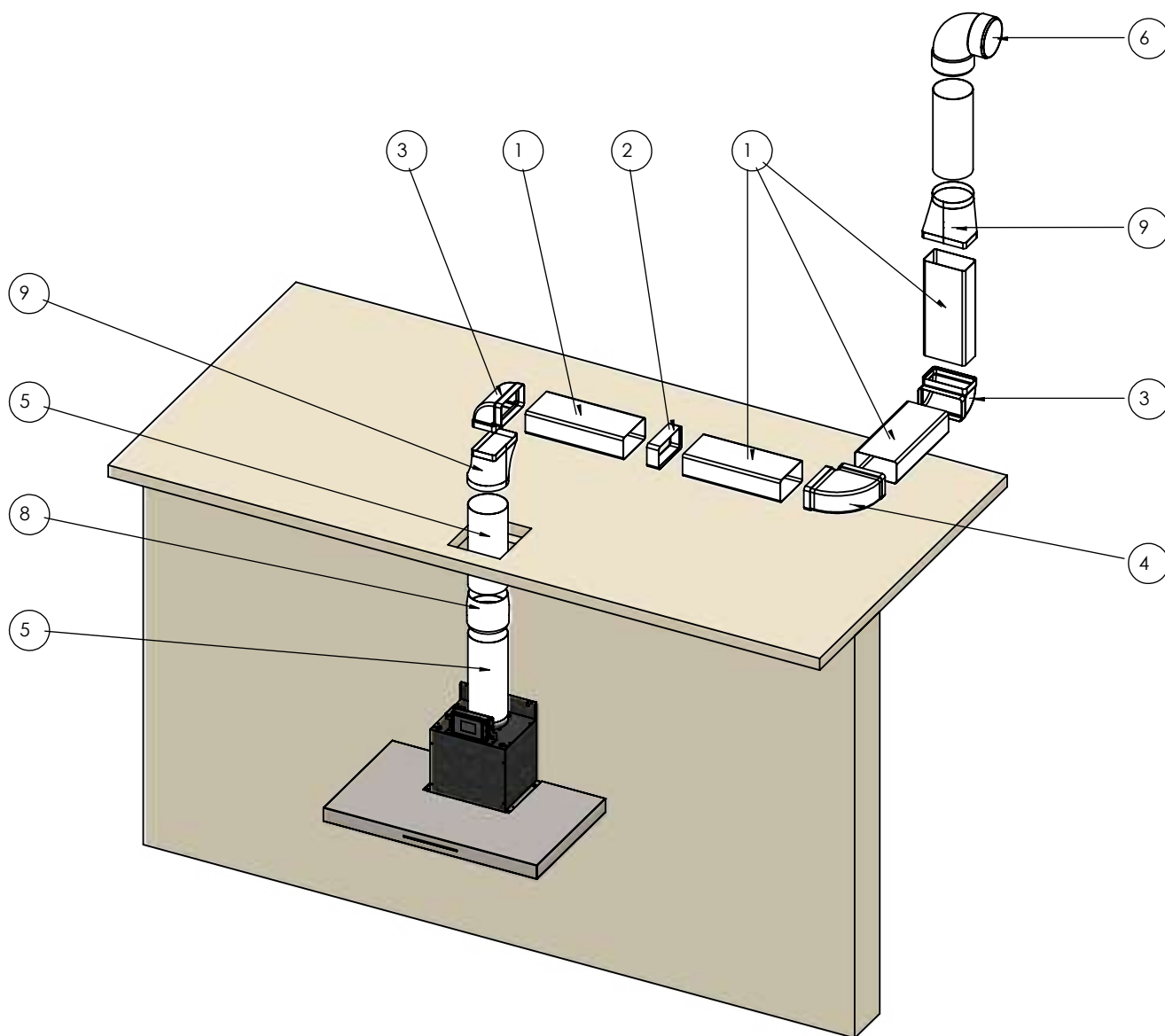

Rectangular / Rectangular 180x90

1

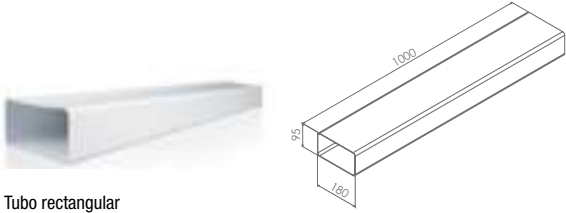

Tubo rectangular
Rectangular duct
180 x 90 mm L= 1000 mm

Ref.

009809

Conducto rectangular
Rectangular duct
180 x 90 mm L= 280 mm

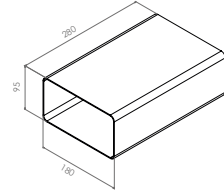

Ref.

640064500088

2

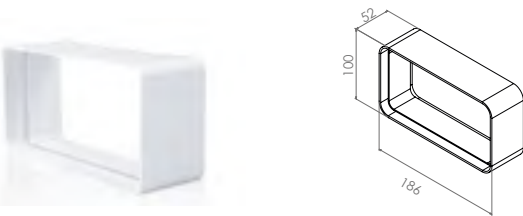

Empalme rectangular
Straight connector
180 x 90 mm

Ref.

010437

3

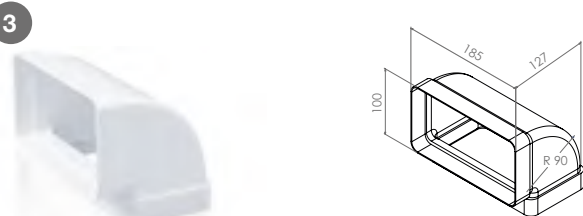

Codo rectangular vertical 90° *
Vertical bend 90°
180 x 90 mm

Ref.

010438

4

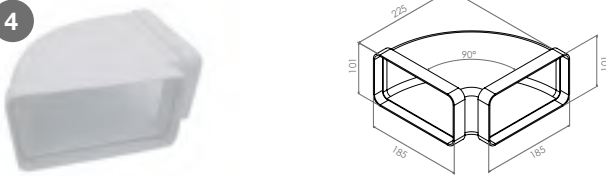

Codo rectangular horizontal 90° *
Straight bend 90°
180 x 90 mm

Ref.

010439

7



Codo vertical redondo
a rectangular. Curva 180x90 mm
Mixed 180x90mm
Ø150 mm

Ref.

010440

9

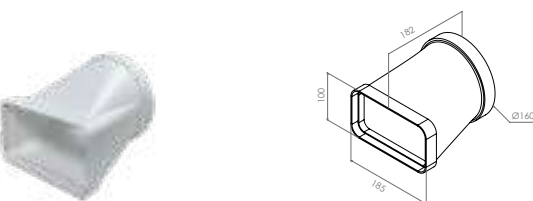

Convertidor Ø150
Connector
90x180

Ref.

009310



Soporte
90x220 (marco)
90x180 (salida)

Ref.

640064500070

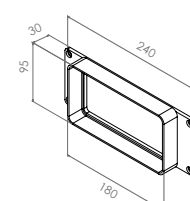

Adaptador
220x55 / 180x90

Ref.

010104

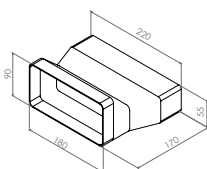

ACCESORIOS PARA INSTALACIÓN DE CAMPANAS

ACCESSORIES FOR PROPER COOKER HOODS INSTALLATION

Rectangular / Rectangular 220x90

1

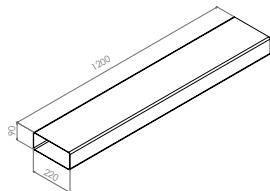

Tubo rectangular
Rectangular duct
220 x 90 mm L= 1200 mm

Ref.
009813

2

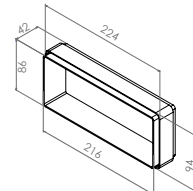

Empalme rectangular
Straight connector
220 x 90 mm

Ref.
009814

3

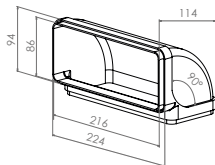

Codo rectangular vertical 90°
Vertical bend 90°
220 x 90 mm

Ref.
009815

4

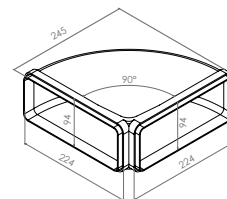

Codo rectangular horizontal 90°
Straight bend 90°
220 x 90 mm

Ref.
010441

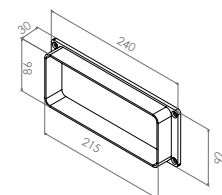

Soporte
90x220
Marco salida

Ref.
640064500081

9

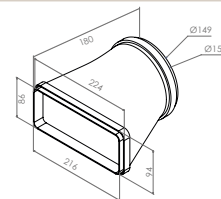

Convertidor recto Ø150 mm / 220 x 90 mm
Mixed straight connector

Ref.
009905

7

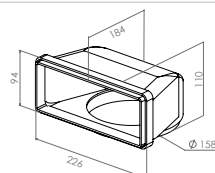

Codo redondo a rectangular
Ø150 90x220 90°
convertidor

Ref.
640064500079

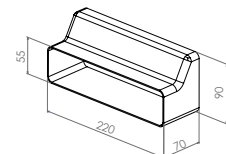

Adaptador
220x55 / 220x90

Ref.
640064500121

Rectangular / Rectangular 220x55

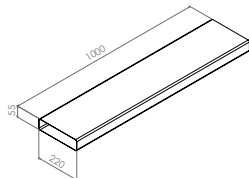

Tubo rectangular
Rectangular duct
220 x 55 mm L: 1000 mm

Ref.
010100

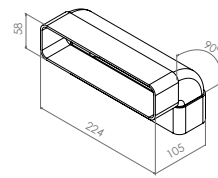

Codo rectangular vertical 90°
Vertical bend 90°
220 x 55 mm

Ref.
640064500111

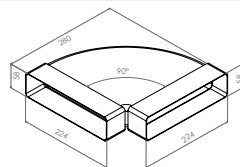

Codo rectangular horizontal 90°
Horizontal bend 90°
220 x 55 mm

Ref.
010101

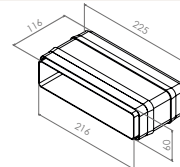

Empalme rectangular
Straight connector
220 x 55 mm

Ref.
010442

Rectangular / Rectangular 220x55 (cont.)



Codo vertical redondo a rectangular
220x55 / Ø125 / 90°

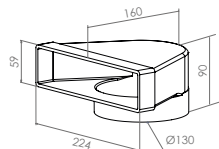

Ref.
640064500116



Empalme
220x55 / Ø125

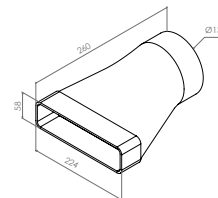

Ref.
010102

Circular / Circular Ø150

5



Tubo redondo
Circular Duct
Ø150 mm L= 1000 mm

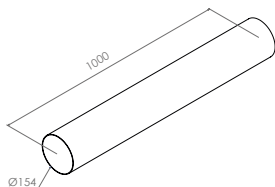

Ref.
009817

8



Empalme redondo
Ø150

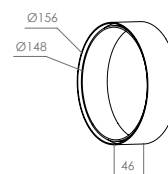

Ref.
009601

6



Codo redondo
Ø150

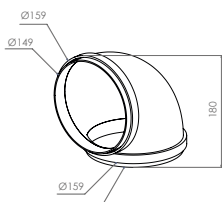

Ref.
009308



Aro reductor
Reducer ring
Ø150 a Ø120 mm

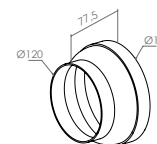

Ref.
640064500012

Rectangular / Rectangular 230x80



Convertidor
80x230
90x220

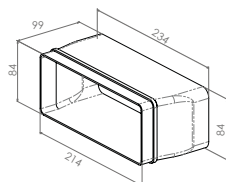

Ref.
640064500080



Ajuste aro
80x230
salida

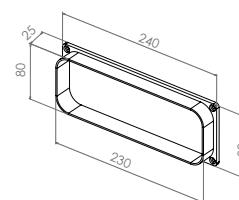

Ref.
640064500033



Convertidor
80x230
Ø150

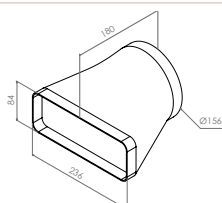

Ref.
640064500053

VÁLVULAS ANTI-RETORNO, VENTANILLAS Y REJILLAS BACKDRAFT SHUTTERS, WINDOWS AND VENTS



Válvulas de cierre anti-retorno Backdraft shutters

Características: Compuerta antiretorno metálica para instalar en la descarga de los ventiladores. Impiden la entrada de olores, corrientes de aire y evitan fugas de calefacción cuando el extractor no funciona.

Features: metal backdraft shutters to install at the exit delivery. Prevents from the entry of odours, air streams and heating leaks from the outside when the extractor is not on.

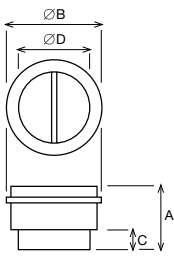

	A	Ø B	C	Ø D	Ref.
Ø 125 mm	107	139	31,5	119,5	006723
Ø 150 mm	121	163,5	35	147	006724
Ø 160 mm	121	173,5	35	157	006725
Ø 200 mm	131,5	214	35	197,5	006726



Ventanillas de apertura por sobrepresión Wall outlet with gravity flat

Características: Persiana de sobrepresión construida en material termoplástico, estabilizado contra los rayos UV. Resistencia a los flujos abrasivos.

Features: Overpressure blind manufactured in thermoplastic material, stabilized against UV rays. Resistance to abrasive flows.

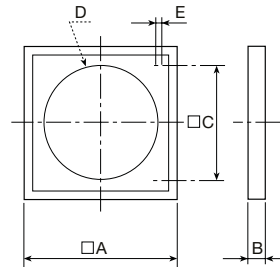

	Ø A	B	C	Ø D	Ø E	Ref.
Ø 130 mm	158	15	110	130	4	006711
Ø 152 mm	178	20	130	152	4	006712
Ø 205 mm	243	21	184	205	5	006713



Rejillas exteriores INOX.
Outdoor grills in S/Steel with backdraft shutter

	Ref.
Ø 150 mm	008769
Ø 200 mm	008770

Características: Realizada en INOX, tiene una doble función: impide la entrada de corrientes de aire, y por otra parte, su rejilla exterior protege de la entrada de cuerpos extraños dentro del conducto.

Features: Made of stainless steel, with a dual function: prevents the entry of air streams, while its outside grill protects from the entry of foreign objects inside the duct.

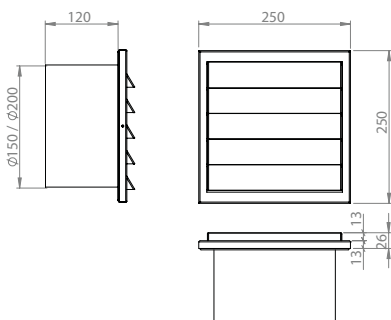

Rejilla final tubo rectangular PVC
PVC ventilation grill for rectangular ducting

	Ref.
180 x 90 mm	009850

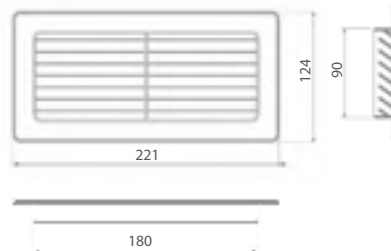

Rejilla final tubo rectangular PVC
PVC ventilation grill for rectangular ducting

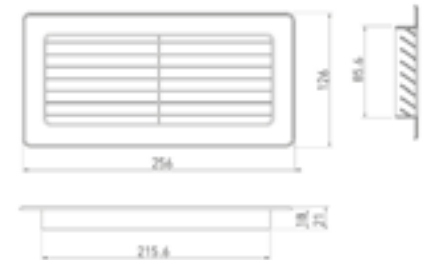

Tubo silenciador para conducto
Silencer tube for pipe



Descripción / Description	mm				Ref.
	Ø A	Ø B	C	D	
Ø 160 mm	160	250	600	700	009952
Ø 200 mm	200	300	600	700	009953

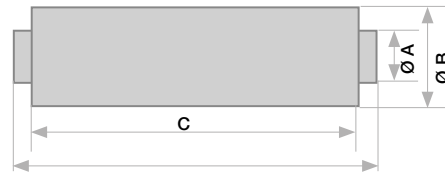

Caja soporte insonorizada para motores de tejado
Soundproof support box for roof motors

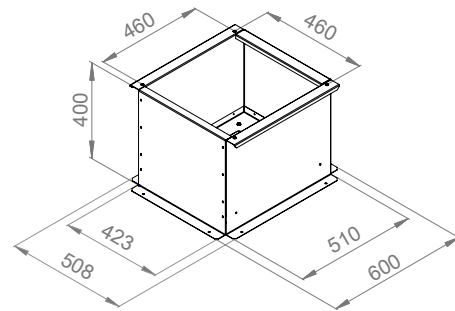

Ref.

008624

Características: Fabricada en acero galvanizado, interior del plenum con sistema de insonorización S.E.C. System by Pando, ideal para reducir la pérdida de caudal y disminuir el nivel sonoro. Aconsejable para instalaciones de conducto que tengan un recorrido de campana a motor inferior a 4 m.

Features: Manufactured in galvanized steel, plenum interior has S.E.C. soundproof system System by Pando, ideal to reduce the loss of flow and to reduce the noise level. Recommended for piping installations with a distance of less than 4 m from hood to motor.

LIMPIEZA Y MANTENIMIENTO MAINTENANCE AND CARE

Campanas DEKTON® / DEKTON® cooker hoods

Debido a su porosidad prácticamente nula, la superficie ultra compacta Dekton® es altamente resistente, tanto a las manchas ocasionadas en el uso cotidiano como a productos químicos, siendo ideal para su uso en la cocina.

Para la limpieza habitual se recomienda el uso de un limpiador de encimeras de piedra especializado, consultar web, junto con una esponja o estropajo de fibras suaves. En caso de no disponer de este producto, la mejor opción es el uso de agua y jabón neutro.

- Evitar radiaciones directas de muy alta temperatura como chimeneas, barbacoas, etc.
- Evitar el contacto directo con llama.
- No pulir la superficie. Evitar utilizar estropajos metálicos o con partículas abrasivas.

Consulte la página web www.dekton.com para más detalles y métodos de limpieza, mantenimiento en general y exposición a sustancias químicas.

Due to its practically zero porosity, the ultra-compact Dekton® surface is highly resistant, both to stains resulting from everyday use and to chemicals, making it ideal for use in the kitchen.

For regular cleaning it is recommended to use a specialised stone worktop cleaner (consult website) with a soft fibre cloth or sponge. If this product is not available, the best option is to use water and neutral soap.

- Avoid direct radiation at very high temperatures such as fireplaces, barbecues, etc.
- Avoid direct contact with flame.
- Do not polish the surface. Avoid using metal scouring pads or those containing abrasive particles.

Consult the www.dekton.com website for further details and methods of cleaning, general maintenance and exposure to chemical substances

Campanas esmaltadas / Enamelled cooker hoods

El esmaltado de las campanas, esta realizado con sistema epoxi y cocción a 200°. Su dureza es excepcional, lo mismo que su durabilidad. No obstante, dependiendo de los productos que utilicemos para su limpieza y mantenimiento, podemos mermar considerablemente sus cualidades.

La mejor opción para realizar una limpieza óptima del EXTERIOR de la campana, es realizarlo a través de una solución jabonosa estandar anti-grasa neutra y aclararlo posteriormente con un paño húmedo. NO UTILIZAR ESTROPAJOS que pueden llegar a rayar el esmalte, realizarlo con paños suaves o esponjas. Evitar empapar la campana con agua en el enjuague, para que ésta no quede estancada en las juntas. Esto podría ocasionar, con el paso del tiempo, principios de oxidación.

Para realizar la limpieza INTERNA de la campana, SE DEBE DESCONECTAR EL APARATO DE LA RED ELECTRICA y no introducir NUNCA paños mojados en exceso. Tener los filtros metálicos perfectamente limpios, evitará de forma efectiva, que la zona interna de la campana se ensucie. El lavado aconsejado es igual al que realicemos en el EXTERIOR del aparato.

En caso de optar por otros productos de limpieza, aconsejamos siempre que estos no sean abrasivos a los esmaltes y QUE ESTEN EXENTOS DE SILICONAS, ÁCIDOS, LEJÍAS, AMONIÁCOS, SOSAS, AGENTES CORROSIVOS Y DERIVADOS.

Enamelling is achieved by epoxy painting and then heating at 200° C. It provides a very hard but brittle surface which has a long life. However care is needed as to cleaning, otherwise damage can occur which will shorten its life dramatically.

For best practice use a soft cloth and soap and water (sparingly) and dry off thoroughly with a further soft cloth. Do not use scouring pads as they will damage the surface allowing water penetration and eventually causing rust spots.

For internal cleaning please SWITCH OFF the hood at the mains switch, unplug, and only use a damp (not wet) cloth. Keeping the metallic grease filters clean will also help the inner parts from getting dirty. Make sure hood is completely dry before replacing plug and switching on.

In the event that other cleaning products are chosen, we always advise that these should not be abrasive on enamel and THEY MUST BE FREE FROM SILICON, ACID, BLEACH, AMMONIAC, SODA, CORROSIVE AGENTS AND DERIVATIVES.

LIMPIEZA Y MANTENIMIENTO MAINTENANCE AND CARE

Campanas inoxidables / Stainless Steel cooker hoods

Para la limpieza y conservación del acero, actuaremos de la misma forma que lo hacemos en las campanas esmaltadas, aplicando en un paño una solución jabonosa neutra y aclarando después con un paño húmedo. Una vez seca la campana, bastará aplicar el Limpiador de Acero Inox. Pando para igualar los distintos brillos o sombras que hayan podido quedar después de la limpieza, dando de esta forma un acabado homogéneo y perfecto.

ES EXPRESAMENTE PERJUDICIAL para el acero Inox, la utilización para su limpieza de ÁCIDOS, SOSAS, AMONÍACOS, CLORUROS o DERIVADOS. Todos ellos pueden destruir las características químicas de los aceros, provocando oxidaciones parciales o totales, puntos negros, sombras de distinto brillo, etc....

Con los ácidos (agua fuerte, sulfamán, lejías, etc), debe de tenerse una especial precaución, puesto que en algunos casos no es necesario que se aplique el producto directamente al acero, basta que el "humo o vapor" que desprende el ácido, puede adherirse a la chapa y provocar los daños descritos anteriormente.

MUY IMPORTANTE:

Debe de tenerse en cuenta en las limpiezas industriales de obra nueva o reforma, que el habitáculo de la cocina debe de quedarse perfectamente ventilado después de su limpieza, para evitar que en el ambiente quede el "humo o vapor" antes descrito. No realizarlo, provocará daños irreversibles en el acero inoxidable. Los responsables de la limpieza igualmente deberán de tener muy en cuenta el "no utilizar productos de limpieza", como los anteriormente expuestos, que perjudican directamente al acero inoxidable.

Stainless Steel surfaces should be cleaned regularly to make sure that your hood will continue to look good. It is a good rule to use a soft damp cloth that has been wetted in warm soapy water using a neutral detergent. Make sure you clean the hood in the direction of the stainless finish. Never use abrasive products. We also recommend using cleaning products specifically for cleaning stainless steel that are available through retail outlets.

Pando realise that getting the perfect result from cleaning stainless steel is not always easy, and so has created a specific Pando cleaning product, a special wipe which is impregnated with a blend of oils that thoroughly cleanses stainless steel and leaves it gleaming longer whilst providing an anti-fingerprint finish.

VERY IMPORTANT:

It is important to remember that when industrial cleaning in new or refurbished rooms that thorough ventilation should be maintained to ensure that there is no irreparable damage to the stainless steel finishes from dust or steam.

Limpiador Inox Pando / Stainless Steel cleaner

Pedido mínimo: 1 Caja de 6 unidades. Portes debidos.

Los portes de este producto serán PAGADOS si se realiza un pedido mínimo de 2 cajas de 6 unidades o si el envío es conjunto con una campana.

Minimum order quantity: 1 box with 6 units. Pay collect on delivery. Transport charges are included if a minimum of 2 box (12 units) are ordered or cleaner is shipped together with a cooker hood.

Filtros de Aluminio e Inoxidable / Metallic grease filters

Los filtros metálicos que equipan las campanas, están realizados en perfil de aluminio y malla del mismo material de aleación ligera. Es importante tener en cuenta que estos filtros deben ser cambiados por otros de repuesto, una vez estén deteriorados, ya que sirven de forma efectiva como corta llamas, ante una esporádica inflamación (evidentemente los filtros deben de estar SIEMPRE perfectamente limpios y sin restos de partículas grasas). Estos filtros pueden ser lavados a mano, con una solución jabonosa anti-grasa estandard, o bien en el lavavajillas. Se recomienda que el lavado a mano se efectúe SIN ESTROPAJO, puesto que puede deteriorar la malla de aleación ligera; lo mejor en este caso es realizar el lavado por inmersión y posterior aclarado.

MUY IMPORTANTE:

Si el lavado se efectúa en el LAVAVAJILLAS, deberán de tenerse en cuenta las instrucciones que cada fabricante tiene, en cuanto se refiere al apartado de lavado de "UTENSILIOS DE ALUMINIO". No obstante, SIEMPRE SERA NECESARIO, que el lavado se efectúe en un programa CORTO, DONDE NO SE UTILICE NI EL SECADO, NI EL ABRILLANTADO.

En caso de efectuar por error un lavado completo con secado y abrillantado, los filtros pueden quedar ennegrecidos o manchados con diferentes tonos.

Metallic filters supplied with Pando hoods are made from aluminium mesh. Once damaged or spoilt they should be replaced as they not only remove grease particles but also act as a fire wall against sudden ignition. They should always be kept clean and grease free. Pando filters can be either washed by hand or in the dishwasher. If by hand the use of a cloth could damage the mesh, so it is best to agitate the mesh in warm soapy water, rinse and air dry.

VERY IMPORTANT:

Should the filter be cleaned in a dishwasher, study the dishwasher instructions carefully as to the care of aluminium utensils. ALWAYS use a short programme with no drying or shining process included, otherwise the filter could end up darkened and or stained.



Ref.

009993

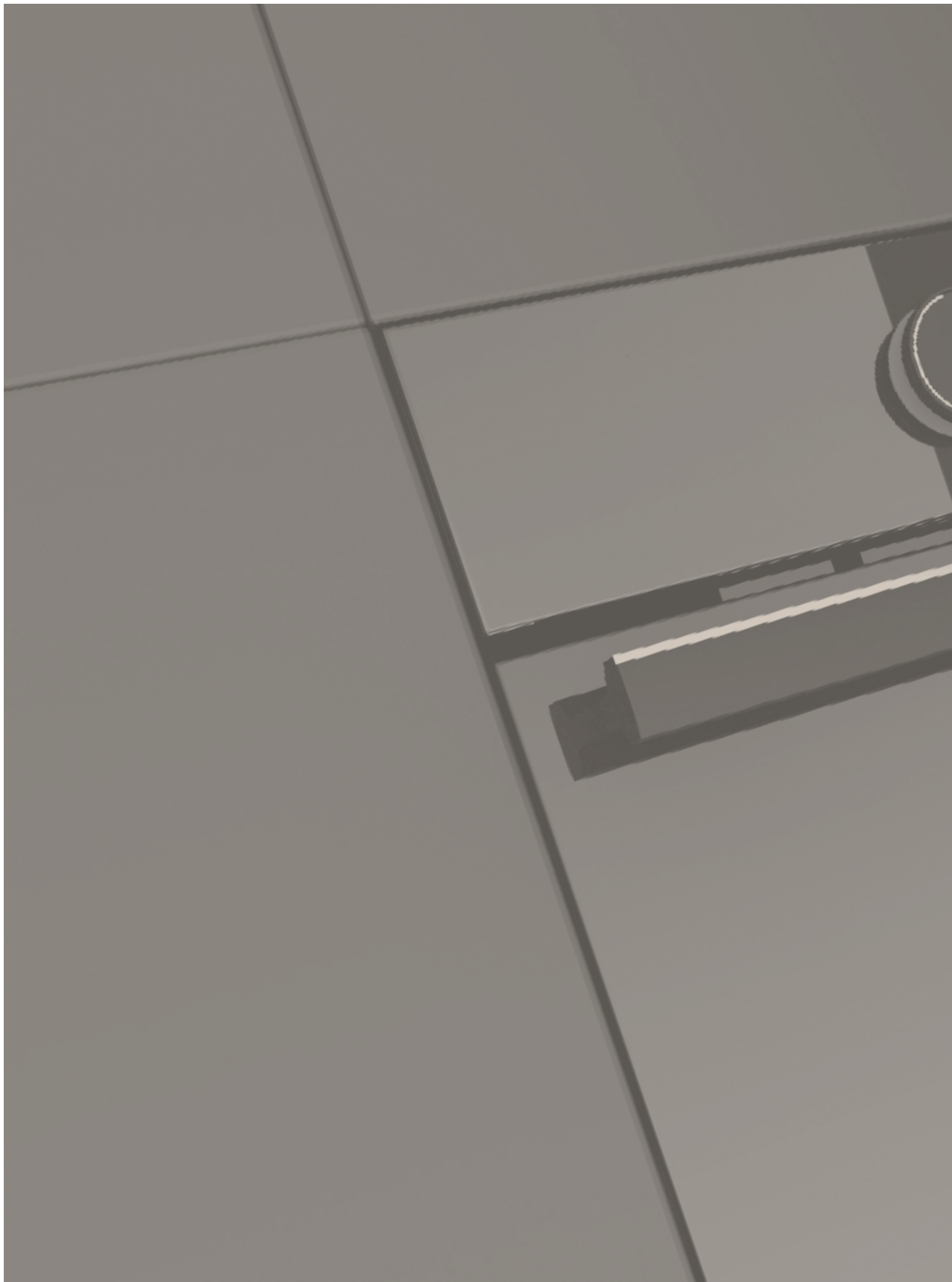



INTEGRAL COOKING

DATOS TÉCNICOS TECHNICAL DATA

Pando



PHB-961



PHP-962



PHT-963



PHT-941



PHTV-942



PHC-943



PHM-950

ES

EN

INSTALACIÓN	INSTALLATION							
Dimensiones producto sin panel frontal (Alto x Ancho x Fondo) (mm)	Product Dimensions without front panel (High x Wide x Deep) (mm)	570 x 545 x 537	570 x 545 x 537	570 x 545 x 537	430 x 545 x 537	430 x 545 x 537	430 x 545 x 537	355-365 x 555 x 312
Dimensiones de Encastre (Alto x Ancho x Fondo) (mm)	Built-in Dimensions (High x Wide x Deep) (mm)	590 x 560-568 x 580	590 x 560-568 x 580	590 x 560-568 x 580	450-460 x 560-568 x 580	450-460 x 560-568 x 580	450-460 x 560-568 x 580	370-380 x 568 x 320-550
Tensión (V)	Voltage (V)	220-240	220-240	220-240	220-240	220-240	220-240	220-230
Frecuencia (Hz)	Frequency (Hz)	50/60	50/60	50/60	50/60	50	50	50
Cable de Alimentación (m)	Connecting Wire (m)	1,1 m without plug	1,1 m without plug	1,5 m without plug	1,1 m without plug	1,1 m without plug	1,1 m without plug	1,5 m without plug
Peso Neto (Kg)	Net Weight (Kg)	35	35	35	30	30	35	22
ACCESORIOS	ACCESSORIES							
Bandeja Plana 30	Flat Tray 30	•	•	•	•	-	-	-
Bandeja Profunda 50	Deep Tray 50	•	•	•	•	•	-	-
Bandeja perforada acero inox (40mm)	Stainless Steel perforated tray (40mm)	-	-	-	-	•	-	-
Bandeja de cristal	Removable Tray System	-	-	-	-	-	•	-
Bandeja extraíble	Glass tray	-	-	-	-	•	-	-
Parrilla Reforzada	Reinforced Grid	•	•	•	•	•	•	•
PRESTACIONES	FEATURES							
Volumen Útil (1) (L)	Net Cavity Volume (1) (L)	70	70	70	•	44	44	22
Rango de Temperaturas	Thermostat Temperature Range	50-250°C	50-250°C	30-270 °C	30-270 °C	30-270 °C	50-250°C	-
CARACTERÍSTICAS	FEATURES							
Potencia Máxima Horno (230 V)	Maximun Oven power (230 V)	3215 W	3552 W	3215 W	3015 W	3400 W	3500 W	2500 W
Función más Eficiente	Best Performing Mode	ECO	ECO	ECO	ECO	ECO	-	-
Índice de Eficiencia Energética (EEI)	Energy Efficiency Index (EEI)	81	81	81	80,8	-	-	-
Clase de Eficiencia Energética	Energy Efficiency Class	A	A+	A+	A+	A+	-	-
Número de Cristales de Puerta	Number Door Glasses	3	4	3	3	3	3	2
Altura de Cocinado	Cooking Levels	5	5	5	3	5	5	2
Reloj/TFT	Clock/TFT Display	Display azul	Display azul	TFT 4"	TFT 4"	TFT 4"	Display azul	Display azul
Luz interior	Inside light	HALOGEN	HALOGEN	HALOGEN	HALOGEN	HALOGEN	HALOGEN	INCANDESCENTE
Bloqueo Teclado	Panel Safety Lock	•	•	•	•	•	•	•
Grill Abatible	Drop Down Grill	•	-	•	•	-	-	•
Soft Close	Soft Close	•	•	•	•	•	-	-
Desconexión automática al abrir la puerta	Automatic disconnection when opening the door	•	•	•	•	•	•	•
Nº FUNCIONES DE COCINADO	NUMBER COOKING FUNCTIONS	10	10	15	15	21	5	9
Bóveda + Solera	Top + Bottom	•	•	•	•	•	-	-
Grill + Solera	Grill + Bottom	-	-	•	•	•	-	-
Grill	Grill	•	•	•	•	•	•	•
Grill Doble	MaxiGrill	•	•	•	•	•	-	-
Grill doble + Turbina	Maxigrill + Fan	•	•	•	•	-	-	-
Bóveda + Solera + ventilador	Top + Bottom + Fan	-	-	•	•	•	-	-
Solera	Bottom	•	•	•	•	•	-	-
Solera + TURBO (Pizza)	Bottom + TURBO (Pizza)	•	•	•	•	•	-	-
TURBO	TURBO	•	•	•	•	•	-	-
Descongelacion	Defrosting	•	•	•	•	•	•	•
ECO	ECO	•	•	•	•	•	-	-
Cocción lenta	Slow cook	-	-	-	-	•	-	-
Mantenimiento temperatura	Keeping warm	-	-	-	-	•	-	-
Vapor	Steam	-	-	-	-	•	-	-
Vapor + TURBO	Steam + TURBO	-	-	-	-	•	-	-
Vapor + Bóveda + Solera	Steam + Top + Bottom	-	-	-	-	•	-	-
Esterilización	Sterilization	-	-	-	-	•	-	-
Regeneración	Regeneration	-	-	-	-	•	-	-
Niveles vapor 35° 80° 100°	Vario steam 35° 80° 100°	-	-	-	-	35-100°	-	-
Calentamiento rápido automático	Automatic quick heating	-	-	-	-	•	-	-
Recetas	Recipes	-	-	•	•	•	-	•
Cocinado a Fuego Lento	Slow Cooking	-	-	•	•	-	-	-
Fermentación	Ferment	-	-	•	•	-	-	-
Microondas	Microwave	-	-	-	-	-	•	•
Microondas + grill	Microwave+Grill	-	-	-	-	-	•	•
Inicio rápido	Quick start	-	-	-	-	-	•	-
Menú de auto-cocina	Auto-cooking menus	-	-	-	-	-	-	14
Memoria cocinado	Cooking memories	-	-	-	-	-	-	3
Pre calentamiento Rápido	Quick Heating	•	•	•	•	-	-	-
Sonda térmica de carne	Meat Probe	-	-	-	-	•	-	-
FUNCIONES DE LIMPIEZA	CAVITY CLEANING FUNCTIONS							
SCS (Steam Clean System by Pando)	SCS Function (Steam Clean System by Pando)	•	•	•	•	-	•	-
Pirólisis	Pyrolysis	-	•	-	-	-	-	-
Vapor	Steam	-	-	-	-	•	-	-

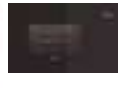

GAMA TOP

PHB-861

PHTV-862

PHP-864

PHB-841

PHM-850

PHM-851

ES

EN

INSTALACIÓN	INSTALLATION						
Dimensiones producto sin panel frontal (Alto x Ancho x Fondo) (mm)	Product Dimensions without front panel (High x Wide x Deep) (mm)	586 x 560 x 550	586 x 560 x 550	586 x 560 x 550	440 x 560 x 550	372 x 540 x 440	362 x 553 x 428
Dimensiones de Encastre (Alto x Ancho x Fondo) (mm)	Built-in Dimensions (High x Wide x Deep) (mm)	590 x 562-568 x 580	590 x 562-568 x 580	590 x 562-568 x 580	450 x 562-568 x 580	380 x 562-568 x 500	380 x 564-568 x 550
Tensión (V)	Voltage (V)	220 - 240	220 - 240	220 - 240	220 - 240	220 - 240	220 - 240
Frecuencia (Hz)	Frequency (Hz)	50-60	50-60	50-60	50-60	50	50
Cable de Alimentación (m)	Connecting Wire (m)	1,1	1,1	1,1	1,1	1	1
Peso Neto (Kg)	Net Weight (Kg)	32	45	42	27	23	19,6
ACCESORIOS	ACCESSORIES						
Bandeja Plana 30	Flat Tray 30	•	•	•	•	-	-
Bandeja Profunda 50	Deep Tray 50	•	•	•	•	-	-
Bandeja perforada acero inox (40mm)	Stainless Steel perforated tray (40mm)	-	-	-	-	-	-
Bandeja de cristal	Removable Tray System	-	-	-	-	-	-
Bandeja extraíble	Glass tray	•	•	•	•	-	-
Bandeja Airfry	Airfry tray	•	-	-	-	-	-
Parrilla Reforzada	Reinforced Grid	•	•	•	•	-	-
PRESTACIONES	FEATURES						
Volumen Útil (1) (L)	Net Cavity Volume (1) (L)	72	72	72	50	34	25
Rango de Temperaturas	Thermostat Temperature Range	30-250°C	30-250°C	30-250°C	30-250°C	90-900W	90-900W
CARACTERÍSTICAS	FEATURES						
Potencia Máxima Horno (230 V)	Maximun Oven power (230 V)	2900	3150	3200	3000	1450	1450
Función más Eficiente	Best Performing Mode	ECO	ECO	ECO	ECO	-	-
Índice de Eficiencia Energética (EEI)	Energy Efficiency Index (EEI)	81,9	74	81,9	85,7	-	-
Clase de Eficiencia Energética	Energy Efficiency Class	A+	A+	A+	A	-	-
Número de Cristales de Puerta	Number Door Glasses	3	3	4	2	-	-
Altura de Cocinado	Cooking Levels	5	5	5	3	-	-
Reloj digital	Digital clock	•	•	•	•	•	•
Luz interior	Inside light	Halógena	LED	Halógena	Halógena	Halógena	Halógena
Bloqueo Teclado	Panel Safety Lock	•	•	•	•	•	•
Grill Abatible	Drop Down Grill	•	•	•	-	-	-
Soft Close	Soft Close	•	•	•	•	•	•
Desconexión automática al abrir la puerta	Automatic disconnection when opening the door	•	•	•	•	•	•
Nº FUNCIONES DE COCINADO	NUMBER COOKING FUNCTIONS	11	25	13	16	10	10
Programas de funcionamiento auto.	Automatic programs	-	13	-	-	8	8
Convencional (Bóveda + Solera) [W]	Conventional (Top + Bottom) [W]	•	•*	•	•	-	-
Convección [W]	Convection [W]	•	•*	•	•	-	-
ECO [W]	ECO [W]	•	•	•	•	-	-
Convencional + ventilador [W]	Conventional + Fan [W]	•	•*	•	•	-	-
Calor radiante superior [W]	Radiant Heat [W]	•	•	•	•	-	-
Doble Grill + ventilador [W]	Double Grill + Fan [W]	•	•	•	•	-	-
Doble Grill [W]	Double Grill [W]	•	•	•	•	-	-
Pizza [W]	Pizza [W]	•	•	•	•	-	-
Solera [W]	Bottom Heat [W]	•	•	•	•	-	-
Solera + Convección	Bottom Heat + Convection [W]	-	-	-	•	-	-
Modo mantener caliente	Keep warm	-	-	-	•	-	-
Modo deshidratación	Drying	-	-	-	•	-	-
Modo cocción lenta	Slow cooking	-	-	-	•	-	-
Descongelar [W]	Defrost [W]	•	•	•	•	-	-
Modo plato caliente	Plate warm	-	-	-	•	-	-
Fermentación [W]	Fermentation [W]	•	•	•	•	-	-
Cocción con sonda	Cooking with probe	-	•	•	-	-	-
Pirólisis [W]	Pyrolysis Self-cleaning [W]	-	-	•	-	-	-
Modo Demo - showroom	Demo mode - showroom	•	-	•	-	-	-
Prog. adición de vapor señalados con *	Prog. steam addition indicated with *	-	3	-	-	-	-
Reloj digital	Digital clock	•	•	•	-	•	•
Temporizador digital	Digital timer	•	•	•	•	•	•
Descongelar	Defrost	-	-	-	-	•	•
Cocinado express	Express Cooking	-	-	-	-	•	•
Funciones predefinidas	Preset function	-	-	-	-	•	•
Diámetro del plato [Ø mm]	Plate diameter [Ø mm]	-	-	-	-	345	315
Señal de fin de cocción	End Cooking signal	•	•	•	-	•	•
Sonda térmica de carne	Meat Probe	-	•	•	-	-	-
FUNCIONES DE LIMPIEZA	CAVITY CLEANING FUNCTIONS						
SCS (Steam Clean System by Pando)	SCS Function (Steam Clean System by Pando)	•	-	-	•	-	-
Pirólisis	Pyrolysis	-	-	•	-	-	-
Vapor	Steam	-	•	-	-	-	-

GAMA PREMIUM



PI 3100



PI 3200



PI 3300



PI 3400

ES	EN				
INSTALACIÓN		INSTALLATION			
Dimensiones producto (mm)	Product Dimensions (mm)	590 x 520	590 x 520	590 x 520	810 x 370
Dimensiones encastre (mms)	Built-in Dimensions (mm)	560 x 490	560 x 490	560 x 490	760 x 340
Tensión (V AC)	Voltage (V AC)	220-240 V	220-240 V	220-240 V	220-240 V
Frecuencia (Hz)	Frequency (Hz)	50-60 Hz	50-60 Hz	50-60 Hz	50-60 Hz
Total W	Total W	6.700 W	7.400 W	7.400 W	6.400 W
Peso Neto (Kg)	Net Weight (Kg)	11	11	11	8
Cristal Vitroceramico templado biselado	Beveled Vitroceramic Glass	•	•	•	•
Cristal - Calidad Keraspectrum	Glass - Quality Keraspectrum	•	•	•	•
Niveles de potencia	Power levels	11	14	14	11
Controles display azul.	Blue display controls.				
Sliders touch control general para inductores	Slider general touch control for induction zones	1	4	4	1
Zonas de cocción	Cooking zones	3	4	4	3
Flexizonas Bridge	BRIDGE Cooking zones	-	2	2	-
QUEMADORES		BURNERS			
Zona A	Zone A	180 mm	-	-	180 mm
Potencia "9" + Power Booster	Power "9" + Power Booster	1100 W / 1400 W	-	-	1100 W / 1400 W
Zona B	Zone B	220 mm	-	-	200 mm
Potencia "9" + Power Booster	Power "9" + Power Booster	2300 W / 3000 W	-	-	1400 W / 2000 W
Zona C	Zone C	280 mm	-	-	300 mm
Potencia "9" + Power Booster	Power "9" + Power Booster	2300 W / 3000 W	-	-	300 mm
Zona Flexi	Zone Flexi	-	4 x 220x180 mm 2100 W	4 x 220x180 mm 2100 W	2300 W / 3000 W
Potencia "9" + Power Booster + Súper Booster	Power "9" + Power Booster + Súper Booster	-	2600 / 3700 W	2600 / 3700 W	-
CARACTERÍSTICAS		FEATURES			
Indicador de tiempo	Time indicator	•	•	•	•
Indicador de potencia	Power indicator	•	•	•	•
Tecla mantener caliente 72°	Keep warm key 72°	•	-	-	•
Indicador de zona activa / modo temporizador	Active zone indicator / timer mode	•	•	•	•
Tecla pausa	Pause key	•	-	-	•
Tecla Stop & Go	Stop & Go / Pause key	-	•	•	-
Elección nivel de cocción	Choice of cooking level	•	•	•	•
Detección automática de recipiente	Automatic detection of recipient	•	•	•	•
Cocción automática	Automatic cooking	•	•	•	•
"3 programas automáticos de cocción 42°C, 72°C,94°C"	"3 automatic cooking programmes 42°C, 72°C,94°C"	-	•	•	-
Indicador conservador de calor	Heat conservation indicator	-	•	•	-
Control de timer / Teclas timmer	Timer control / Timmer keys	-	•	•	-
Tecla bloqueo	Lock key	-	•	•	-
Indicador de puesta en marcha	Startup indicator	-	•	•	-
Deteccion automática de la función bridge	Automatic bridge function detection	-	•	•	-
Airlink	Airlink	-	-	•	-

GAMA PREMIUM



PI 3500



PI 3800



PI DOM



PI TEP

ES	EN				
INSTALACIÓN		INSTALLATION			
Dimensiones producto (mm)	Product Dimensions (mm)	900 x 520	780 x 520	380 x 520	380 x 520
Dimensiones encastre (mms)	Built-in Dimensions (mm)	750 x 490	750 x 490	280 x 485	360 x 490
Tensión (V AC)	Voltage (V AC)	220-240 V	220-240 V	220-240 V	220-240 V
Frecuencia (Hz)	Frequency (Hz)	50-60 Hz	50-60 Hz	50-60 Hz	50-60 Hz
Total W	Total W	11.000 W	11.000W	3.700 W	2.800 W
Peso Neto (Kg)	Net Weight (Kg)	16	16	6	8
Cristal Vitroceramico templado biselado	Beveled Vitroceramic Glass	•	•	•	•
Cristal - Calidad Keraspectrum	Glass - Quality Keraspectrum	•	•	•	•
Niveles de potencia	Power levels	14	14	14	9
Controles display azul.	Blue display controls.				
Sliders touch control general para inductores	Slider general touch control for induction zones	6	6	2	2
Zonas de cocción	Cooking zones	6	6	2	2
Flexizonas Bridge	BRIDGE Cooking zones	3	3	1	1
QUEMADORES		BURNERS			
Zonas de coccion iguales	Equal cooking zones	6 x 220x180 mm 2100 W	6 x 220 x 180 mm 2100 W	2 x 220 x1 80 mm 2100 W	2 x 145 Ø mm
Potencia "9" + Power "Booster" + Súper Booster	Power "9" + Power Booster + Súper Booster	2600 / 3700 W	2600 / 3700 W	2650 / 3700 W	2 x 1400 W - 2800 W
CARACTERÍSTICAS		FEATURES			
Indicador de tiempo	Time indicator	•	•	•	•
Indicador de potencia	Power indicator	•	•	•	•
Tecla mantener caliente 72°	Keep warm key 72°	-	-	-	-
Indicador de zona activa / modo temporizador	Active zone indicator / timer mode	•	•	•	•
Tecla pausa	Pause key	•	-	-	-
Tecla Stop & Go	Stop & Go / Pause key	•	•	•	•
Elección nivel de cocción	Choice of cooking level	•	•	•	•
Detección automática de recipiente	Automatic detection of recipient	•	•	•	-
Cocción automática	Automatic cooking	•	•	•	•
"3 programas automáticos de cocción 42°C, 72°C,94°C"	"3 automatic cooking programmes 42°C, 72°C,94°C"	•	•	•	•
Indicador conservador de calor	Heat conservation indicator	•	•	•	•
Control de timer / Teclas timmer	Timer control / Timmer keys	•	•	•	•
Tecla bloqueo	Lock key	•	•	•	•
Indicador de puesta en marcha	Startup indicator	•	•	•	•
Deteccion automática de la función bridge	Automatic bridge function detection	•	•	•	-
Airlink	Airlink	•	•	-	-



GAMA TOP

ES	EN	PI 3110	PI 3111	PI 3150	PI 3151	PI 3210	PI 3211
	Cristal / Glass	Biselado / Beveled	Recto/Straight	Biselado / Beveled	Recto/Straight	Biselado / Beveled	Recto/Straight
INSTALACIÓN	INSTALLATION						
Dimensiones producto (mm)	Product Dimensions (mm)	590 x 520		590 x 520		590 x 520	
Dimensiones encastre (mms)	Built-in Dimensions (mm)	565 x 495		560x480		560x480	
Tensión (V AC)	Voltage (V AC)	220 - 240		220 - 240		220 - 240	
Frecuencia (Hz)	Frequency (Hz)	50 - 60		50 - 60		50 - 60	
Total W	Total W	7.400		7.400		7.400	
Peso Neto (Kg)	Net Weight (Kg)	10		13		13	
Cristal Vitroceramico templado biselado	Beveled Vitroceramic Glass	PI 3110		PI 3150		PI 3210	
Cristal Vitroceramico templado canto recto	Straight Vitroceramic Glass	PI 3111		PI 3151		PI 3211	
Cristal - Calidad Schoot	Glass - Quality Schoot	•		•		•	
Niveles de potencia	Power levels	10		10		10	
Controles display azul.	Blue display controls.						
Sliders touch control general para inductores	Slider general touch control for induction zones	3		3		4	
Zonas de cocción	Cooking zones	3		3		4	
Flexi zonas Bridge	Flexi BRIDGE Cooking zones	-		•		•	
QUEMADORES	BURNERS						
Zona A	Zone A	180 mm		205 x 185 mm		205 x 185 mm	
Potencia "9" + Power Booster	Power "9" + Power Booster	1500 W / 2100 W		2000 W / 3200 W		2200 W / 3200 W	
Zona B	Zone B	180 mm		205 x 185 mm		205 x 185 mm	
Potencia "9" + Power Booster	Power "9" + Power Booster	1500 W / 2100 W		2000 W / 3200 W		2200 W / 3200 W	
Zona C	Zone C	290 mm		280 mm		205 x 185 mm	
Potencia "9" + Power Booster	Power "9" + Power Booster	3000 W / 3800 W		2800 W / 3700 W		2200 W / 3200 W	
Zona Flexi	Zone Flexi					205 x 185 mm	
Potencia "9" + Power Booster + Súper Booster	Power "9" + Power Booster + Súper Booster	-		-		2200 W / 3200 W	
CARACTERÍSTICAS	FEATURES						
Indicador de tiempo	Time indicator	•		•		•	
Indicador de potencia	Power indicator	•		•		•	
Temporizador 99 min	Timer 99 min	•		•		•	
Tecla pausa	Pause key	•		•		•	
Elección nivel de cocción	Choice of cooking level	•		•		•	
Detección automática de recipiente	Automatic detection of recipient	•		•		•	
Indicador conservador de calor	Heat conservation indicator	•		•		•	
Control de timer / Teclas timmer	Timer control / Timmer keys	•		•		•	
Tecla bloqueo	Lock key	•		•		•	
Indicador de puesta en marcha	Startup indicator	•		•		•	
Indicadores de calor residual	Residual heat indicators	•		•		•	
Cocción constante e ininterrumpida	Constant and uninterrupted cooking	•		•		•	
Temporizador 99 min	99 min timer	•		•		•	
Detección de sartén	Pan detection	•		•		•	
Ventilador de refrigeración con bajo nivel de ruido	Low noise cooling fan	•		•		•	
Apagado automático de seguridad	Automatic safety shut-off	•		•		•	
Panel de control del circuito de la zona bridge	Bridge zone circuit control panel	•		•		•	

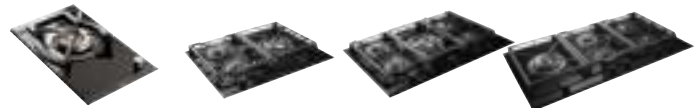

ES	EN	PGA-4130	PGA-4260	PGA-4370	PGA-4491
INSTALACIÓN	INSTALLATION				
Dimensiones producto (mm)	Product Dimensions (mm)	310 x 510	620 x 510	710 x 510	880 x 510
Dimensiones encastre (mm)	Built-in Dimensions (mm)	282 x 482	553 x 473	553 x 473	833 x 483
Tensión (V)	Voltage (V)	220-240 V	220-240 V	220-240 V	220-240 V
Frecuencia (Hz)	Frequency (Hz)	50-60 Hz	50-60 Hz	50-60 Hz	50-60 Hz
Total W	Total W	1,1W	1,1W	1,1W	20W
Cristal Vitroceramico templado biselado	Beveled Vitroceramic Glass	•	•	•	•
Cristal - Calidad Kerablack	Glass - Quality Kerablack	•	•	•	•
Potencia máxima	Maximum power	6.0kW	7.8kW	10.95kW	10.7kW
Instalación gas serie Gas natural (consumo)	Predetermined gas installation Natural Gas (GNC / G20) (consumption)	6.00 kW(G20)	7.80 kW, (G20)	10.95 kW (G20)	10.70 Kw (G20)
Instalación gas opcional Gas butano (consumo)	Optional gas installation Butane gas (GLP / G30) (consumption)	436 gr/h(G30),	567 gr/h(G30)	796 gr/h(G30)	778 gr/h(G30)
Instalación gas opcional Gas propano (consumo)	Optional gas installation Propane gas (GLP-31) (consumption)	429 gr/h(G31)	557 gr/h(G31)	782 gr/h(G31)	764 gr/h(G31)
Control	Control	mando 1 unid	mando 3 unid	mando 5 unid	Touch Control
Zonas de cocción	Cooking zones	1	3	5	5
Parrilla Hierro fundido negro mate	Grill Matte black cast iron	1x	2x	3x	3x
QUEMADORES	BURNERS				
Quemador función dual doble corona	Dual function double crownburner	1 x 6.0kW	1 x .4.0 kW 1 x 2.8 kW 1 x 1.0 kW	1 x .4.0 kW / 1x 2.8 kW 1 x 1.0 kW / 1 x 1.4 kW 1 x 1.75 kW	1 x 3.80 kW / 1 x 2.8 kW 1 x 1.4 kW / 1 x 1.75 kW 1.0 kW
CARACTERÍSTICAS	FEATURES				
Autoencendido integrado en quemador y accionado por el mando.	Integrated autoignition in burner and actuated by control.	•	•	•	•
Dispositivo de seguridad con bloqueo automático	Security dispositive with automatic block	•	•	•	•
Parrilla de hierro fundido con soporte WOK incorporado	Matte black cast iron grill with WOK support added	•	-	-	-
Seguridad por termopar integrada en quemador individual	Security by termopar integrated in each individual burner	-	•	•	-
Mando frontal incorporado	Frontal control incorporated	-	•	•	•
Sistema GAS SEGURO, completamente electrónico	GAS SECURE system, completely electronic	-	-	-	•
Reinicio automático	Automatic restart	-	-	-	•
Indicador y reloj digital	Digital indicator & clock	-	-	-	•
Indicador de calor residual	Residual heat indicator	-	-	-	•
Resistencia agua	Waterproof	IPX0	IPX0	IPX0	IPX0
Touch control frontal	Frontal Touch control	-	-	-	•
Bloqueo de niños, re-encendido y temporizador electrónico.	Parental lock, restart and electrical timer.	-	-	-	•

Lavavajillas integrables

Dishwashers integrated



PLT-7461



PLT-7462 XXL



PLB-7161



PLB-7146

ES

EN

INSTALACIÓN	INSTALLATION				
Dimensiones producto - AlxAnxF (mm)	Product Dimensions - HxWxD (mm)	857 x 598 x 550	815 x 598 x 550	815 x 598 x 550	815 x 448 x 550
Medidas del Embalaje - AlxAnxF (mm)	Built-in Dimensions - HxWxD (mm)	890 x 668 x 670	890 x 645 x 645	890 x 645 x 645	890 x 495 x 490
Tensión (V)	Voltage (V)	220-240	220-240	220-240	220-240
Frecuencia (Hz)	Frequency (Hz)	50	50	50	50
Potencia de conexión (W)	Connected load (W)	1828-2158	1828-2158	1760-2100	1760-2100
Cable de alimentación (m)	Connecting Wire (m)	1,5	1,5	1,5	1,5
Peso Neto (Kg)	Net Weight (Kg)	38	39,5	38	39
Tipo	Type	60 cm Totalmente integrado	60 cm Totalmente integrado	60 cm Totalmente integrado	45 cm Totalmente integrado
Color de la máquina	Color of machine	1(*)	1(*)	1(*)	1(*)
CARACTERÍSTICAS PRINCIPALES	MAIN FEATURES				
Capacidad	Capacity settings	16	16	14	10
Consumo de energía (KWH) / Ciclo	Energy Consumption (KWH) / cycle	0.74	0,559	0.95	0.75
Consumo de agua (L) / Por lavado	Water Consumption (L) / Per cycle	9,0	9,0	9,9	8
Clase energética	Energy Efficiency Class	A	A	D	D
Eficiencia en la limpieza	Cleaning Efficiency	A	A	A	A
Eficiencia de secado	Drying Efficiency	A	A	A	A
Nivel sonoro	Noise Level	42db	43db	45db	45db
Programación diferida	Start delay option	1-24 h	1-24 h	1-24 h	1-24 h
Tercera Bandeja para cubiertos	Third Layer Cutlery Basket	•	•	•	•
Cesta superior ajustable en altura	Height adjustable upper basket	•	•	•	•
Lavado automático	Auto Wash	•	•	•	•
Iluminación exterior de funcionamiento	Exterior operating light	•	•	•	•
Puerta deslizante	Sliding door	•	•	•	•
Portavasos con protector de silicona	Cup holder with silicone protector	•	•	-	-
NÚMERO DE PROGRAMAS DE LAVADO	NUMBER OF WASHING PROGRAMS	8	8	7	7
Intensivo	Intensive	-	-	•	•
Normal - Universal	Normal - Universal	•	•	•	•
Eco	Eco	•	•	•	•
Cristalería	Glass	•	•	•	•
58 min.	58 min.	•	•	-	-
90 min.	90 min.	-	-	•	•
Rápido	Quick	•	•	•	•
Auto	Auto	•	•	•	•
Higiene	Hygiene	•	•	-	-
Auto-Limpieza	Self cleaning	•	•	-	-
FUNCIONES	FUNCTIONS				
Función secado extra	Extra drying function	•	•	•	•
Natural Dry	Natural Dry	-	-	•	•
Función de higiene adicional (lavado intenso)	Extra hygiene function (Strong wash)	•	•	•	•
Función express	Express function	•	•	-	-
Apertura automática	Auto Open	•	•	-	-
Sistema dual de lavado	Dual zone wash	•	•	•	•
CONTROLES	CONTROLS				
Tipo de control	Type of control	Electrónico / Eletronic	Electrónico / Eletronic	Electrónico / Eletronic	Electrónico / Eletronic
Panel de Control	Control panel	Touch control	Touch control	Botonera / Teclado	Botonera / Teclado
Indicadores	Indicators	LED azul	LED azul	LED azul	LED azul
Funciones del indicador	Functions of Indicator	-	-	-	-
Programas (8), Zona de lavado, Programación diferida, Funciones (4)	Programs (8), Zone wash, Delay start, Functions(4)	•	•	•	•
Códigos de error, Retraso, Tiempo restante, Temperatura de lavado	Error codes, Delay, Remaining time, Washing temperature	•	•	•	•
ESPECIFICACIÓN TÉCNICA E INTERNA	TECHNICAL & INTERNAL SPECIFICATION				
Tipo de calefactor	Type of heating element	Hidden	Hidden	Hidden	Hidden
Potencia de la resistencia (230V) W	Power of heat element (230V) W	1800W	1800W	1800W	1800W
Tipo de filtro	Filter type	E5	E5	E5	E5
Color de las cestas	Color of basket	rey	Gris / Grey	Gris / Cinza	Gris / Cinza
Brazos pulverizadores	Spray arms	2	2	2	2
Sistema de secado	Drying system	NaturalDry	NaturalDry	NaturalDry	NaturalDry
AquaStop	AquaStop	•	•	•	•
Longitud de la manguera de entrada	Inlet hose length	1500mm	1500mm	1500mm	1500mm
Longitud total de la manguera de salida	Outlet hose length	1600mm	1600mm	1600mm	1600mm
Longitud de la manguera de salida (fuera de la máquina)	Outlet hose length (Expose length outside the machine)	1400mm	1400mm	1400mm	1400mm
Puntos de anclaje antibalaceo	Anti-balancing anchor points	4	4	2	2

1(*) Acero inoxidable / Aço inoxidável

2(*) Panel de control negro + Puerta de cristal negro / Painel de controle preto + porta de cristal preto

3(*) Programas (6), Inicio de retraso, Temperatura de lavado, Códigos de error, Tiempo restante, Sal, Ayuda de enjuague bajo

Programas (6), Início retardado, Temperatura de lavagem, Códigos de erro, Tempo restante, Sal, Abrihantador baixo

Lavadoras y secadoras

Washing machines & Dryers

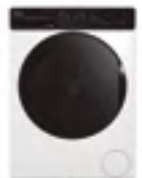

PWL-9160

PWLS-9161

PWS-8160

PWS-8161

ES	EN				
INSTALACIÓN		INSTALLATION			
Dimensiones producto - AlxAnxF (mm)	Product Dimensions - HxWxD (mm)	817 x 597 x 544	817 x 597 x 544	845 x 597 x 557	845 x 596 x 609
Medidas del Embalaje - AlxAnxF (mm)	Built-in Dimensions - HxWxD (mm)	853 x 654 x 600	853 x 654 x 600	890 x 655 x 634	881 x 641 x 638
Tensión (V AC)	Voltage (V AC)	220-240	220-240	220-240	220-240
Frecuencia (Hz)	Frequency (Hz)	50	50	50	50
Potencia de conexión (W)	Power rating (W)	2100	1850	2200	1000
Peso Neto (Kg)	Net Weight (Kg)	66,2	68,5	70	47,8
Tipo instalación	Installation type	Integración/Integrated	Integración/Integrated	Libre / Freestanding	Libre / Freestanding
Color de la máquina	Color of machine	Inox - Stainless Steel	Inox - Stainless Steel	Blanco - White	Blanco - White
Tipo de Tambor	Drum Type	Inox - Stainless Steel	Inox - Stainless Steel	Inox - Stainless Steel	Inox - Stainless Steel
Diámetro puerta (cm)	Door Diameter (cm)	47	47	51	51
Cable de alimentación (m)	Connecting Wire (m)	1,5	1,5	1,5	1,5
CARACTERÍSTICAS PRINCIPALES		MAIN FEATURES			
Capacidad Lavadora (Kg)	Washing machine capacity (Kg)	8	8	8	-
Capacidad Secadora (Kg)	Dryer Capacity (Kg)	-	5	-	8
Volumen del tambor (L)	Drum volume (L)	51	51	55	112
Consumo de agua (L) / Por lavado - Lavadora	Water Consumption (L) / Per cycle - Washing	48	48	32	-
Consumo de agua (L) / Por lavado - Lavadora/Secadora	Water Consumption (L) / Per cycle - Washing/Dry	-	37	-	-
Consumo de energía (kWh) / Ciclo - Lavadora	Energy Consumption (kWh) / Cycle - Washing	0,47	0,47	0,37	-
Consumo de energía (kWh) / Ciclo - Lavadora/Secadora	Energy Consumption (kWh) / Cycle - Washing/Dry	-	2,67	-	-
Consumo de energía (kWh) / Ciclo - Secadora	Energy Consumption (kWh) / Cycle - Dry	-	-	-	1,54
Consumo (kWh) / año	Energy Consumption (kWh) / year	47	47	47	102
Clase energética	Energy Efficiency Class	A	A	A-20%	C
Eficiencia de secado	Drying Efficiency	-	E	-	B
Nivel sonoro (dB) - Lavadora	Noise Level (dB) - Washing	46	53	64	-
Nivel sonoro (dB) - Secadora	Noise Level (dB) - Dry	-	64	-	64
Centrifugado (rpm)	Centrifuged (rpm)	1400	1400	1400	-
Tipo de secado	Drying type	-	Bomba de calor/Heat pump	-	Bomba de calor/Heat pump
NÚMERO DE PROGRAMAS DE LAVADO		NÚMERO DE PROGRAMAS DE LAVADO		NÚMERO DE PROGRAMAS DE LAVADO	
Eco 40-60		Eco 40-60		Eco 40-60	
Algodón	Cotton	•	•	•	•
Algodón ecológico	Ecological cotton	-	-	-	•
Algodón 20°C	Cotton 20°C	•	•	•	-
Algodón prelavado	Cotton prewash	•	-	•	-
Algodón Extra seco	Extra dry cotton	-	-	-	•
Sintético	Synthetics	•	•	•	•
Sintético planchado en seco	Synthetic dry ironed	•	•	•	•
Colores	Colours	•	-	•	-
Mezclado	Mix	•	-	-	•
Lana y Seda	Wool & Silk	-	•	-	-
Lana	Wool	•	-	•	•
Edredón	Duvet	-	•	•	-
Tejanos	Jeans	-	-	•	-
Toallas	Towels	-	-	-	•
Aclarado	Rinse	•	•	•	-
Pure Care	Pure Care	•	•	•	•
Higiénico	Hygienic	-	-	-	•
Centrifugado/Drenaje	Spin/Drain	•	•	•	-
Rápido 12 min	Rapid 12 min	-	-	•	-
Rápido 15 min	Rapid 15 min	•	•	-	-
Rápido 34 min	Rapid 34 min	-	-	-	•
Rápido 60' 60°C	Fast 60' 60°C	•	•	•	•
Secado suave - delicado	Gentle drying - delicate	-	•	-	•
Secado algodón	Cotton Dry	-	•	-	•
Lavado y Secado rápido	Quick Wash & Dry	-	•	-	-
Lavado y Secado algodón	Cotton Wash & Dry	-	-	-	-
Lavado a mano/Delicado	Hand wash/Delicate	•	-	•	-
Antiarrugas	Anti-crease	-	-	-	•
FUNCIONES ADICIONALES		EXTRAS FUNCTIONS			
Tres niveles de secado	Three levels of drying	-	•	-	-
Secados 10/30/60/90/120/150 min	Drying times 10/30/60/90/120/150 min.	-	• (except 10 & 150 min)	-	•
Ajuste de temperatura	Temperature setting	•	•	•	-
Velocidad de centrifugado	Spin speed setting	•	•	•	-
Ajuste del tiempo de retardo	Delay time setting	-	•	•	-
Prelavado	Prewash	•	-	•	-
Lavado rápido	Rapid wash	•	-	•	-
Planchado fácil	Easy ironing	•	-	•	-
Aclarado extra	Extra rinse	•	-	•	-
Antialérgico	Anti Allergic	•	-	•	-
Ajuste del nivel de manchas	Stain level setting	•	-	-	-
Tiempo de retardo	Delay time setting	•	-	-	-
Quitar manchas	Stain remove	•	-	•	-
Cuidado Vapor	Steam Care	-	-	•	-
Ecológico	Eco-logic	-	-	•	-
CONTROLES		CONTROLS			
Tipo de control	Type of control	electrónico / Electronic	Electrónico / Electronic	Electrónico / Electronic	Electrónico / Electronic
Indicadores	Indicators	LED azul	LED azul	LED azul	LED azul
Detección de fallos	Failure detection	•	•	•	•
Bloqueo para niños	Child lock	•	•	•	•
Indicador de bloqueo de puerta	Door lock indicator	-	•	•	-
Indicador de corte de agua	Cut of water indicator	-	•	•	-
Protección contra desbordamiento	Overflow protection	•	•	•	-
Lavado a vapor	Steam wash	•	-	•	-
Indicador filtro lleno	Filter full indicator	-	•	•	•

Frigoríficos Refrigerators



Código / Code	PFBE CONG	PFBI COMBI	PFBI FRIGO	PFBI CONG	PFBI L COMBI
	010665	010334 / 010335	010336	010337	010523

ES

EN

INSTALACIÓN	INSTALLATION					
Acabado	Finished	Integrable	Integrable	Integrable	Integrable	Integrable
Dimensiones Producto (HxWxD) mm	Product Dimensions (HxWxD) mm	820x596x550	1770x540x545	1770x540x545	1770x540x545	1937x550x540
Dimensiones con embalaje HxWxD (mm)	Dimensions with packaging (HxWxD)	880x640x580	1834x584x577	1834x584x577	1834x584x577	2000x573x583
Voltaje (V~AC)	Voltage (V~AC)	220-240	220-240	220-240	220-240	220-240
Frecuencia (Hz)	Frequency (Hz)	50	50	50	50	50
Corriente (A)	Current (A)	0,8	0,85	0,5	1,16	0,8
Descongelación-Termo- stato (W)	Defrost Heater (W)	160	153	-	207	160
Cable de alimentación (m)	Connecting Wire (m)	1,5	1,8	1,8	1,8	1,8
Peso Neto / Bruto (Kg)	Net / Gross weight (Kg)	31,5 / 34,5	53 / 56,5	41,5 / 53	56 / 60	62 / 67,5
CARACTERÍSTICAS	FEATURES					
Volumen Total (l)	Total Volume (l)	83	242	294,4	196,6	267
Volumen Frigorífico (l)	Refrigerator volume (l)	-	179,5	294,4	-	200
Volumen Congelador (l)	Freezer volume (l)	83	63	-	196,6	67
NO FROST	NO FROST	•	•	-	•	•
Multi Cooling	Multi Cooling	-	-	-	-	-
Libre Instalación	Freestanding	-	-	-	-	-
Integración / Paneleble	Built-in	•	•	•	•	•
Clase energética	Energy Efficiency Class	D	E	E	E	E
Consumo (Kwh/ año)	Energy Consumption (kWh/year)	151	218	112	231	232
Consumo (Kw/h)	Energy Consumption (kW/h)	0,413	0,597	0,306	0,569	0,370
Emissiones de ruido acústico aéreo (dB(A) re 1 pW)	Airborne acoustical noise emissions (dB(A) re 1 pW)	38	41	39	40	41
Clasificación sonora	Noise emission class	C	C	C	C	C
Clase climática	Climate Class (Temp. Range)	ST	T / N	ST / SN	T / SN	ST
Refrigerante	Refrigerant	R600A	R600A	R600A	R600A	R600A
Volumen de refrigeración (g)	Refrigerant Mass (g)		32	33	44	
Temperatura ambiente mínima (°C)	Minimum ambient temperature (°C)	10	16	10	10	18
Temperatura ambiente máxima (°C)	Maximum ambient temperature (°C)	38	43	38	43	38
Luz	Light	-	LED	LED	LED	LED

Frigoríficos Refrigerators



Código / Code	PFBI XL COMBI 010522	PFBI XL FRIGO 010681	PFLC COMBI 010338	PFL AMER L 010717 IX / 010716 CR	PFLC AMER XL 010718
---------------	-------------------------	-------------------------	----------------------	-------------------------------------	------------------------

ES

EN

INSTALACIÓN	INSTALLATION					
Acabado	Finished	Integrable	Integrable	Cristal Negro	Cristal Negro / Inox	Cristal Negro
Dimensiones Producto (HxWxD) mm	Product Dimensions (HxWxD) mm	1937x690x550	1937x690x550	2010x595x660	1905x910x600	1905x910x690
Dimensiones con embalaje HxWxD (mm)	Dimensions with packaging (HxWxD)	2000x730x583	2000x730x583	206x664x728	1993x972x634	1993x972x725
Voltaje (V~AC)	Voltage (V~AC)	220-240	220-240	220-240	220-240	220-240
Frecuencia (Hz)	Frequency (Hz)	50	50	50	50	50
Corriente (A)	Current (A)	0,8	1,8	1,1	1,5	1,5
Descongelación-Termo- stato (W)	Defrost Heater (W)	180	180	145	164	164
Cable de alimentación (m)	Connecting Wire (m)	1,8	1,9	1,8	1,8	1,8
Peso Neto / Bruto (Kg)	Net / Gross weight (Kg)	80,5 / 86,5	83,5 / 89,5	94 / 100		96 / 106
CARACTERÍSTICAS	FEATURES					
Volumen Total (l)	Total Volume (l)	341	337	366	505	600
Volumen Frigorífico (l)	Refrigerator volume (l)	257	337	266,1	349	429
Volumen Congelador (l)	Freezer volume (l)	84	-	100,6	156	171
NO FROST	NO FROST	•	•	•	•	•
Multi Cooling	Multi Cooling	-	-	-	-	-
Libre Instalación	Freestanding	-	-	•	•	•
Integración / Paneleble	Built-in	•	•	-	-	-
Clase energética	Energy Efficiency Class	E	E	C	D	E
Consumo (Kwh/ año)	Energy Consumption (kWh/year)	250	165	160	249	316
Consumo (Kw/h)	Energy Consumption (kWh)	0,420	0,200	0,438	0,682	0,870
Emissiones de ruido acústico aéreo (dB(A) re 1 pW)	Airborne acoustical noise emissions (dB(A) re 1 pW)	41	39	36	39	39
Clasificación sonora	Noise emission class	C	C	C	C	C
Clase climática	Climate Class (Temp. Range)	ST	ST	T / SN	ST	ST
Refrigerante	Refrigerant	R600A	R600A	R600A	R600A	R600A
Volumen de refrigeración (g)	Refrigerant Mass (g)			55	68	68
Temperatura ambiente mínima (°C)	Minimum ambient temperature (°C)	18	18	10		
Temperatura ambiente máxima (°C)	Maximum ambient temperature (°C)	38	38	43		
Luz	Light	LED	LED	LED	LED	LED



PVZB
15-9

PVMB
30-16

PVMB
40-28

PVMBP HD
40-25

PVMB
60-46

PVMBP
60-44

ES

EN

INSTALACIÓN	INSTALLATION						
Dimensiones producto (mm) HxWxD (mm) SIN tirador	Product Dimensions (HxWxD mm)	825x150x525	820x295x575	820x395x575	880x395x555	820x595x575	820x595x555
Dimensiones encastre (HxWxD mm)	Built-in Dimensions (HxWxD mm)	>830 x 156 x >550	822x300x ≥575	822x400x ≥575	882x400x ≥555	822x600x ≥575	822x600x ≥555
Tensión (V AC)	Voltage (V AC)	220-240V~	220-240V~	220-240V~	220-240V~	220-240V~	220-240V~
Frecuencia (Hz)	Frequency (Hz)	50	50	50	50	50	50
Potencia (W)	Power Input (W)	55	100	100	100	100	100
Peso Neto (Kg)	Net Weight (Kg)	20	28	36	39	47	47
Profundidad sin tirador_D (mm)	Depth without handle (mm)	525	575	575	55	575	555
Profundidad con tirador (mm)	Depth with handle (mm)	565	615	615	-	615	-
Profundidad cuerpo sin puerta (mm)	Body depth without door (mm)	475	530	530	510	530	510
Dimensiones zócalo (mm)	Dimensions base_DxH (mm)	100x95	72x95	72x95	72x95	72x95	72x95
Cable de alimentación (m)	Connecting wire (m)	1,6	1,8	1,8	1,8	1,8	1,8
Formato libre instalación	Free Standing	•	•	•	•	•	•
Integración en mueble	Built-in	-	-	-	-	-	-
Integración bajo mueble	Built-under	•	•	•	•	•	•
CARACTERÍSTICAS	FEATURES						
Secciones de frío	Temperature zones	1	2	2	2	2	2
Aislamiento secciones frío	Isolation of temperature zones	•	•	•	•	•	•
Nº Bandejas madera Haya	Removable trays (Haya wood)	6	5	4	5	5	4
Nº Bandejas departamento fijo	Number Fixed trays	3	1	1	1	1	1
Nº bandejas o guías fijas	Cabinet Shelf or Sliding Shelves	-	5	4	5	5	4
Bandejas con guías correderas	Trays with sliding guides	-	-	-	5	5	4
Control temperatura	Temp. Control	Electronic-Digital	Electronic-Digital	Electronic-Digital	Electronic-Digital	Electronic-Digital	Electronic-Digital
Temperatura operativa	Operating Range (°C/°F)	5~20°C	5~20°C	5~20°C	5~20°C	5~20°C	5~20°C
Defrost (Descongelado)	Defrosting	•	•	•	•	•	•
Control de humedad (Caja humedad)	Humidity Control (Humidity Box)	-	•	•	•	•	•
Calefactor	Heating function	-	•	•	•	•	•
Alarma temperatura	Temperature Alarm System	-	•	•	•	•	•
Alarma puerta abierta	Door open alert system	-	•	•	•	•	•
Filtro olores	Deodorizer - Active Charcoal Filter	-	•	•	•	•	•
Depósito control humedad interior.	Wine Storage Compartment Humidity	-	•	•	•	•	•
Sistema auto. con bomba de control de humedad.	Control System Humidity Pump for humidity control	-	-	-	-	-	-
Indicador temp. display en °C/°F	°C/°F Temperature Display	•	•	•	•	•	•
Color display and interior	Display Color	Azul o Blanco / Blue or White	Multicolor/ Multicolour	Multicolor/ Multicolour	Multicolor/ Multicolour	Multicolor/ Multicolour	Multicolor/ Multicolour
Luz interior	Interior Light Type (LED/Bulb)	LED	LED	LED	LED	LED	LED
Interruptor luz	Light Switch	•	•	•	•	•	•
BISAGRA profesional integrada	Fully-integrated professional hinge	-	-	-	•	-	•
Puerta reversible	Door reversibility	-	•	•	•	•	•
Ángulo apertura	Door Opening Angle	165°	115°	115°	95-115°	115°	95-115°
Cristal puerta Filtro UV	Anti UV Glass	•	•	•	•	•	•
Nº cristales puerta	Num. of Layers for Glass Door	3	3	3	3	3	3
Cristal templado	Tempered Glass	•	•	•	•	•	•
Sistema ventilación integrado	Integrated ventilation system	-	-	-	-	-	-
Ventilación, frontal zócalo	Ventilation Front Plinth	•	•	•	•	•	•
Ventilación, frontal integrada	Air Ventilation Front integrated	-	-	-	-	-	-
Capacidad, Volumen almacenamiento (l)	Total Storage Volume (l)	22	52	75	80	125	116
Clase energética	Energy Efficiency Class	G	F	F	F	F	F
Clase climática	Climate Class	ST	ST	ST	ST	ST	ST
Corriente (A)	Current (A)	0,4	1,2	1,2	1,2	1,2	1,2
Consumo (Kwh/ año)	Energy Consumption (kWh/y.r)	106	98	100	100	104	104
INVERTER (Sí / NO)	INVERTER (Yes / No)	-	•	•	•	•	•
Refrigerante	Refrigerant Type	R600a	R600a	R600a	R600a	R600a	R600a
Potencia sonora LwA (dBA)	Sound level LwA (dB(A))	38	35	35	35	35	35



PVMBP HD 60-52



PVMC 15-5



PVMAV- P / PA
45-16



PVMAV- P / PA
60-23



PVMAV- P / PA
88-45

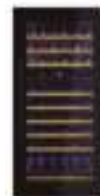

PVMAV- P / PA
124-65

ES

EN

INSTALACIÓN	INSTALLATION						
Dimensiones producto (mm) HxWxD (mm) SIN tirador	Product Dimensions (HxWxD mm)	880x595x555	141X595X557	455x595x559	595x595x559	885x595x559	1234x595x559
Dimensiones encastre (HxWxD mm)	Built-in Dimensions (HxWxD mm)	882x600x ≥555	555X540X150	450x556x545	589x556x545	874x556x545	1223x556x545
Tensión (V AC)	Voltage (V AC)	220-240V~	220-240V~	220-240V~	220-240V~	220-240V~	220-240V~
Frecuencia (Hz)	Frequency (Hz)	50	50	50	50	50	50
Potencia (W)	Power Input (W)	100	130	100	100	100	160
Peso Neto (Kg)	Net Weight (Kg)	47	16,5	31	39	52	66
Profundidad sin tirador_D (mm)	Depth without handle (mm)	555	557	559	559	559	559
Profundidad con tirador (mm)	Depth with handle (mm)	-	-	599	599	599	599
Profundidad cuerpo sin puerta (mm)	Body depth without door (mm)	510	553	512	512	512	512
Dimensiones zócalo (mm)	Dimensions base_DxH (mm)	72x95	-	-	-	-	-
Cable de alimentación (m)	Connecting wire (m)	1,8	1,8	1,8	1,8	1,8	1,8
Formato libre instalación	Free Standing	•	-	-	-	-	-
Integración en mueble	Built-in	-	•	•	•	•	•
Integración bajo mueble	Built-under	•	•	-	-	-	-
CARACTERÍSTICAS	FEATURES						
Secciones de frío	Temperature zones	2	1	1	2	2	2
Aislamiento secciones frío	Isolation of temperature zones	•	•	•	•	•	•
Nº Bandejas madera Haya	Removable trays (Haya wood)	5	-	2	3	5	9
Nº Bandejas departamento fijo	Number Fixed trays	1	1	1	1	1	1
Nº bandejas o guías fijas	Cabinet Shelf or Sliding Shelves	5	-	2	3	4	8
Bandejas con guías correderas	Trays with sliding guides	5	-	2	3	4	8
Control temperatura	Temp. Control	Electronic-Digital	Electronic-Digital	Electronic-Digital	Electronic-Digital	Electronic-Digital	Electronic-Digital
Temperatura operativa	Operating Range (°C/°F)	5~20°C	5~20°C	5~20°C	5~20°C	5~20°C	5~20°C
Defrost (Descongelado)	Defrosting	•	•	•	•	•	•
Control de humedad (Caja humedad)	Humidity Control (Humidity Box)	•	•	•	•	•	•
Calefactor	Heating function	•	-	•	•	•	•
Alarma temperatura	Temperature Alarm System	•	•	•	•	•	•
Alarma puerta abierta	Door open alert system	•	•	•	•	•	•
Filtro olores	Deodorizer - Active Charcoal Filter	•	-	•	•	•	•
Depósito control humedad interior.	Wine Storage Compartment Humidity	•	-	•	•	•	•
Sistema auto. con bomba de control de humedad.	Control System Humidity Pump for humidity control	-	-	-	-	-	-
Indicador temp. display en °C/°F	°C/°F Temperature Display	•	•	•	•	•	•
Color display and interior	Display Color	Multicolor/ Multicolour	Multicolor/ Multicolour	Multicolor/ Multicolour	Multicolor/ Multicolour	Multicolor/ Multicolour	Multicolor/ Multicolour
Luz interior	Interior Light Type (LED/Bulb)	LED	LED	LED	LED	LED	LED
Interruptor luz	Light Switch	•	•	•	•	•	•
BISAGRA profesional integrada	Fully-integrated professional hinge	•	-	•	•	•	•
Puerta reversible	Door reversibility	•	-	•	•	•	•
Ángulo apertura	Door Opening Angle	95-115°	-	95-115°	95-115°	95-115°	95-115°
Cristal puerta Filtro UV	Anti UV Glass	•	•	•	•	•	•
Nº cristales puerta	Num. of Layers for Glass Door	3	3	3	3	3	3
Cristal templado	Tempered Glass	•	•	•	•	•	•
Sistema ventilación integrado	Integrated ventilation system	-	-	•	•	•	•
Ventilación, frontal zócalo	Ventilation Front Plinth	•	-	-	-	-	-
Ventilación, frontal integrada	Air Ventilation Front integrated	-	-	•	•	•	•
Capacidad, Volumen almacenamiento (l)	Total Storage Volume (l)	130	13	46	63	116	182
Clase energética	Energy Efficiency Class	F	F	E	F	G	G
Clase climática	Climate Class	ST	ST	ST	ST	ST	ST
Corriente (A)	Current (A)	1,2	0,8	1,2	1,2	1,2	1,2
Consumo (Kwh/ año)	Energy Consumption (kWh/y.r)	105	88	77	99	128	151
INVERTER (Sí / NO)	INVERTER (Yes / No)	•	•	•	•	•	•
Refrigerante	Refrigerant Type	R600a	R600a	R600a	R600a	R600a	R600a
Potencia sonora LwA (dBA)	Sound level LwA (dB(A))	35	35	35	35	36	36



PVMAV P / PA
178-101

PVZB 180-110

PVZL 180-165

PBE 89-66

PBE 182-190

ES

EN

INSTALACIÓN	INSTALLATION					
Dimensiones producto (mm) HxWxD (mm) SIN tirador	Product Dimensions (HxWxD mm)	1784x595x559	1792x595x550	1805x595x700	890x595x575	1820x595x575
Dimensiones encastre (HxWxD mm)	Built-in Dimensions (HxWxD mm)	1773x556x545	1876x645x620	1810x600x610	822x600x ≥585	1825x600x ≥585
Tensión (V AC)	Voltage (V AC)	220-240V~	220-240V~	220-240V~	220-240V~	220-240V~
Frecuencia (Hz)	Frequency (Hz)	50	50	50	50	50
Potencia (W)	Power Input (W)	160	155	120	100	160
Peso Neto (Kg)	Net Weight (Kg)	90	92	114	52	90
Profundidad sin tirador_D (mm)	Depth without handle (mm)	559	550	700	575	575
Profundidad con tirador (mm)	Depth with handle (mm)	599	590	740	615	615
Profundidad cuerpo sin puerta (mm)	Body depth without door (mm)	512	500	649	530	530
Dimensiones zócalo (mm)	Dimensions base_DxH (mm)	-	-	-	72x95	72x95
Cable de alimentación (m)	Connecting wire (m)	1,8	1,8	1,8	1,8	1,8
Formato libre instalación	Free Standing	-	•	•	•	•
Integración en mueble	Built-in	•	•	•	-	-
Integración bajo mueble	Built-under	-	-	-	•	•
CARACTERÍSTICAS	FEATURES					
Secciones de frío	Temperature zones	2	2	2	1	1
Aislamiento secciones frío	Isolation of temperature zones	•	•	•	•	-
Nº Bandejas madera Haya	Removable trays (Haya wood)	15	14	15	2	4
Nº Bandejas departamento fijo	Number Fixed trays	1	-	-	-	-
Nº bandejas o guías fijas	Cabinet Shelf or Sliding Shelves	14	14	15	-	-
Bandejas con guías correderas	Trays with sliding guides	14	14	15	-	-
Control temperatura	Temp. Control	Electronic-Digital	Electronic-Digital	Electronic-Digital	Electronic-Digital	Electronic-Digital
Temperatura operativa	Operating Range (°C/°F)	5~20°C	5~20°C	5~20°C	5~20°C	5~20°C
Defrost (Descongelado)	Defrosting	•	•	•	•	•
Control de humedad (Caja humedad)	Humidity Control (Humidity Box)	•	-	-	•	•
Calefactor	Heating function	•	-	-	•	•
Alarma temperatura	Temperature Alarm System	•	•	•	•	•
Alarma puerta abierta	Door open alert system	•	•	•	•	•
Filtro olores	Deodorizer - Active Charcoal Filter	•	•	•	•	•
Depósito control humedad interior.	Wine Storage Compartment Humidity	•	-	-	•	•
Sistema auto. con bomba de control de humedad.	Control System Humidity Pump for humidity control	-	-	-	•	•
Indicador temp. display en °C/°F	°C/°F Temperature Display	•	•	•	•	•
Color display and interior	Display Color	Multicolor/ Multicolour	Azul / Blue	Azul / Blue	Multicolor/ Multicolour	Multicolor/ Multicolour
Luz interior	Interior Light Type (LED/Bulb)	LED	LED	LED	LED	LED
Interruptor luz	Light Switch	•	•	•	•	•
BISAGRA profesional integrada	Fully-integrated profesional hinge	•	-	-	-	-
Puerta reversible	Door reversibility	•	•	•	•	•
Ángulo apertura	Door Opening Angle	95-115°	95-115°	95-115°	115°	115°
Cristal puerta Filtro UV	Anti UV Glass	•	•	•	•	•
Nº cristales puerta	Num. of Layers for Glass Door	3	2	3	3	3
Cristal templado	Tempered Glass	•	•	•	•	•
Sistema ventilación integrado	Integrated ventilation system	•	-	-	-	-
Ventilación, frontal zócalo	Ventilation Front Plinth	-	•	•	•	•
Ventilación, frontal integrada	Air Ventilation Front integrated	•	-	-	-	-
Capacidad, Volumen almacenamiento (l)	Total Storage Volume (l)	285	318	400	128	335
Clase energética	Energy Efficiency Class	G	G	G	E	G
Clase climática	Climate Class	ST	ST	ST	ST	ST
Corriente (A)	Current (A)	1,4	1,1	0,5	1,2	1,4
Consumo (Kwh/ año)	Energy Consumption (kWh/y.r)	185	151	173	76	144
INVERTER (Sí / NO)	INVERTER (Yes / No)	•	•	•	-	-
Refrigerante	Refrigerant Type	R600a	R600a	R600a	R600a	R600a
Potencia sonora LwA (dBA)	Sound level LwA (dB(A))	36	38	44	40	41

Drink Cooling Center



PFMB 60

PFMBP 60
PUSH TO OPEN

ES

EN

INSTALACIÓN	INSTALLATION		
Dimensiones_HxWxD (mm) SIN tirador	product size (HxWxD)	815x595x556	815x595x556
Encastre_HxWxD (mm)	Adjustment measures_HxWxD (mm)	822x600x ≥575	822x600x ≥575
Capacidad, Volumen almacenamiento (l)	Total Storage Volume (l)	125	125
Voltage (V AC)	Tensión (V AC)	220-240V~	220-240V~
Frequency (Hz)	Frecuencia (Hz)	50	50
Potencia (W)	Power Input (W)	100	100
Peso Neto (Kg)	Net Weight (Kg)	47	47
Profundidad sin tirador_D (mm)	Depth without handle (mm/Inches)	556	556
Profundidad con tirador (mm)	Depth with handle (mm/Inches)	596	596
Profundidad y altura zócalo_DxH (mm)	Depth and height base_DxH (mm)	72x95	72x95
Secciones de frío	Number of Sections	1	1
Nº Bandejas madera Haya	No. Trays removable wood Haya	3	3
Nº Bandejas departamento fijo	No. Trays fixed department	1	1
Nº bandejas o guías fijas	Cabinet Shelf (Q'ty) (Sliding Wooden Shelves)	1	1
Bandejas con guías correderas	Trays with sliding guides	3	3
Control temperatura	Temp. Control (Electronic-Digital/Mechanical)	Electrónico-Digital	Electrónico-Digital
Temperatura operativa	Temp. Range (°C/°F)	2~12°C	2~12°C
Defrost (Descongelado) Automático	Defrosting (Automatic)	•	•
Luz interior	Light	•	•
Alarma temperatura	Temperature Alarm System	•	•
Alarma puerta	Door Alarm System	•	•
Indicador temperatura display en °C/°F	°C/°F Temperature Display	•	•
Color Display interior	Interior Color Display	Multicolor/Multicolour	Multicolor/Multicolour
Luz interior	Interior Light Type	LED	LED
Color iluminación interior	Interior Light Color	Multicolor/Multicolour	Multicolor/Multicolour
Interruptor luz	Light Switch	•	•
BISAGRA profesional completamente integrada	Professional Fully-integrated HINDGE	-	•
Puerta reversible	Door reversibility	•	•
Ángulo apertura	Door Opening Angle	115°	95-115°
Cristal puerta Filtro UV	Anti UV Glass	•	•
Nº cristales puerta	Number of Layers for Glass Door	3	3
Cristal templado	Tempered Glass	•	•
Formato libre instalación.	Free Standing	•	•
Formato integración bajo mueble.	Built-under	•	•
Ventilación, zócalo	Air Ventilation (Kitchen Unit Ventilation/Front Plinth Ventilation)	•	•
Clase energética / 2021	Energy Efficiency Class / 2021	C	C
Clase climática	Climate Class (Temp. Range)	0,1,2,3,4,6,8	0,1,2,3,4,6,8
Corriente (A)	Current (A)	1,2	1,2
Consumo (Kwh/ año) / 2021	Energy Consumption (kWh/y.r) / 2021	255	255
Nº Unidades de lámpara led interior	Interior Light Number Qty	18	18
Consumo por unidad led interior (W)	Consumption for indoor led unit (W)	0,05	0,05
Consumo Total luz led interior (W)	Consumption Total indoor led light (W)	0,9	0,9
Refrigerante	Refrigerant Type	R600a	R600a
Potencia sonora LwA (dBA) / 2021	Sound LwA (dB(A) re 1 pW) / 2021	40	40

ADVERTENCIAS / NOTAS

- Pando se reserva el derecho de cambiar o anular cualquier medida de los artículos del catálogo, sin previo aviso y no se hace responsable de los errores u omisiones que pudieran darse en el catálogo o en esta tarifa. Características técnicas y precios de referencia válidos salvo error tipográfico u omisión.
- La configuración de la zona inferior de las campanas, en cuanto a filtros e iluminación puede variar según la imagen del catálogo, dependiendo el modelo y medida de la misma, con la finalidad de optimizar el rendimiento del producto en función de los elementos de cocción que tengan previsto instalar. Para ello nuestro departamento técnico está a su servicio para asesorarle.
- Debe tenerse en cuenta también, tanto en los motores exteriores como en los motores de tejado y mural, la necesidad de facilitar la accesibilidad al motor en caso de reparación o mantenimiento, ya sea en falsos techos dejando registro, en muros, en tejados o en chimeneas debe de preverse un acceso seguro para el personal técnico. Pando no podrá responsabilizarse de la reparación de este componente, si no se tiene en cuenta lo prescrito para estos motores.

NOTAS FINALES IBERIA

- Precios válidos hasta nuevo aviso. LOS PRECIOS NO INCLUYEN EL RESPECTIVO IMPUESTO.
- NO SE ADMITEN DEVOLUCIONES que no hayan sido autorizadas por Pando directamente y deberán ir acompañadas del número de albarán con el que fueron entregadas y con el número de factura correspondiente, si ya obra en su poder.
- VERIFIQUEN EL MATERIAL A SU ENTREGA. Sólo se dispone de 24h. para reclamar los posibles daños ocasionados por el transporte a la compañía aseguradora. Pando se reserva el derecho a verificar toda devolución y generar factura de cargo en caso de una deficiente manipulación del material.
- Los productos Pando disponen de garantía, siempre y cuando los mismos estén debidamente manipulados e instalados por personal especializado. Sólo se aceptará la devolución de material en su empaque original.
- Portes de envío incluidos para Península Ibérica, Baleares y Canarias. Para ventas inferiores a 300€ PVR, los portes serán debidos. Los portes del envío se incluirán en la factura.
- En el caso de recambios, se cobrarán los portes en la factura.

- Pando dispone de una amplia red de servicio Post Venta en todos los países donde distribuye sus productos que garantiza su calidad en el mantenimiento, servicio de repuestos y accesorios originales Pando. Para más información consulte nuestra web.
- También disponemos de una División Técnica en la Central de Pando, que atenderá sus consultas técnicas y solicitudes de servicio técnico, garantizando la mejor atención personalizada

COMMENTS / NOTES

- Pando reserves its right (without any prior notice) to change or cancel any size of catalogue items and is not responsible for errors or omissions arising thereby. Technical characteristics and reference prices are valid except for typographical errors and omissions.
- The configuration of the filters and lighting of the hood can vary from the catalogue illustration, depending on the model and size of the hood. This is to maximise the performance of the product and is dependent on the layout of the cooking elements. Our technical department will gladly offer you advice on how to do this.
- It is important to remember the requirement to ensure easy access to the motor in case of need for repair or maintenance, whether in false ceilings, walls, roofs or fireplaces, to ensure a secure access for the technical personnel of Pando. Pando shall not be responsible to repair these motors where the installation instructions of Pando were not followed.

FINAL NOTES IBERIA

- Prices are available until further notice. PRICES DON'T INCLUDE THE RESPECTIVE TAXES.
- RETURNS that have not been authorised directly by PANDO WILL NOT BE ACCEPTED and must be supported by the delivery note number with which they were delivered, and with the corresponding invoice number if it has already been received by the customer.
- CHECK THE MATERIAL AT THE TIME OF DELIVERY. You only have 24 hours to claim any damage caused by the transport to the insurance company. Pando reserves the right to check all returns and to generate a charge invoice in case of poor handling of the material.
- Pando products are guaranteed, provided that they have been properly handled and installed by specialised personnel. We will only accept the return of material in its original packaging.
- Shipping charges are included for the Iberian Peninsula, Balearic, and Canary Islands. For sales of less than 300€ PVR, shipping costs will be charged. Postage will be included in the invoice.
- In the case of replacement parts, postage will be charged to the invoice.

- Pando has an extensive after-sales service network in all the countries where it distributes the products, which guarantees the quality of maintenance, service, original Pando spare parts, and accessories. For more information, please visit our website.
- We also have a Technical Division at Pando Headquarters, which will attend to your technical requests and questions, guaranteeing the best personalised attention.

Datos de contacto Servicio Técnico Oficial Autorizado Pando / Official Pando Customer Service Contact Details

ESPAÑA, PORTUGAL Y ANDORRA:		OTROS PAÍSES:	
ES www.pando.es/asistencia-tecnica/		EN https://www.pando.es/en/after-sales-services/	
		FR https://www.pando.es/fr/service-apres-vente/	

Las imágenes y contenido de este catálogo son propiedad exclusiva de Pando - INOXPAN, S.L., por lo que queda totalmente prohibida su utilización y la reproducción total o parcial sin previa autorización por escrito.

LAS IMÁGENES MOSTRADAS EN ESTE CATÁLOGO SON INFORMATIVAS Y NO SON CONTRACTUALES.

Pando - INOXPAN, S.L. se reserva el derecho de modificar, alterar o mejorar cualquier característica, medida o dibujo técnico que se exponen en este catálogo sin previo aviso. Toda la información y precios son válidos salvo error tipográfico u omisión.

Images and content in this catalogue is of exclusive property of Pando- INOXPAN S.L, for which it is completely forbidden the use of images as well as total or partial reproduction without previous authorisation in written.

THE IMAGES SHOWN IN THIS CATALOGUE ARE FOR INFORMATION AND ARE NOT CONTRACTUAL.

Pando - INOXPAN, S.L. reserves the right to modify, alter or improve any characteristics, measurements or technical drawings shown in this catalogue without prior notice. All information and prices are valid except for typographical errors or omissions.

Pando
integral*cooking*

INXOPAN, S.L.

Pol. Ind. El Cros
Av. El Molí de les Mateves,11
Apdo. Correos nº21
08310 ARGENTONA
(Barcelona - Spain)

Tel. +34 93 757 94 11
Fax +34 93 757 96 53

España, Portugal y Andorra: com.pando@pando.es
Export: export@pando.es

www.pando.es

