



E-395
BISELADA
BEVELED



E-395 Biselada
Beveled

E-396 Sobre encimera o encastrada
Built-in or Flushed

Campana integrada en la placa de cocción. Cristal negro
Cooker Hood integrated into induction cooktop. Black glass



eco PLUS



Last TIME



Accesorio incluido
Included accessory
Rascador especial de limpieza
Special cleaning scraper



E-395
BISELADA
BEVELED



E-396
ENCASTRADA
FLUSHED

E-396

SOBRE ENCIMERA O ENCASTRADA
BUILT-IN OR FLUSHED



E-395

Biselada
Beveled

E-396

Sobre encimera o encastrada
Built-in or Flushed

Instalación fácil y compatible con
cualquier tipo de muebles
Easy and compatible with
all kind of furniture



E-395 / E-396



eco PLUS



Last TIME

Filters NANOTEC

Filters ALU

Filters Auto.

AIR Clean 24h

Filters ECO PLASMA

E-395 Cristal biselado / Beveled glass S.E.C. System® Motor Interior / Interior Motor

Motor	Ø tubo	Clas. Ener.	Ref.
Recirculación / Recirculation V.930 eco	Ø150	A+	010851

E-396 Cristal recto / Straight glass S.E.C. System® Motor Interior / Interior Motor

Motor	Ø tubo	Clas. Ener.	Ref.
Recirculación / Recirculation V.930 eco	Ø150	A+	010853

NANOTEC



ALTA EFICIENCIA, LAVABLE Y REACTIVABLE
EFFICIENCY, WASHABLE AND REACTIVABLE

Los filtros Nanotec ofrecen un excelente rendimiento en sistemas de recirculación. Gracias a su innovadora composición, pueden lavarse en lavavajillas y reactivarse en horno, prolongando su vida útil. Incorporan esferas de carbón activado con una densidad de 2200 g/m², optimizando la absorción de olores y alcanzando una eficacia del 75%. Su durabilidad supera los 3 años, dependiendo del uso y mantenimiento.

Nanotec filters offer excellent performance in recirculation systems. Thanks to their innovative composition, they can be cleaned in the dishwasher and reactivated in the oven, extending their useful life. They incorporate activated carbon spheres with a density of 2200 g/m², optimising odour absorption and achieving 75% efficiency. Their durability exceeds 3 years, depending on use and maintenance.

Características de la campana	Features of the cooker hood
Mínima altura interior de la campana 220 mm	Shallow built-under in 220 mm
Motor de bajo consumo y mayor eficiencia.	Eco-efficient low consumption motor
Bajo nivel sonoro: 52 dB min. / 72 dB max.	Lowest Noise levels Mix 52 Db / Max 72 Db
Excelente velocidad de aspiración	Excellent Airflow
Sistema de filtrado NANOTEC	NANOTEC filter system
Conducto rectangular trasero: 220 x 90 mm	Rear 220 x 90 mm rectangular ducting pipe (Extraction version)
Nueva Rejilla. Mejora de la succión	New - Suction area

Características de la placa de inducción	Features of the induction hob
Potencia Total: 7400 W	Total Power: 7400 W
Stop&Go	Stop&Go
Cristal cerámico Keraspectrum	Keraspectrum Glass and E.G.O High Tech inside
Cocción automática	Automatic cooking
La función Bridge permite acoplar 2 inductores de cada lado para hacer un único conjunto	Bridge function allows coupling 2 inductors on each side to make it a unique set
Detección inteligente de ausencia del recipiente	Smart detection of missing pot
La función Chef le permite modificar la posición de la sartén dentro de la placa sin perder la potencia de calor	Chef function. Let you easily move the pan from Inductors .left to right keeping the heating power level
Indicador de calor residual	Residual heat indicator
Función Booster y Doble Booster Acelerador de calor	Booster & Double Booster function Heating accelerator

Notas / Notes

Incluye bandeja de limpieza fácil que recoge el aceite
Includes easy-cleaning tray for collection of oils

Kits tubos salida inferior / Pipe kit for bottom outlet:

Descripción Description	Ref.
Codo + 120 cm. de tubo / Bend + 120 cm. duct	010864

Opcionales* / Options*

Sistema de filtrado ECO PLASMA
ECO PLASMA filter system

Medidas Encastre / Dimensions built in size

Instalación vidrio sobre encimera
Installation "built-in" / "built-on top"

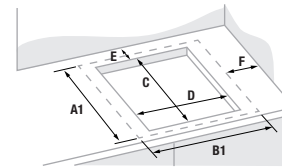

Instalación vidrio enrasado
Installation "flushed"

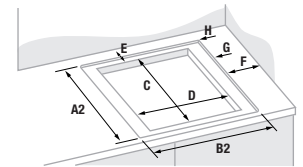

Tamaño del Vidrio Size of glass		Tamaño de Corte Size of cut		Fondo Rear	Lado Lateral	Radio Radio	Instalación en vidrio al ras Installation "flushed"		
A1	B1	C	D	E (min)	F (min)	H	A2	B2	G*
520	780	490	750	50	40	8	524	784	5

* Profundidad/Depth

La medida exterior mínima del mueble para instalar este tipo de campana es de 900 x 560 mm.

The minimal external dimension of furniture to install this hood should be 900 x 560 mm.

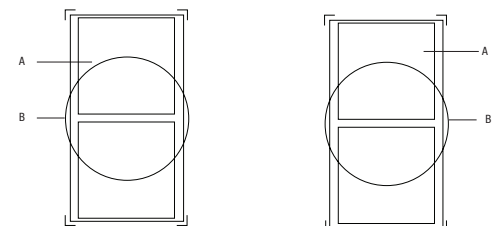

	EXT.	MÍN.	MÁX.	Power W	Booster W	Súper Booster W
A	220 x 180 mm	100 mm	Ø 180 mm	2100w	2600w	3700w
B	220 x 360 mm	135 mm	Ø 220 mm	-	-	-

E-395 / E-396

Vista frontal / Front view

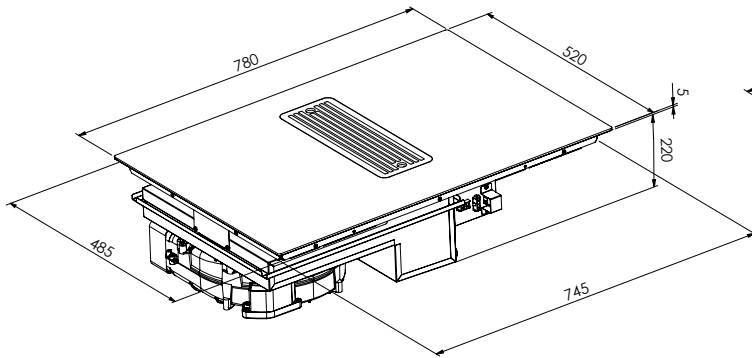

Vista trasera / Rear view

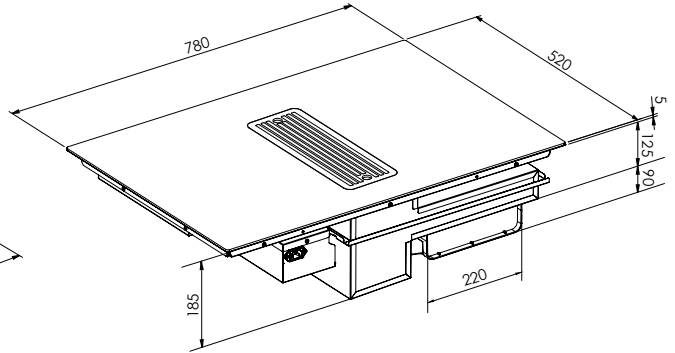

Salida trasera / Rear exit

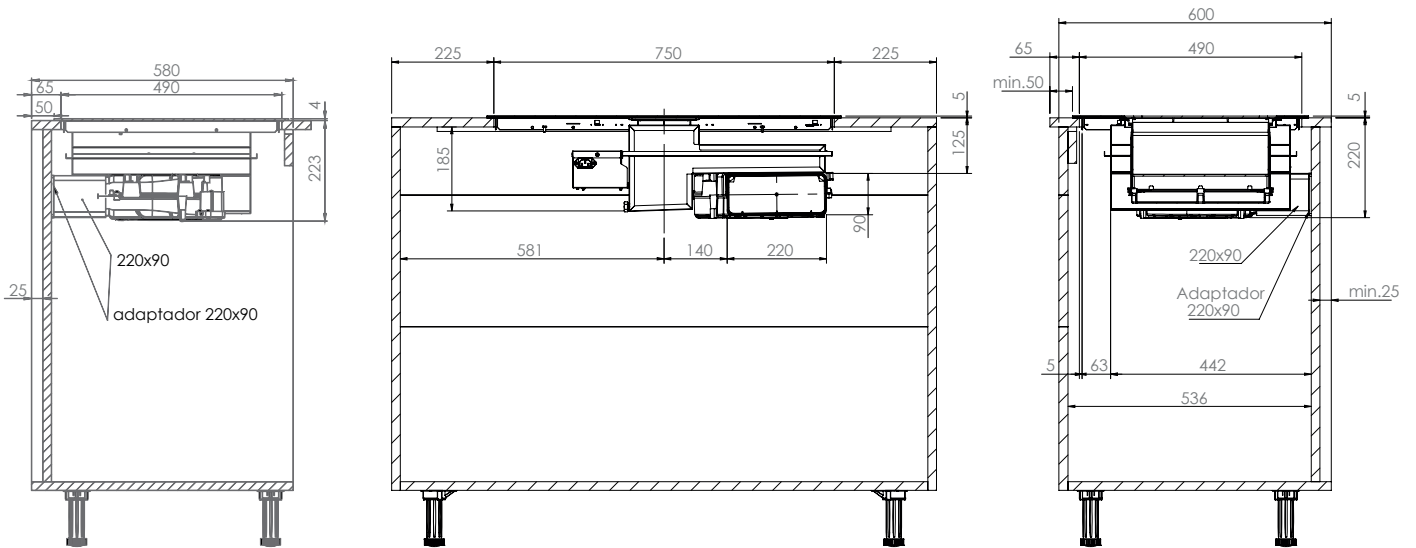

Salida inferior / Bottom outlet

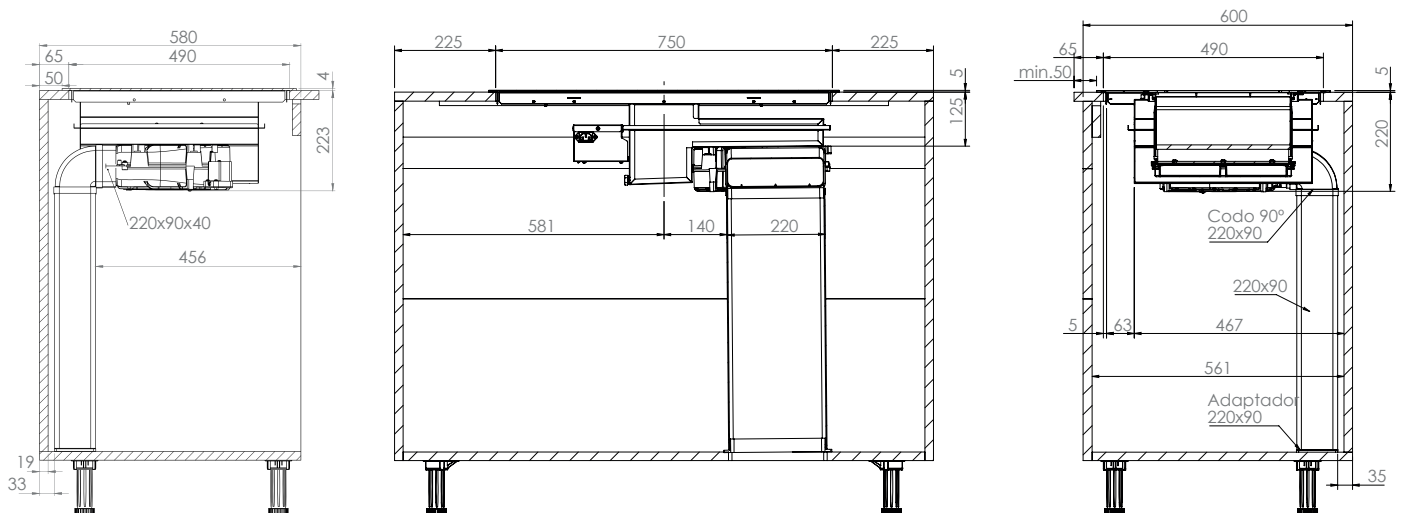

Medidas en / Dimensions in mm